

SOLUTIONS

CHAPTER 1

Exercise 1.1

(a) Biologists study cells at many levels. The cells are built from organelles such as the mitochondria, ribosomes, and chloroplasts. Organelles are built of macromolecules such as proteins, lipids, nucleic acids, and carbohydrates. These biochemical macromolecules are built simpler molecules such as carbon chains and amino acids. When studying at one of these levels of abstraction, biologists are usually interested in the levels above and below: what the structures at that level are used to build, and how the structures themselves are built.

(b) The fundamental building blocks of chemistry are electrons, protons, and neutrons (physicists are interested in how the protons and neutrons are built). These blocks combine to form atoms. Atoms combine to form molecules. For example, when chemists study molecules, they can abstract away the lower levels of detail so that they can describe the general properties of a molecule such as benzene without having to calculate the motion of the individual electrons in the molecule.

Exercise 1.3

Ben can use a hierarchy to design the house. First, he can decide how many bedrooms, bathrooms, kitchens, and other rooms he would like. He can then jump up a level of hierarchy to decide the overall layout and dimensions of the house. At the top-level of the hierarchy, he material he would like to use, what kind of roof, etc. He can then jump to an even lower level of hierarchy to decide the specific layout of each room, where he would like to place the doors, windows, etc. He can use the principle of regularity in planning the framing of the house. By using the same type of material, he can scale the framing depending on the dimensions of each room. He can also use regularity to choose the same (or a small set of) doors and windows for each room. That way, when he places

a new door or window he need not redesign the size, material, layout specifications from scratch. This is also an example of modularity: once he has designed the specifications for the windows in one room, for example, he need not re-specify them when he uses the same windows in another room. This will save him both design time and, thus, money. He could also save by buying some items (like windows) in bulk.

Exercise 1.5

(a) The hour hand can be resolved to $12 * 4 = 48$ positions, which represents $\log_2 48 = 5.58$ bits of information. (b) Knowing whether it is before or after noon adds one more bit.

Exercise 1.7

$2^{16} = 65,536$ numbers.

Exercise 1.9

(a) $2^{16}-1 = 65535$; (b) $2^{15}-1 = 32767$; (c) $2^{15}-1 = 32767$

Exercise 1.11

(a) 0; (b) $-2^{15} = -32768$; (c) $-(2^{15}-1) = -32767$

Exercise 1.13

(a) 10; (b) 54; (c) 240; (d) 6311

Exercise 1.15

(a) A; (b) 36; (c) F0; (d) 18A7

Exercise 1.17

(a) 165; (b) 59; (c) 65535; (d) 3489660928

Exercise 1.19

(a) 10100101; (b) 00111011; (c) 1111111111111111;
(d) 11010000000000000000000000000000

Exercise 1.21

(a) -6; (b) -10; (c) 112; (d) -97

Exercise 1.23

(a) -2; (b) -22; (c) 112; (d) -31

Exercise 1.25

(a) 101010; (b) 111111; (c) 11100101; (d) 1101001101

Exercise 1.27

(a) 2A; (b) 3F; (c) E5; (d) 34D

Exercise 1.29

(a) 00101010; (b) 11000001; (c) 01111100; (d) 10000000; (e) overflow

Exercise 1.31

00101010; (b) 10111111; (c) 01111100; (d) overflow; (e) overflow

Exercise 1.33

(a) 00000101; (b) 11111010

Exercise 1.35

(a) 00000101; (b) 00001010

Exercise 1.37

(a) 52; (b) 77; (c) 345; (d) 1515

Exercise 1.39

(a) 100010_2 , 22_{16} , 34_{10} ; (b) 110011_2 , 33_{16} , 51_{10} ; (c) 010101101_2 , AD_{16} , 173_{10} ; (d) 011000100111_2 , 627_{16} , 1575_{10}

Exercise 1.41

15 greater than 0, 16 less than 0; 15 greater and 15 less for sign/magnitude

Exercise 1.43

4, 8

Exercise 1.45

5,760,000

Exercise 1.47

46.566 gigabytes

Exercise 1.49

128 kbits

Exercise 1.51

----- ----- ----- ----- ----- -----						
	-2	-1	0	1	2	3
Unsigned			00	01	10	11
	10	11	00	01		
			11	00 10	01	

Two's Complement

Sign/Magnitude

Exercise 1.53

(a) 11011101; (b) 110001000 (overflows)

Exercise 1.55

(a) 11011101; (b) 110001000

Exercise 1.57

- (a) $000111 + 001101 = 010100$
- (b) $010001 + 011001 = 101010$, overflow
- (c) $100110 + 001000 = 101110$

- (d) $011111 + 110010 = 010001$
- (e) $101101 + 101010 = 010111$, overflow
- (f) $111110 + 100011 = 100001$

Exercise 1.59

- (a) 0x2A; (b) 0x9F; (c) 0xFE; (d) 0x66, overflow

Exercise 1.61

- (a) $010010 + 110100 = 000110$; (b) $011110 + 110111 = 010101$; (c) $100100 + 111101 = 100001$; (d) $110000 + 101011 = 011011$, overflow

Exercise 1.63

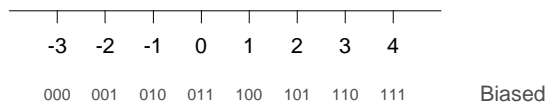

Exercise 1.65

- (a) 0011 0111 0001
- (b) 187
- (c) $95 = 1011111$
- (d) Addition of BCD numbers doesn't work directly. Also, the representation doesn't maximize the amount of information that can be stored; for example 2 BCD digits requires 8 bits and can store up to 100 values (0-99) - unsigned 8-bit binary can store 28 (256) values.

Exercise 1.67

Both of them are full of it. $42_{10} = 101010_2$, which has 3 1's in its representation.

Exercise 1.69

```
#include <stdio.h>

void main(void)
{
    char bin[80];
    int i = 0, dec = 0;

    printf("Enter binary number: ");
    scanf("%s", bin);
```

```

while (bin[i] != 0) {
    if (bin[i] == '0') dec = dec * 2;
    else if (bin[i] == '1') dec = dec * 2 + 1;
    else printf("Bad character %c in the number.\n", bin[i]);
    i = i + 1;
}
printf("The decimal equivalent is %d\n", dec);
}

```

Exercise 1.71

OR3

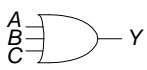

$Y = A + B + C$

A	B	C	Y
0	0	0	0
0	0	1	1
0	1	0	1
0	1	1	1
1	0	0	1
1	0	1	1
1	1	0	1
1	1	1	1

(a)

XOR3

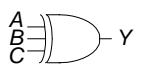

$Y = A \oplus B \oplus C$

A	B	C	Y
0	0	0	0
0	0	1	1
0	1	0	1
0	1	1	0
1	0	0	1
1	0	1	0
1	1	0	0
1	1	1	1

(b)

XNOR4

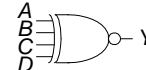

$Y = \overline{A \oplus B \oplus C \oplus D}$

A	C	B	D	Y
0	0	0	0	1
0	0	0	1	0
0	0	1	0	0
0	0	1	1	1
0	1	0	0	0
0	1	0	1	1
0	1	1	0	1
0	1	1	1	0
1	0	0	0	0
1	0	0	1	1
1	0	1	0	1
1	0	1	1	0
1	1	0	0	1
1	1	0	1	0
1	1	1	0	0
1	1	1	1	1

(c)

Exercise 1.73

A	B	C	Y
0	0	0	0
0	0	1	0
0	1	0	0
0	1	1	1
1	0	0	0
1	0	1	1
1	1	0	1
1	1	1	1

Exercise 1.75

A	B	C	Y
0	0	0	1
0	0	1	1
0	1	0	1
0	1	1	0
1	0	0	1
1	0	1	0
1	1	0	1
1	1	1	0

Exercise 1.77

$$2^{2^N}$$

Exercise 1.79

No, there is no legal set of logic levels. The slope of the transfer characteristic never is better than -1, so the system never has any gain to compensate for noise.

Exercise 1.81

The circuit functions as a buffer with logic levels $V_{IL} = 1.5$; $V_{IH} = 1.8$; $V_{OL} = 1.2$; $V_{OH} = 3.0$. It can receive inputs from LVCMOS and LVTTL gates because their output logic levels are compatible with this gate's input levels. However, it cannot drive LVCMOS or LVTTL gates because the 1.2 V_{OL} exceeds the V_{IL} of LVCMOS and LVTTL.

Exercise 1.83

(a) XOR gate; (b) $V_{IL} = 1.25$; $V_{IH} = 2$; $V_{OL} = 0$; $V_{OH} = 3$

Exercise 1.85

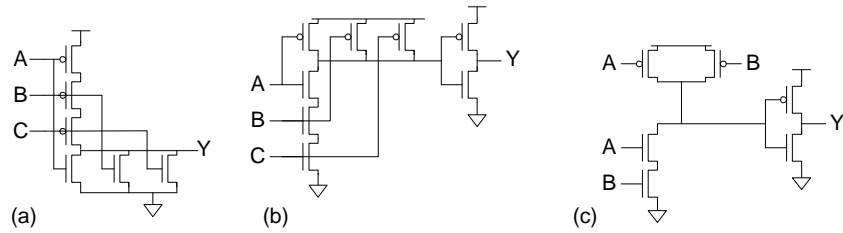

Exercise 1.87

XOR

A	B	Y
0	0	0
0	1	1
1	0	1
1	1	0

Exercise 1.89

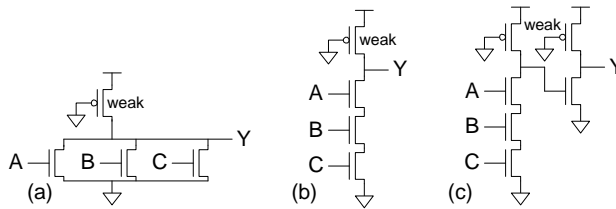

Question 1.1

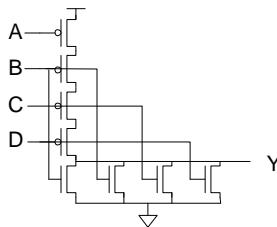

Question 1.3

17 minutes: (1) designer and freshman cross (2 minutes); (2) freshman returns (1 minute); (3) professor and TA cross (10 minutes); (4) designer returns (2 minutes); (5) designer and freshman cross (2 minutes).

CHAPTER 2

Exercise 2.1

(a) $Y = \bar{\bar{A}}\bar{B} + A\bar{B} + AB$

(b) $Y = \bar{A}\bar{\bar{B}}\bar{C} + ABC$

(c) $Y = \bar{A}\bar{B}\bar{C} + \bar{A}\bar{B}\bar{C} + \bar{A}\bar{B}\bar{C} + \bar{A}\bar{B}\bar{C} + ABC$

(d)

$$Y = \bar{\bar{A}}\bar{\bar{B}}\bar{\bar{C}}\bar{\bar{D}} + \bar{\bar{A}}\bar{\bar{B}}\bar{\bar{C}}\bar{D} + \bar{\bar{A}}\bar{\bar{B}}\bar{C}\bar{D} + \bar{\bar{A}}\bar{B}\bar{C}\bar{D} + \bar{\bar{A}}\bar{B}\bar{C}\bar{D} + \bar{\bar{A}}\bar{B}\bar{C}\bar{D} + \bar{A}\bar{B}\bar{C}\bar{D}$$

(e)

$$Y = \bar{A}\bar{B}\bar{C}\bar{D} + \bar{A}\bar{B}\bar{C}\bar{D} + \bar{A}\bar{B}\bar{C}\bar{D} + \bar{A}\bar{B}\bar{C}\bar{D} + \bar{A}\bar{B}\bar{C}\bar{D} + \bar{A}\bar{B}\bar{C}\bar{D} + \bar{A}\bar{B}\bar{C}\bar{D} + ABCD$$

Exercise 2.3

(a) $Y = (A + \bar{B})$

(b)

$$Y = (A + B + \bar{C})(A + \bar{B} + C)(A + \bar{B} + \bar{C})(\bar{A} + B + C)(\bar{A} + B + \bar{C})(\bar{A} + \bar{B} + C)$$

(c) $Y = (A + B + \bar{C})(A + \bar{B} + \bar{C})(\bar{A} + \bar{B} + C)$

(d)

$$Y = (A + \bar{B} + \bar{C} + \bar{D})(\bar{A} + \bar{B} + C + \bar{D})(\bar{A} + \bar{B} + \bar{C} + D)(\bar{A} + \bar{B} + \bar{C} + \bar{D})(\bar{A} + B + C + \bar{D})(\bar{A} + B + \bar{C} + D)(\bar{A} + B + C + D)(\bar{A} + B + \bar{C} + D)$$

(e)

$$Y = (A + B + C + \bar{D})(A + B + \bar{C} + D)(A + \bar{B} + C + D)(A + \bar{B} + \bar{C} + \bar{D})(\bar{A} + B + C + D)(\bar{A} + B + \bar{C} + D)(\bar{A} + \bar{B} + C + D)(\bar{A} + \bar{B} + \bar{C} + D)$$

Exercise 2.5

(a) $Y = A + \bar{B}$

(b) $Y = \bar{A}\bar{B}\bar{C} + ABC$

(c) $Y = \bar{A}\bar{C} + \bar{A}\bar{B} + AC$

(d) $Y = \bar{A}\bar{B} + \bar{B}\bar{D} + AC\bar{D}$

(e)

$$Y = \bar{A}\bar{B}\bar{C}\bar{D} + \bar{A}\bar{B}C\bar{D} + \bar{A}B\bar{C}\bar{D} + \bar{A}BC\bar{D} + A\bar{B}\bar{C}\bar{D} + A\bar{B}C\bar{D} + AB\bar{C}\bar{D} + ABC\bar{D}$$

This can also be expressed as:

$$Y = \overline{(A \oplus B)(C \oplus D)} + (A \oplus B)(C \oplus D)$$

Exercise 2.7

(a)

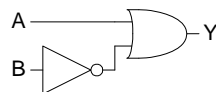

(b)

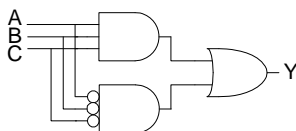

(c)

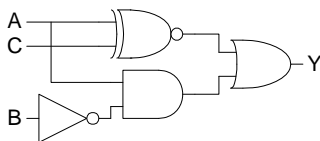

(d)

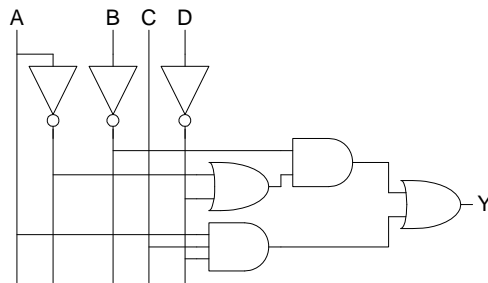

(e)

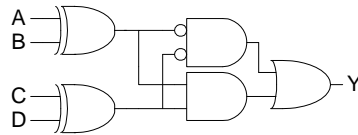

Exercise 2.9

(a) Same as 2.7(a)

(b)

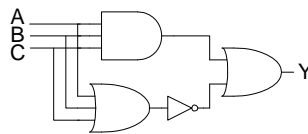

(c)

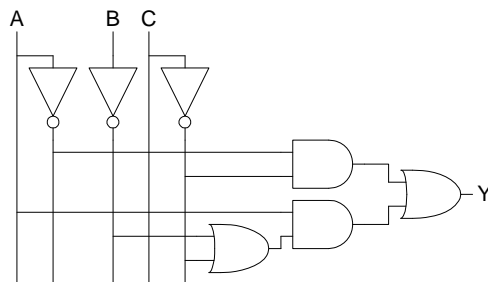

(d)

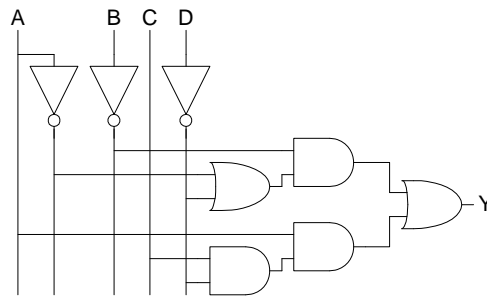

(e)

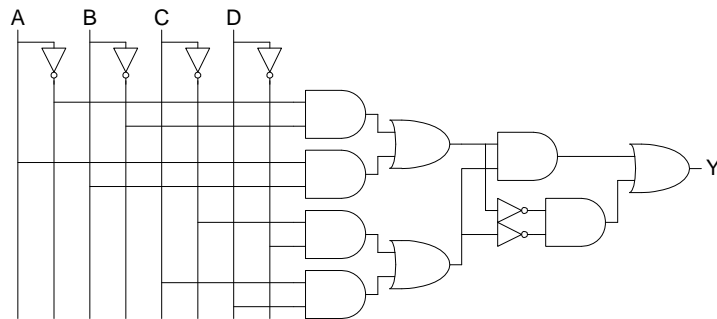

Exercise 2.11

(a)

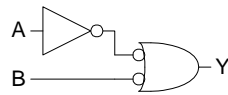

(b)

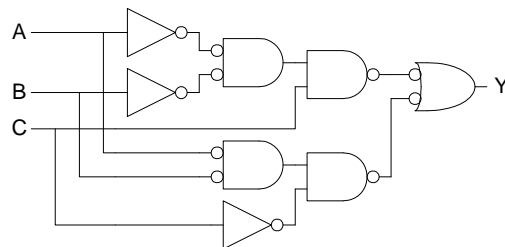

(c)

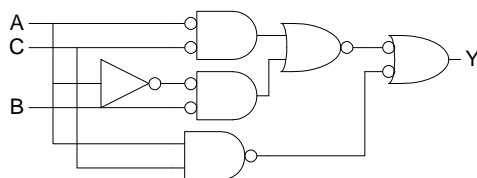

(d)

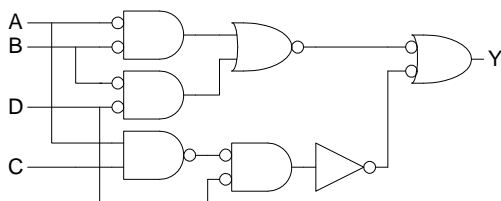

(e)

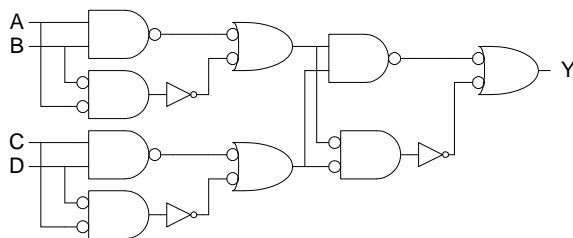

Exercise 2.13

- (a) $Y = AC + \overline{B}C$
- (b) $Y = \overline{A}$
- (c) $Y = \overline{A} + \overline{B}\overline{C} + \overline{B}\overline{D} + BD$

Exercise 2.15

(a)

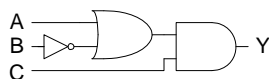

(b)

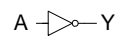

(c)

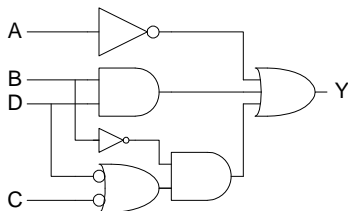

Exercise 2.17

(a) $Y = B + \bar{A}\bar{C}$



(b) $Y = \bar{A}B$

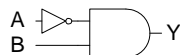

(c) $Y = A + \bar{B}\bar{C} + \bar{D}\bar{E}$

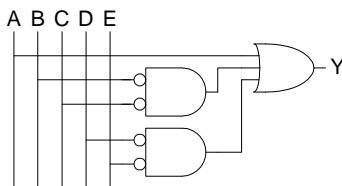

Exercise 2.19

4 gigarows = 4×2^{30} rows = 2^{32} rows, so the truth table has 32 inputs.

Exercise 2.21

Ben is correct. For example, the following function, shown as a K-map, has two possible minimal sum-of-products expressions. Thus, although $\overline{A}\overline{C}\overline{D}$ and $\overline{B}\overline{C}\overline{D}$ are both prime implicants, the minimal sum-of-products expression does not have both of them.

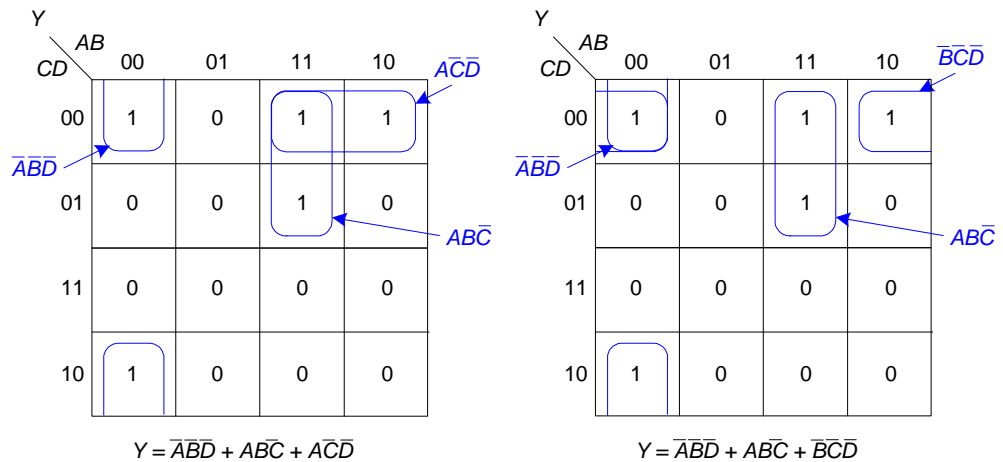

Exercise 2.23

B_2	B_1	B_0	$\overline{B_2} \cdot \overline{B_1} \cdot \overline{B_0}$	$\overline{B_2} + \overline{B_1} + \overline{B_0}$
0	0	0	1	1
0	0	1	1	1
0	1	0	1	1
0	1	1	1	1
1	0	0	1	1
1	0	1	1	1
1	1	0	1	1
1	1	1	0	0

Exercise 2.25

Y

CD \ AB	00	01	11	10
00	0	0	0	0
01	1	1	1	1
11	1	1	1	1
10	0	0	0	1

D (arrow to row 01)
A \bar{B} C (arrow to cell 11, 10)

$$Y = A\bar{B}C + D$$

Z

CD \ AB	00	01	11	10
00	0	0	1	0
01	0	1	1	1
11	0	1	1	0
10	0	0	0	0

A \bar{C} D (arrow to cell 01, 10)
BD (arrow to cell 11, 10)

$$Z = A\bar{C}D + BD$$

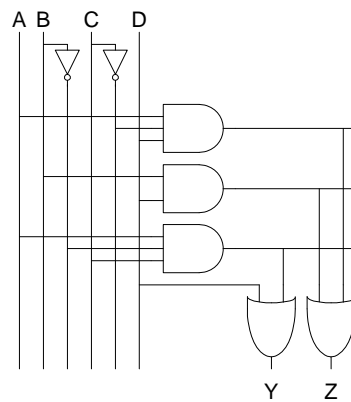

Exercise 2.27

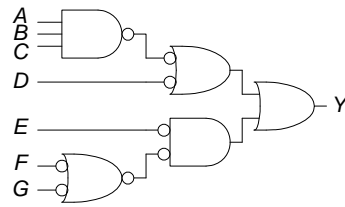

$$Y = ABC + \bar{D} + (\bar{F} + \bar{G})\bar{E}$$

$$= ABC + \bar{D} + \bar{E}\bar{F} + \bar{E}\bar{G}$$

Exercise 2.29

Two possible options are shown below:

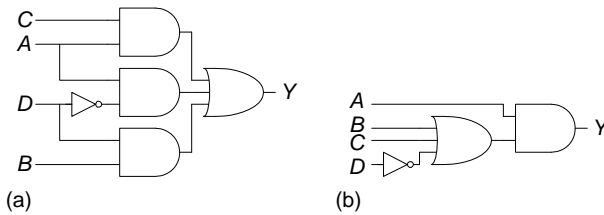

Exercise 2.31

$$Y = \bar{A}D + A\bar{B}\bar{C}\bar{D} + BD + CD = A\bar{B}\bar{C}\bar{D} + D(\bar{A} + B + C)$$

Exercise 2.33

The equation can be written directly from the description:

$$E = \bar{S}A + AL + H$$

Exercise 2.35

Decimal Value	A_3	A_2	A_1	A_0	D	P
0	0	0	0	0	0	0
1	0	0	0	1	0	0
2	0	0	1	0	0	1
3	0	0	1	1	1	1
4	0	1	0	0	0	0
5	0	1	0	1	0	1
6	0	1	1	0	1	0
7	0	1	1	1	0	1
8	1	0	0	0	0	0
9	1	0	0	1	1	0
10	1	0	1	0	0	0
11	1	0	1	1	0	1
12	1	1	0	0	1	0
13	1	1	0	1	0	1
14	1	1	1	0	0	0
15	1	1	1	1	1	0

P has two possible minimal solutions:

D

$A_{3:2}$	$A_{1:0}$	00	01	11	10
00		0	0	1	0
01		0	0	0	1
11		1	0	1	0
10		0	1	0	0

$$D = \bar{A}_3 \bar{A}_2 A_1 A_0 + \bar{A}_3 A_2 A_1 \bar{A}_0 + A_3 \bar{A}_2 \bar{A}_1 A_0 + A_3 A_2 \bar{A}_1 \bar{A}_0 + A_3 A_2 A_1 A_0$$

P

$A_{3:2}$	$A_{1:0}$	00	01	11	10
00		0	0	0	0
01		0	1	1	0
11		1	1	0	1
10		1	0	0	0

$$P = \bar{A}_3 A_2 A_0 + \bar{A}_3 A_1 A_0 + \bar{A}_3 \bar{A}_2 A_1 + A_2 A_1 A_0$$

$$P = \bar{A}_3 A_1 A_0 + \bar{A}_3 \bar{A}_2 A_1 + \bar{A}_2 A_1 A_0 + A_2 \bar{A}_1 A_0$$

Hardware implementations are below (implementing the first minimal equation given for P).

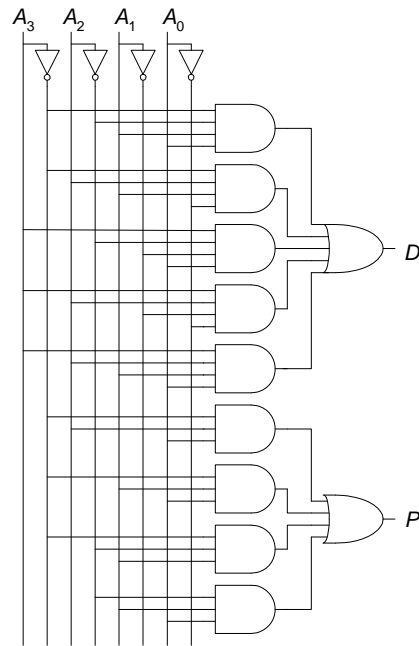

Exercise 2.37

The equations and circuit for $Y_{2:0}$ is the same as in Exercise 2.25, repeated here for convenience.

A_7	A_6	A_5	A_4	A_3	A_2	A_1	A_0	Y_2	Y_1	Y_0
0	0	0	0	0	0	0	0	0	0	0
0	0	0	0	0	0	0	1	0	0	0
0	0	0	0	0	0	1	X	0	0	1
0	0	0	0	0	1	X	X	0	1	0
0	0	0	0	1	X	X	X	0	1	1
0	0	0	1	X	X	X	X	1	0	0
0	0	1	X	X	X	X	X	1	0	1
0	1	X	X	X	X	X	X	1	1	0
1	X	X	X	X	X	X	X	1	1	1

$$Y_2 = A_7 + A_6 + A_5 + A_4$$

$$Y_1 = A_7 + A_6 + \overline{A_5} \overline{A_4} A_3 + \overline{A_5} \overline{A_4} A_2$$

$$Y_0 = A_7 + \overline{A_6}A_5 + \overline{A_6}\overline{A_4}A_3 + \overline{A_6}\overline{A_4}\overline{A_2}A_1$$

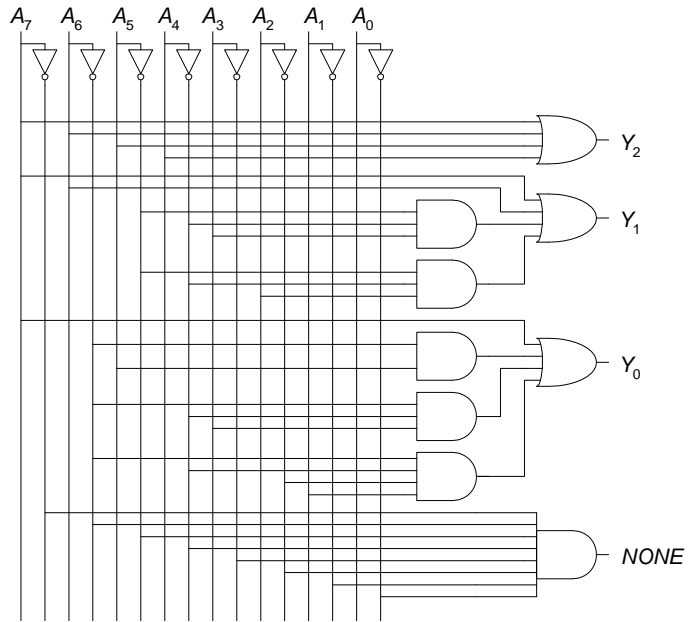

The truth table, equations, and circuit for $Z_{2:0}$ are as follows.

A_7	A_6	A_5	A_4	A_3	A_2	A_1	A_0	Z_2	Z_1	Z_0
0	0	0	0	0	0	1	1	0	0	0
0	0	0	0	0	1	0	1	0	0	0
0	0	0	0	1	0	0	1	0	0	0
0	0	0	1	0	0	0	1	0	0	0
0	0	1	0	0	0	0	1	0	0	0
0	1	0	0	0	0	0	1	0	0	0
1	0	0	0	0	0	0	1	0	0	0
0	0	0	0	0	1	1	X	0	0	1
0	0	0	0	1	0	1	X	0	0	1
0	0	0	1	0	0	1	X	0	0	1
0	0	1	0	0	0	1	X	0	0	1
0	1	0	0	0	0	1	X	0	0	1
1	0	0	0	0	0	1	X	0	0	1
0	0	0	0	1	1	X	X	0	1	0
0	0	0	1	0	1	X	X	0	1	0
0	0	1	0	0	1	X	X	0	1	0
0	1	0	0	0	1	X	X	0	1	0
1	0	0	0	0	1	X	X	0	1	0
0	0	0	1	1	X	X	X	0	1	1
0	0	1	0	1	X	X	X	0	1	1
0	1	0	0	1	X	X	X	0	1	1
1	0	0	0	1	X	X	X	0	1	1
0	0	1	1	X	X	X	X	1	0	0
0	1	0	1	X	X	X	X	1	0	0
1	0	0	1	X	X	X	X	1	0	0
0	1	1	X	X	X	X	X	1	0	1
1	0	1	X	X	X	X	X	1	0	1
1	1	X	X	X	X	X	X	1	1	0

$$Z_2 = A_4(A_5 + A_6 + A_7) + A_5(A_6 + A_7) + A_6A_7$$

$$Z_1 = A_2(A_3 + A_4 + A_5 + A_6 + A_7) + A_3(A_4 + A_5 + A_6 + A_7) + A_6A_7$$

$$Z_0 = A_1(A_2 + A_3 + A_4 + A_5 + A_6 + A_7) + A_3(A_4 + A_5 + A_6 + A_7) + A_5(A_6 + A_7)$$

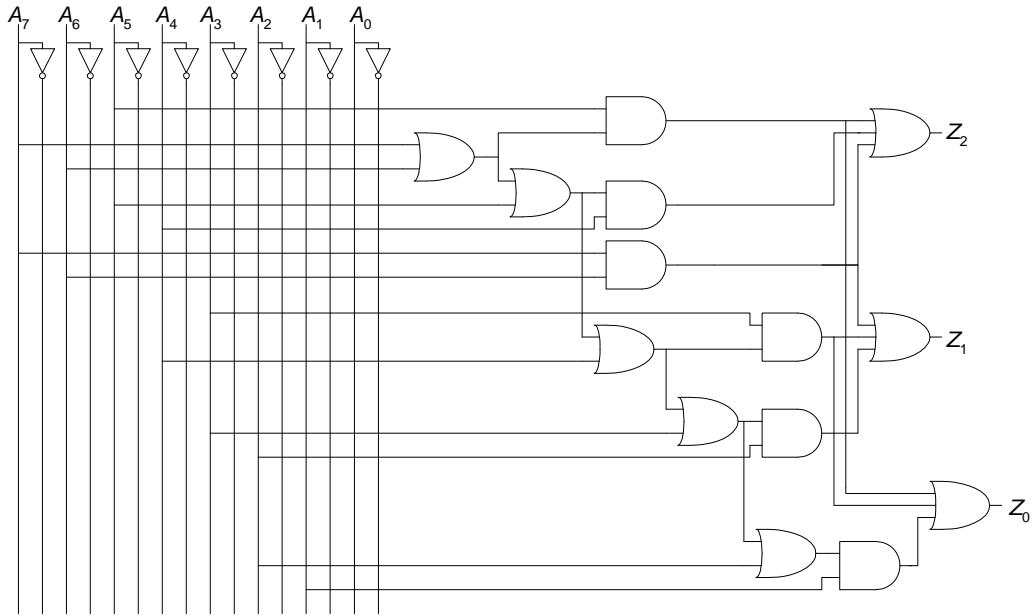

Exercise 2.39

$$Y = A + \overline{C \oplus D} = A + CD + \overline{C}\overline{D}$$

Exercise 2.41

A	B	C	Y
0	0	0	1
0	0	1	0
0	1	0	0
0	1	1	0
1	0	0	0
1	0	1	0
1	1	0	0
1	1	1	1

A	B	Y
0	0	\overline{C}
0	1	0
1	0	0
1	1	C

A	Y
0	$\overline{B}C$
1	BC

(a)

(b)

(c)

Exercise 2.43

$$t_{pd} = 3t_{pd_NAND2} = \mathbf{60\ ps}$$

$$t_{cd} = t_{cd_NAND2} = \mathbf{15\ ps}$$

Exercise 2.45

$$t_{pd} = t_{pd_NOT} + t_{pd_AND3}$$

$$= 15\ ps + 40\ ps$$

$$= \mathbf{55\ ps}$$

$$t_{cd} = t_{cd_AND3}$$

$$= \mathbf{30\ ps}$$

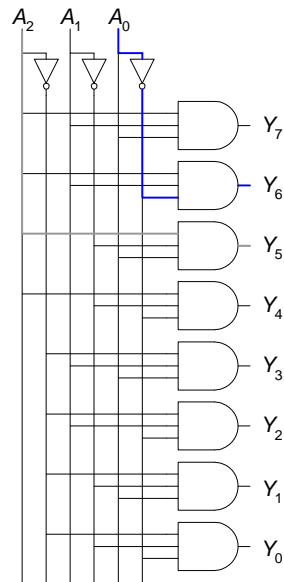

Exercise 2.47

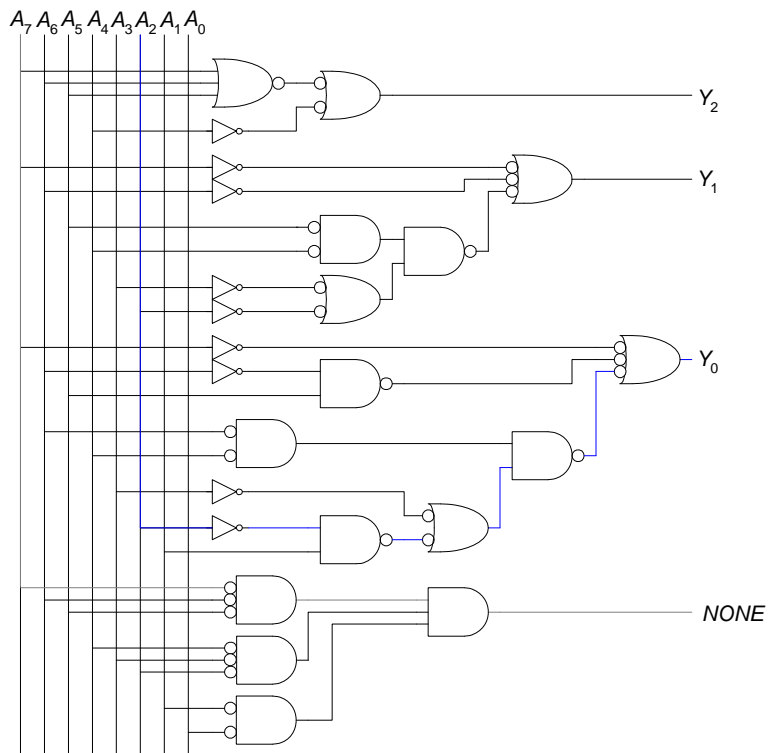

$$\begin{aligned}
 t_{pd} &= t_{pd_INV} + 3t_{pd_NAND2} + t_{pd_NAND3} \\
 &= [15 + 3(20) + 30] \text{ ps} \\
 &= \mathbf{105 \text{ ps}}
 \end{aligned}$$

$$\begin{aligned}
 t_{cd} &= t_{cd_NOT} + t_{cd_NAND2} \\
 &= [10 + 15] \text{ ps} \\
 &= \mathbf{25 \text{ ps}}
 \end{aligned}$$

Question 2.1

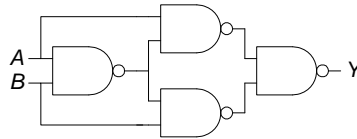

Question 2.3

A tristate buffer has two inputs and three possible outputs: 0, 1, and Z. One of the inputs is the data input and the other input is a control input, often called the *enable* input. When the enable input is 1, the tristate buffer transfers the data input to the output; otherwise, the output is high impedance, Z. Tristate buffers are used when multiple sources drive a single output at different times. One and only one tristate buffer is enabled at any given time.

Question 2.5

A circuit's contamination delay might be less than its propagation delay because the circuit may operate over a range of temperatures and supply voltages, for example, 3-3.6 V for LVCMOS (low voltage CMOS) chips. As temperature increases and voltage decreases, circuit delay increases. Also, the circuit may have different paths (critical and short paths) from the input to the output. A gate itself may have varying delays between different inputs and the output, affecting the gate's critical and short paths. For example, for a two-input NAND gate, a HIGH to LOW transition requires two nMOS transistor delays, whereas a LOW to HIGH transition requires a single pMOS transistor delay.

CHAPTER 3

Exercise 3.1

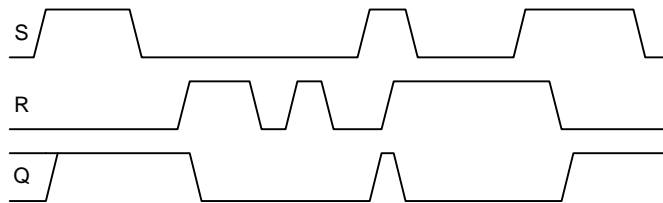

Exercise 3.3

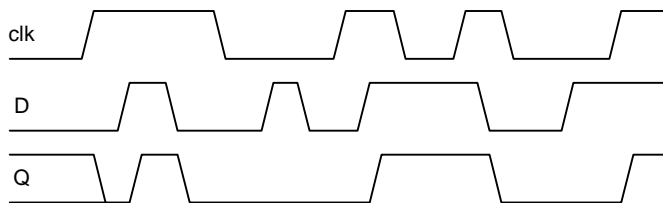

Exercise 3.5

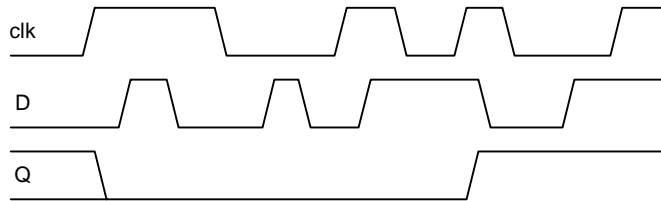

Exercise 3.7

The circuit is sequential because it involves feedback and the output depends on previous values of the inputs. This is a SR latch. When $\bar{S} = 0$ and $\bar{R} = 1$, the circuit sets Q to 1. When $\bar{S} = 1$ and $\bar{R} = 0$, the circuit resets Q to 0. When both \bar{S} and \bar{R} are 1, the circuit remembers the old value. And when both \bar{S} and \bar{R} are 0, the circuit drives both outputs to 1.

Exercise 3.9

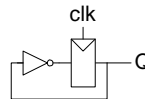

Exercise 3.11

If A and B have the same value, C takes on that value. Otherwise, C retains its old value.

Exercise 3.13

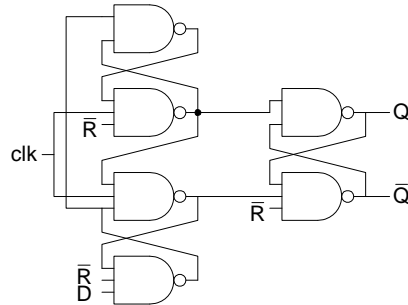

Exercise 3.15

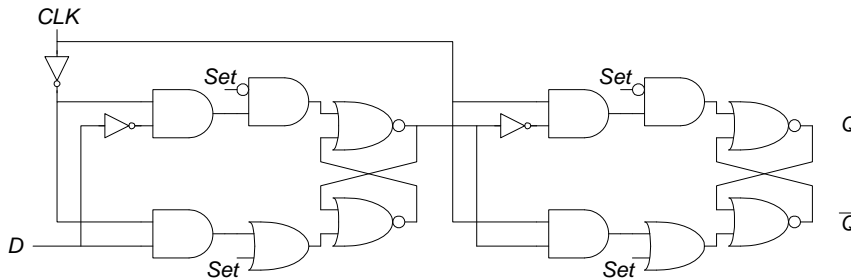

Exercise 3.17

If N is even, the circuit is stable and will not oscillate.

Exercise 3.19

The system has at least five bits of state to represent the 24 floors that the elevator might be on.

Exercise 3.21

The FSM could be factored into four independent state machines, one for each student. Each of these machines has five states and requires 3 bits, so at least 12 bits of state are required for the factored design.

Exercise 3.23

This finite state machine asserts the output Q when A AND B is TRUE.

state	encoding $s_{1:0}$
S0	00
S1	01
S2	10

TABLE 3.1 State encoding for Exercise 3.23

current state		inputs		next state		output
s_1	s_0	a	b	s'_1	s'_0	q
0	0	0	X	0	0	0
0	0	1	X	0	1	0
0	1	X	0	0	0	0
0	1	X	1	1	0	0
1	0	1	1	1	0	1
1	0	0	0	0	0	0
1	0	0	1	0	0	0
1	0	1	0	0	0	0

TABLE 3.2 Combined state transition and output table with binary encodings for Exercise 3.23

$$S'_1 = \overline{S_1}S_0B + S_1AB$$

$$S'_0 = \overline{S_1}\overline{S_0}A$$

$$Q' = S_1AB$$

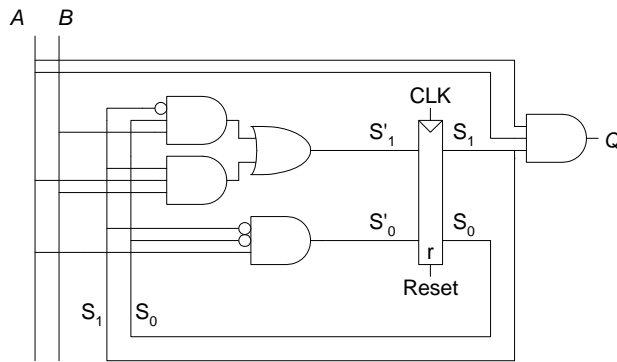

Exercise 3.25

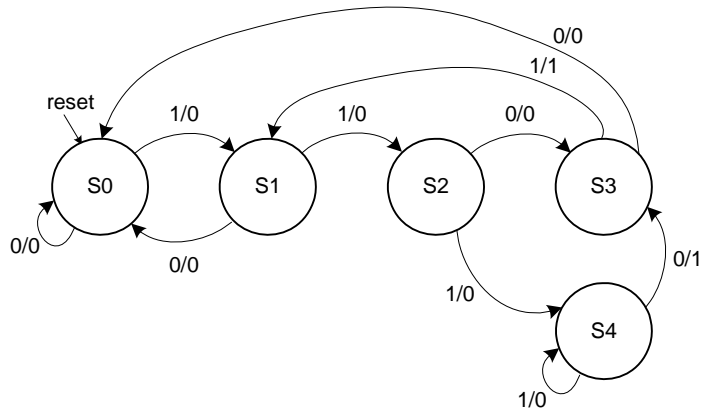

state	encoding $s_1:0$
S0	000
S1	001

TABLE 3.3 State encoding for Exercise 3.25

state	encoding $s_{1:0}$
S2	010
S3	100
S4	101

TABLE 3.3 State encoding for Exercise 3.25

current state			input	next state			output
s_2	s_1	s_0	a	s'_2	s'_1	s'_0	q
0	0	0	0	0	0	0	0
0	0	0	1	0	0	1	0
0	0	1	0	0	0	0	0
0	0	1	1	0	1	0	0
0	1	0	0	1	0	0	0
0	1	0	1	1	0	1	0
1	0	0	0	0	0	0	0
1	0	0	1	0	0	1	1
1	0	1	0	1	0	0	1
1	0	1	1	1	0	1	0

TABLE 3.4 Combined state transition and output table with binary encodings for Exercise 3.25

$$S'_2 = \overline{S}_2 \overline{S}_1 \overline{S}_0 + S_2 \overline{S}_1 S_0$$

$$S'_1 = \overline{S}_2 \overline{S}_1 S_0 A$$

$$S'_0 = A(\overline{S}_2 \overline{S}_0 + S_2 \overline{S}_1)$$

$$Q = S_2 \overline{S}_1 \overline{S}_0 A + S_2 \overline{S}_1 S_0 \overline{A}$$

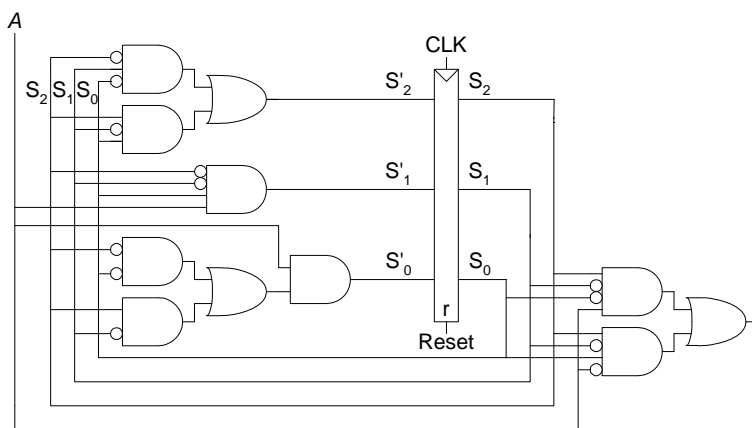

Exercise 3.27

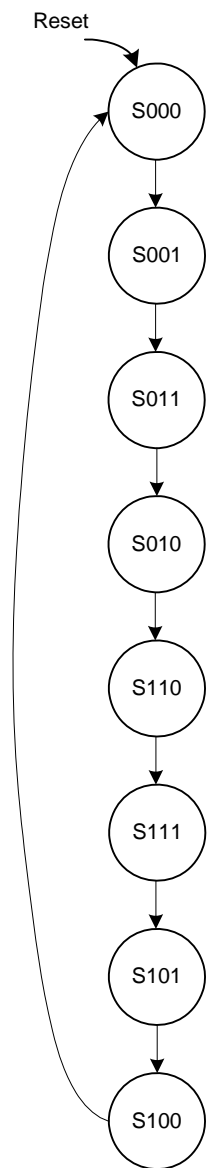

FIGURE 3.1 State transition diagram for Exercise 3.27

current state $s_{2:0}$	next state $s'_{2:0}$
000	001
001	011
011	010
010	110
110	111
111	101
101	100
100	000

TABLE 3.5 State transition table for Exercise 3.27

$$S'_2 = S_1 \overline{S_0} + S_2 S_0$$

$$S'_1 = \overline{S_2} S_0 + S_1 \overline{S_0}$$

$$S'_0 = \overline{S_2 \oplus S_1}$$

$$Q_2 = S_2$$

$$Q_1 = S_1$$

$$Q_0 = S_0$$

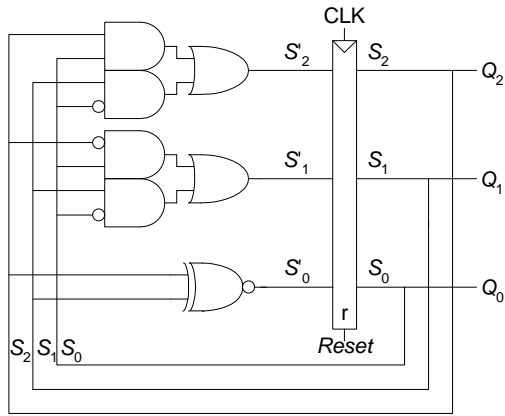

FIGURE 3.2 Hardware for Gray code counter FSM for Exercise 3.27

Exercise 3.29

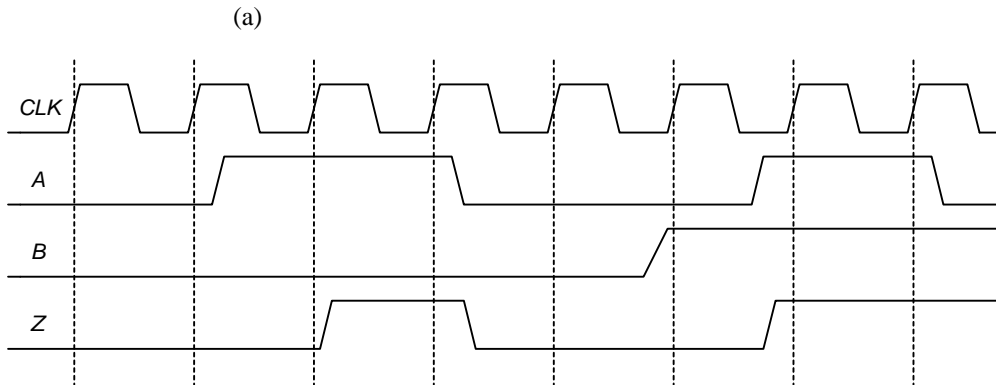

FIGURE 3.3 Waveform showing Z output for Exercise 3.29

(b) This FSM is a Mealy FSM because the output depends on the current value of the input as well as the current state.

(c)

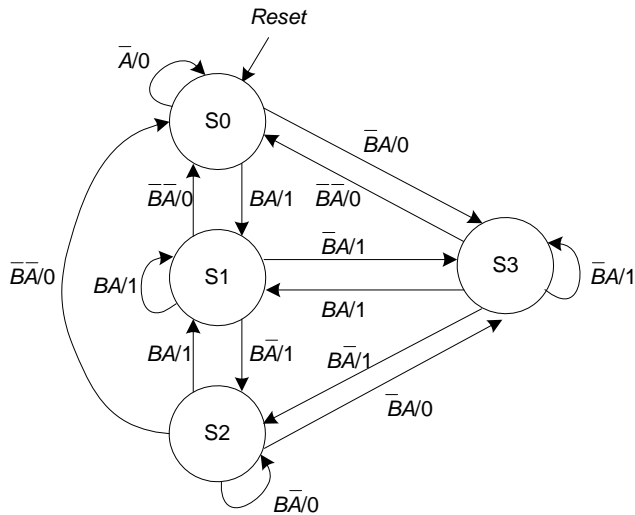

FIGURE 3.4 State transition diagram for Exercise 3.29

(Note: another viable solution would be to allow the state to transition from S0 to S1 on $\overline{B}\overline{A}/0$. The arrow from S0 to S0 would then be $\overline{B}\overline{A}/0$.)

current state $s_{1:0}$	inputs		next state $s'_{1:0}$	output z
	b	a		
00	X	0	00	0
00	0	1	11	0
00	1	1	01	1
01	0	0	00	0
01	0	1	11	1
01	1	0	10	1
01	1	1	01	1
10	0	X	00	0
10	1	0	10	0

TABLE 3.6 State transition table for Exercise 3.29

current state $s_{1:0}$	inputs		next state $s'_{1:0}$	output z
	b	a		
10	1	1	01	1
11	0	0	00	0
11	0	1	11	1
11	1	0	10	1
11	1	1	01	1

TABLE 3.6 State transition table for Exercise 3.29

$$S'_1 = \bar{B}A(\bar{S}_1 + S_0) + B\bar{A}(S_1 + \bar{S}_0)$$

$$S'_0 = A(\bar{S}_1 + S_0 + B)$$

$$Z = BA + S_0(A + B)$$

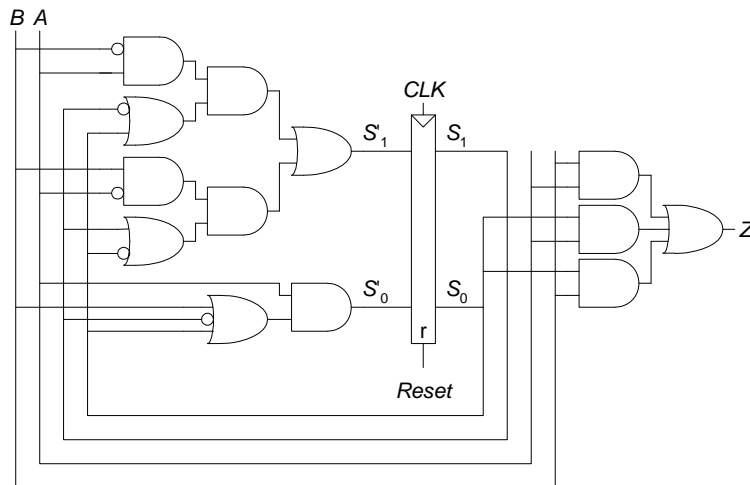

FIGURE 3.5 Hardware for FSM of Exercise 3.26

Note: One could also build this functionality by registering input A , producing both the logical AND and OR of input A and its previous (registered)

value, and then muxing the two operations using B . The output of the mux is Z :
 $Z = A\text{Aprev}$ (if $B = 0$); $Z = A + A\text{prev}$ (if $B = 1$).

Exercise 3.31

This finite state machine is a divide-by-two counter (see Section 3.4.2) when $X = 0$. When $X = 1$, the output, Q , is HIGH.

current state		input	next state	
s_1	s_0	x	s'_1	s'_0
0	0	0	0	1
0	0	1	1	1
0	1	0	0	0
0	1	1	1	0
1	X	X	0	1

TABLE 3.7 State transition table with binary encodings for Exercise 3.31

current state		output
s_1	s_0	q
0	0	0
0	1	1
1	X	1

TABLE 3.8 Output table for Exercise 3.31

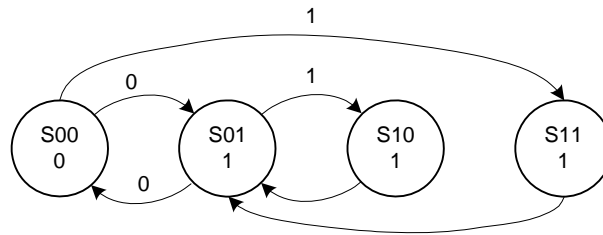

Exercise 3.33

(a) First, we calculate the propagation delay through the combinational logic:

$$\begin{aligned}
 t_{pd} &= 3t_{pd_XOR} \\
 &= 3 \times 100 \text{ ps} \\
 &= \mathbf{300 \text{ ps}}
 \end{aligned}$$

Next, we calculate the cycle time:

$$\begin{aligned}
 T_c &\geq t_{pcq} + t_{pd} + t_{setup} \\
 &\geq [70 + 300 + 60] \text{ ps} \\
 &= 430 \text{ ps}
 \end{aligned}$$

$$f = 1 / 430 \text{ ps} = \mathbf{2.33 \text{ GHz}}$$

(b)

$$T_c \geq t_{pcq} + t_{pd} + t_{setup} + t_{skew}$$

Thus,

$$\begin{aligned}
 t_{skew} &\leq T_c - (t_{pcq} + t_{pd} + t_{setup}), \text{ where } T_c = 1 / 2 \text{ GHz} = 500 \text{ ps} \\
 &\leq [500 - 430] \text{ ps} = \mathbf{70 \text{ ps}}
 \end{aligned}$$

(c)

First, we calculate the contamination delay through the combinational logic:

$$\begin{aligned}
 t_{cd} &= t_{cd_XOR} \\
 &= 55 \text{ ps}
 \end{aligned}$$

$$t_{ccq} + t_{cd} > t_{hold} + t_{skew}$$

Thus,

$$\begin{aligned}
 t_{skew} &< (t_{ccq} + t_{cd}) - t_{hold} \\
 &< (50 + 55) - 20 \\
 &< \mathbf{85 \text{ ps}}
 \end{aligned}$$

$$\begin{aligned}
 t_{\text{skew}} &< (t_{\text{ccq}} + t_{\text{cd_CLB}}) - t_{\text{hold}} \\
 &< [(0.5 + 0.3) - 0] \text{ ns} \\
 &< \mathbf{0.8 \text{ ns} = 800 \text{ ps}}
 \end{aligned}$$

Exercise 3.37

$$P(\text{failure})/\text{sec} = 1/\text{MTBF} = 1/(50 \text{ years} * 3.15 * 10^7 \text{ sec/year}) = \mathbf{6.34 * 10^{-10}} \quad (\text{EQ 3.26})$$

$$\begin{aligned}
 P(\text{failure})/\text{sec} \text{ waiting for one clock cycle: } &N * (T_0/T_c) * e^{-(T_c - t_{\text{setup}})/\text{Tau}} \\
 &= 0.5 * (110/1000) * e^{-(1000-70)/100} = 5.0 * 10^{-6}
 \end{aligned}$$

$$\begin{aligned}
 P(\text{failure})/\text{sec} \text{ waiting for two clock cycles: } &N * (T_0/T_c) * [e^{-(T_c - t_{\text{setup}})/\text{Tau}}]^2 \\
 &= 0.5 * (110/1000) * [e^{-(1000-70)/100}]^2 = 4.6 * 10^{-10}
 \end{aligned}$$

This is just less than the required probability of failure ($6.34 * 10^{-10}$). Thus, **2 cycles** of waiting is just adequate to meet the MTBF.

Exercise 3.39

We assume a two flip-flop synchronizer. The most significant impact on the probability of failure comes from the exponential component. If we ignore the T_0/T_c term in the probability of failure equation, assuming it changes little with increases in cycle time, we get:

$$\begin{aligned}
 P(\text{failure}) &= e^{-\frac{t}{\tau}} \\
 \text{MTBF} &= \frac{1}{P(\text{failure})} = e^{\frac{T_c - t_{\text{setup}}}{\tau}} \\
 \frac{\text{MTBF}_2}{\text{MTBF}_1} &= 10 = e^{\frac{T_{c2} - T_{c1}}{30 \text{ ps}}}
 \end{aligned}$$

Solving for $T_{c2} - T_{c1}$, we get:

$$T_{c2} - T_{c1} = 69 \text{ ps}$$

Thus, the clock cycle time must increase by **69 ps**. This holds true for cycle times much larger than T_0 (20 ps) and the increased time (69 ps).

Question 3.1

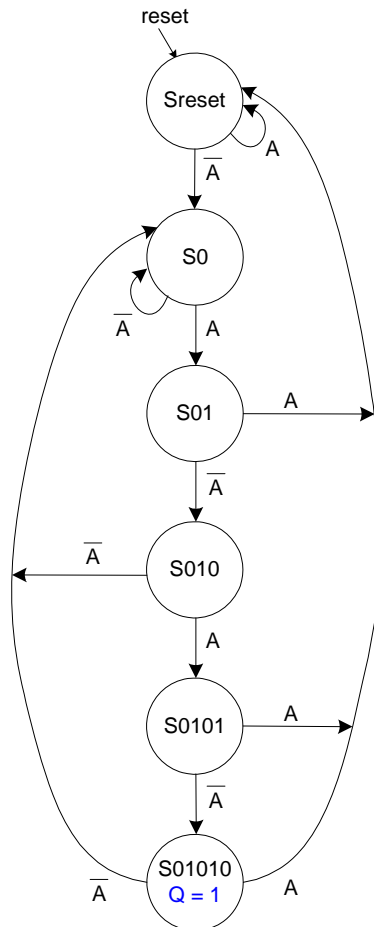

FIGURE 3.7 State transition diagram for Question 3.1

current state $s_{5:0}$	input	next state $s'_{5:0}$
	a	
000001	0	000010
000001	1	000001
000010	0	000010
000010	1	000100
000100	0	001000
000100	1	000001
001000	0	000010
001000	1	010000
010000	0	100000
010000	1	000001
100000	0	000010
100000	1	000001

TABLE 3.9 State transition table for Question 3.1

$$S'_5 = S_4A$$

$$S'_4 = S_3A$$

$$S'_3 = S_2A$$

$$S'_2 = S_1A$$

$$S'_1 = A(S_1 + S_3 + S_5)$$

$$S'_0 = A(S_0 + S_2 + S_4 + S_5)$$

$$Q = S_5$$

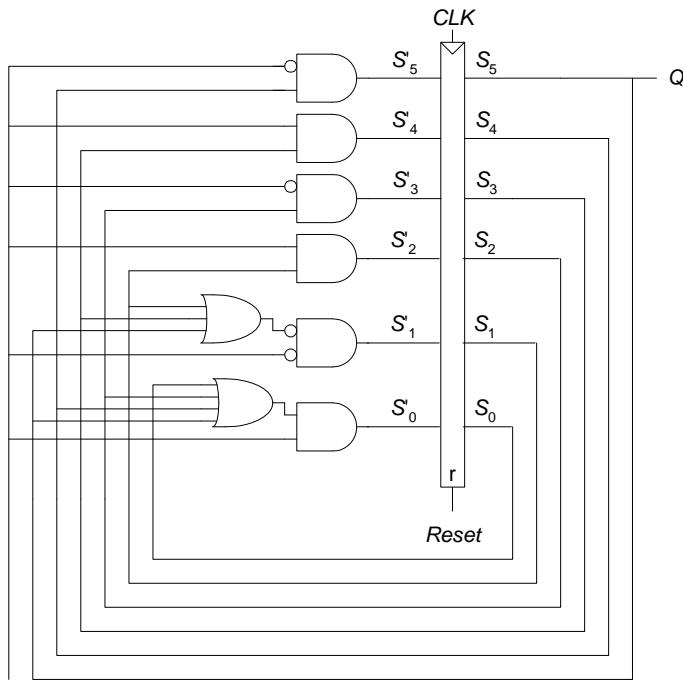

FIGURE 3.8 Finite state machine hardware for Question 3.1

Question 3.3

A latch allows input D to flow through to the output Q when the clock is HIGH. A flip-flop allows input D to flow through to the output Q at the clock edge. A flip-flop is preferable in systems with a single clock. Latches are preferable in *two-phase clocking* systems, with two clocks. The two clocks are used to eliminate system failure due to hold time violations. Both the phase and frequency of each clock can be modified independently.

Question 3.5

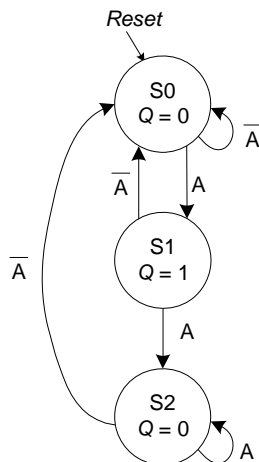

FIGURE 3.9 State transition diagram for edge detector circuit of Question 3.5

current state $s_{1:0}$	input	next state $s'_{1:0}$
	a	
00	0	00
00	1	01
01	0	00
01	1	10
10	0	00
10	1	10

TABLE 3.10 State transition table for Question 3.5

$$S'_1 = AS_1$$

$$S'_0 = AS_1S_0$$

$$Q = S_1$$

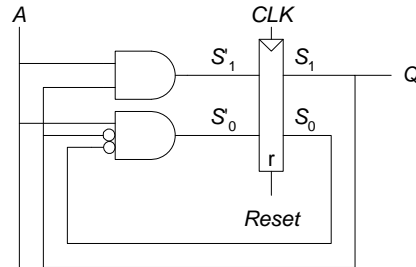

FIGURE 3.10 Finite state machine hardware for Question 3.5

Question 3.7

A flip-flop with a negative hold time allows D to start changing *before* the clock edge arrives.

Question 3.9

Without the added buffer, the propagation delay through the logic, t_{pd} , must be less than or equal to $T_c - (t_{pcq} + t_{setup})$. However, if you add a buffer to the clock input of the receiver, the clock arrives at the receiver later. The earliest that the clock edge arrives at the receiver is t_{cd_BUF} after the actual clock edge. Thus, the propagation delay through the logic is now given an extra t_{cd_BUF} . So, t_{pd} now must be less than $T_c + t_{cd_BUF} - (t_{pcq} + t_{setup})$.

CHAPTER 4

Note: the HDL files given in the following solutions are available on the textbook's companion website at:

<http://textbooks.elsevier.com/9780123704979>

Exercise 4.1

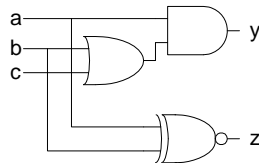

Exercise 4.3

SystemVerilog

```

module xor_4(input logic [3:0] a,
            output logic y);

    assign y = ^a;
endmodule

```

VHDL

```

library IEEE; use IEEE.STD_LOGIC_1164.all;

entity xor_4 is
    port(a: in STD_LOGIC_VECTOR(3 downto 0);
         y: out STD_LOGIC);
end;

architecture synth of xor_4 is
begin
    y <= a(3) xor a(2) xor a(1) xor a(0);
end;

```

Exercise 4.5

SystemVerilog

```

module minority(input logic a, b, c
              output logic y);

    assign y = ~a & ~b | ~a & ~c | ~b & ~c;
endmodule

```

VHDL

```

library IEEE; use IEEE.STD_LOGIC_1164.all;

entity minority is
    port(a, b, c: in STD_LOGIC;
         y: out STD_LOGIC);
end;

architecture synth of minority is
begin
    y <= ((not a) and (not b)) or ((not a) and (not c))
        or ((not b) and (not c));
end;

```

Exercise 4.7

ex4_7.tv file:

```

0000_111_1110
0001_011_0000
0010_110_1101
0011_111_1001
0100_011_0011
0101_101_1011
0110_101_1111
0111_111_0000
1000_111_1111
1001_111_1011
1010_111_0111
1011_001_1111
1100_000_1101
1101_011_1101
1110_100_1111
1111_100_0111

```

Option 1:

SystemVerilog

```

module ex4_7_testbench();
    logic        clk, reset;
    logic [3:0]  data;
    logic [6:0]  s_expected;
    logic [6:0]  s;
    logic [31:0] vectornum, errors;
    logic [10:0] testvectors[10000:0];

    // instantiate device under test
    sevenseg dut(data, s);

    // generate clock
    always
    begin
        clk = 1; #5; clk = 0; #5;
    end

    // at start of test, load vectors
    // and pulse reset
    initial
    begin
        $readmemb("ex4_7.tv", testvectors);
        vectornum = 0; errors = 0;
        reset = 1; #27; reset = 0;
    end

    // apply test vectors on rising edge of clk
    always @(posedge clk)
    begin
        #1; {data, s_expected} =
            testvectors[vectornum];
    end

    // check results on falling edge of clk
    always @(negedge clk)
    if (~reset) begin // skip during reset
        if (s != s_expected) begin
            $display("Error: inputs = %h", data);
            $display("  outputs = %b (%b expected)",
                s, s_expected);
            errors = errors + 1;
        end
        vectornum = vectornum + 1;
        if (testvectors[vectornum] == 11'bx) begin
            $display("%d tests completed with %d errors",
                vectornum, errors);
            $finish;
        end
    end
endmodule

```

VHDL

```

library IEEE; use IEEE.STD_LOGIC_1164.all;
use STD.TEXTIO.all;
use IEEE.STD_LOGIC_UNSIGNED.all;
use IEEE.STD_LOGIC_ARITH.all;

entity ex4_7_testbench is -- no inputs or outputs
end;

architecture sim of ex4_7_testbench is
    component seven_seg_decoder
        port(data: in STD_LOGIC_VECTOR(3 downto 0);
             segments: out STD_LOGIC_VECTOR(6 downto 0));
    end component;
    signal data: STD_LOGIC_VECTOR(3 downto 0);
    signal s: STD_LOGIC_VECTOR(6 downto 0);
    signal clk, reset: STD_LOGIC;
    signal s_expected: STD_LOGIC_VECTOR(6 downto 0);
    constant MEMSIZE: integer := 10000;
    type tarray is array(MEMSIZE downto 0) of
        STD_LOGIC_VECTOR(10 downto 0);
    signal testvectors: tarray;
    shared variable vectornum, errors: integer;
begin
    -- instantiate device under test
    dut: seven_seg_decoder port map(data, s);

    -- generate clock
    process begin
        clk <= '1'; wait for 5 ns;
        clk <= '0'; wait for 5 ns;
    end process;

    -- at start of test, load vectors
    -- and pulse reset
    process is
        file tv: TEXT;
        variable i, j: integer;
        variable L: line;
        variable ch: character;
    begin
        -- read file of test vectors
        i := 0;
        FILE_OPEN(tv, "ex4_7.tv", READ_MODE);
        while not endfile(tv) loop
            readline(tv, L);
            for j in 10 downto 0 loop
                read(L, ch);
                if (ch = '_') then read(L, ch);
                end if;
                if (ch = '0') then
                    testvectors(i)(j) <= '0';
                else testvectors(i)(j) <= '1';
                end if;
            end loop;
            i := i + 1;
        end loop;
    end process;
end;

```

(VHDL continued on next page)

(continued from previous page)

VHDL

```
vectornum := 0; errors := 0;
reset <= '1'; wait for 27 ns; reset <= '0';
wait;
end process;

-- apply test vectors on rising edge of clk
process (clk) begin
    if (clk'event and clk = '1') then

        data <= testvectors(vectornum)(10 downto 7)
            after 1 ns;
        s_expected <= testvectors(vectornum)(6 downto 0)
            after 1 ns;
        end if;
    end process;

-- check results on falling edge of clk
process (clk) begin
    if (clk'event and clk = '0' and reset = '0') then
        assert s = s_expected
            report "data = " &
                integer'image(CONV_INTEGER(data)) &
                "; s = " &
                integer'image(CONV_INTEGER(s)) &
                "; s_expected = " &
                integer'image(CONV_INTEGER(s_expected));
        if (s /= s_expected) then
            errors := errors + 1;
        end if;
        vectornum := vectornum + 1;
        if (is_x(testvectors(vectornum))) then
            if (errors = 0) then
                report "Just kidding -- " &
                    integer'image(vectornum) &
                    " tests completed successfully."
                    severity failure;
            else
                report integer'image(vectornum) &
                    " tests completed, errors = " &
                    integer'image(errors)
                    severity failure;
            end if;
        end if;
    end process;
end;
```

Option 2 (VHDL only):

VHDL

```

library IEEE; use IEEE.STD_LOGIC_1164.all;
use STD.TEXTIO.all;
use work.txt_util.all;

entity ex4_7_testbench is -- no inputs or outputs
end;

architecture sim of ex4_7_testbench is
  component seven_seg_decoder
    port(data:      in  STD_LOGIC_VECTOR(3 downto 0);
          segments: out STD_LOGIC_VECTOR(6 downto 0));
  end component;
  signal data: STD_LOGIC_VECTOR(3 downto 0);
  signal s:    STD_LOGIC_VECTOR(6 downto 0);
  signal clk, reset: STD_LOGIC;
  signal s_expected: STD_LOGIC_VECTOR(6 downto 0);
  constant MEMSIZE: integer := 10000;
  type tarray is array(MEMSIZE downto 0) of
    STD_LOGIC_VECTOR(10 downto 0);
  signal testvectors: tarray;
  shared variable vectornum, errors: integer;
begin
  -- instantiate device under test
  dut: seven_seg_decoder port map(data, s);

  -- generate clock
  process begin
    clk <= '1'; wait for 5 ns;
    clk <= '0'; wait for 5 ns;
  end process;

  -- at start of test, load vectors
  -- and pulse reset
  process is
    file tv: TEXT;
    variable i, j: integer;
    variable L: line;
    variable ch: character;
  begin
    -- read file of test vectors
    i := 0;
    FILE_OPEN(tv, "ex4_7.tv", READ_MODE);
    while not endfile(tv) loop
      readline(tv, L);
      for j in 10 downto 0 loop
        read(L, ch);
        if (ch = '_') then read(L, ch);
        end if;
        if (ch = '0') then
          testvectors(i)(j) <= '0';
        else testvectors(i)(j) <= '1';
        end if;
      end loop;
      i := i + 1;
    end loop;

    vectornum := 0; errors := 0;
    reset <= '1'; wait for 27 ns; reset <= '0';

    wait;
  end process;

  -- apply test vectors on rising edge of clk
  process (clk) begin
    if (clk'event and clk = '1') then
      data <= testvectors(vectornum)(10 downto 7)
        after 1 ns;
      s_expected <= testvectors(vectornum)(6 downto 0)
        after 1 ns;
    end if;
  end process;

  -- check results on falling edge of clk
  process (clk) begin
    if (clk'event and clk = '0' and reset = '0') then
      assert s = s_expected
        report "data = " & str(data) &
          "; s = " & str(s) &
            "; s_expected = " & str(s_expected);
      if (s /= s_expected) then
        errors := errors + 1;
      end if;
      vectornum := vectornum + 1;
      if (is_x(testvectors(vectornum))) then
        if (errors = 0) then
          report "Just kidding -- " &
            integer'image(vectornum) &
              " tests completed successfully."
            severity failure;
        else
          report integer'image(vectornum) &
            " tests completed, errors = " &
              integer'image(errors)
            severity failure;
        end if;
      end if;
    end process;
  end;
end;

```

(see Web site for file: *txt_util.vhd*)

Exercise 4.9

SystemVerilog

```
module ex4_9
  (input logic a, b, c,
   output logic y);

  mux8 #(1) mux8_1(1'b1, 1'b0, 1'b0, 1'b1,
                  1'b1, 1'b1, 1'b0, 1'b0,
                  {a,b,c}, y);

endmodule
```

VHDL

```
library IEEE; use IEEE.STD_LOGIC_1164.all;

entity ex4_9 is
  port(a,
        b,
        c: in STD_LOGIC;
        y: out STD_LOGIC_VECTOR(0 downto 0));
end;

architecture struct of ex4_9 is
  component mux8
    generic(width: integer);
    port(d0, d1, d2, d3, d4, d5, d6,
          d7: in STD_LOGIC_VECTOR(width-1 downto 0);
          s: in STD_LOGIC_VECTOR(2 downto 0);
          y: out STD_LOGIC_VECTOR(width-1 downto 0));
  end component;
  signal sel: STD_LOGIC_VECTOR(2 downto 0);
begin
  sel <= a & b & c;

  mux8_1: mux8 generic map(1)
    port map("1", "0", "0", "1",
             "1", "1", "0", "0",
             sel, y);
end;
```

Exercise 4.11

A shift register with feedback, shown below, cannot be correctly described with blocking assignments.

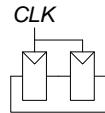
**Exercise 4.13**

SystemVerilog

```
module decoder2_4(input logic [1:0] a,
                 output logic [3:0] y);
    always_comb
        case (a)
            2'b00: y = 4'b0001;
            2'b01: y = 4'b0010;
            2'b10: y = 4'b0100;
            2'b11: y = 4'b1000;
        endcase
endmodule
```

VHDL

```
library IEEE; use IEEE.STD_LOGIC_1164.all;

entity decoder2_4 is
    port(a: in STD_LOGIC_VECTOR(1 downto 0);
         y: out STD_LOGIC_VECTOR(3 downto 0));
end;

architecture synth of decoder2_4 is
begin
    process(all) begin
        case a is
            when "00" => y <= "0001";
            when "01" => y <= "0010";
            when "10" => y <= "0100";
            when "11" => y <= "1000";
            when others => y <= "0000";
        end case;
    end process;
end;
```

Exercise 4.15

(a) $Y = AC + \overline{A}\overline{B}C$

SystemVerilog

```
module ex4_15a(input logic a, b, c,
              output logic y);
    assign y = (a & c) | (~a & ~b & c);
endmodule
```

VHDL

```
library IEEE; use IEEE.STD_LOGIC_1164.all;
entity ex4_15a is
    port(a, b, c: in STD_LOGIC;
         y: out STD_LOGIC);
end;
architecture behave of ex4_15a is
begin
    y <= (not a and not b and c) or (not b and c);
end;
```

(b) $Y = \overline{A}\overline{B} + \overline{A}B\overline{C} + \overline{\overline{A + C}}$

SystemVerilog

```
module ex4_15b(input logic a, b, c,
              output logic y);
    assign y = (~a & ~b) | (~a & b & ~c) | ~(a | ~c);
endmodule
```

VHDL

```
library IEEE; use IEEE.STD_LOGIC_1164.all;
entity ex4_15b is
    port(a, b, c: in STD_LOGIC;
         y: out STD_LOGIC);
end;
architecture behave of ex4_15b is
begin
    y <= ((not a) and (not b)) or ((not a) and b and
    (not c)) or (not(a or (not c)));
end;
```

(c) $Y = \overline{A}\overline{B}\overline{C}\overline{D} + \overline{A}\overline{B}C + \overline{A}B\overline{C}\overline{D} + ABD + \overline{A}\overline{B}C\overline{D} + \overline{B}\overline{C}\overline{D} + \overline{A}$

SystemVerilog

```
module ex4_15c(input logic a, b, c, d,
              output logic y);
    assign y = (~a & ~b & ~c & ~d) | (a & ~b & ~c) |
    (a & ~b & c & ~d) | (a & b & d) |
    (~a & ~b & c & ~d) | (b & ~c & d) | ~a;
endmodule
```

VHDL

```
library IEEE; use IEEE.STD_LOGIC_1164.all;
entity ex4_15c is
    port(a, b, c, d: in STD_LOGIC;
         y: out STD_LOGIC);
end;
architecture behave of ex4_15c is
begin
    y <= ((not a) and (not b) and (not c) and (not d)) or
    (a and (not b) and (not c)) or
    (a and (not b) and c and (not d)) or
    (a and b and d) or
    ((not a) and (not b) and c and (not d)) or
    (b and (not c) and d) or (not a);
end;
```

Exercise 4.17

SystemVerilog

```
module ex4_17(input logic a, b, c, d, e, f, g
             output logic y);

    logic n1, n2, n3, n4, n5;

    assign n1 = ~(a & b & c);
    assign n2 = ~(n1 & d);
    assign n3 = ~(f & g);
    assign n4 = ~(n3 | e);
    assign n5 = ~(n2 | n4);
    assign y = ~(n5 & n5);
endmodule
```

VHDL

```
library IEEE; use IEEE.STD_LOGIC_1164.all;

entity ex4_17 is
    port(a, b, c, d, e, f, g: in STD_LOGIC;
         y: out STD_LOGIC);
end;

architecture synth of ex4_17 is
    signal n1, n2, n3, n4, n5: STD_LOGIC;
begin
    n1 <= not(a and b and c);
    n2 <= not(n1 and d);
    n3 <= not(f and g);
    n4 <= not(n3 or e);
    n5 <= not(n2 or n4);
    y <= not (n5 or n5);
end;
```

Exercise 4.19

SystemVerilog

```

module ex4_18(input logic [3:0] a,
              output logic   p, d);

  always_comb
  case (a)
    0: {p, d} = 2'b00;
    1: {p, d} = 2'b00;
    2: {p, d} = 2'b10;
    3: {p, d} = 2'b11;
    4: {p, d} = 2'b00;
    5: {p, d} = 2'b10;
    6: {p, d} = 2'b01;
    7: {p, d} = 2'b10;
    8: {p, d} = 2'b00;
    9: {p, d} = 2'b01;
   10: {p, d} = 2'b00;
   11: {p, d} = 2'b10;
   12: {p, d} = 2'b01;
   13: {p, d} = 2'b10;
   14: {p, d} = 2'b00;
   15: {p, d} = 2'b01;
  endcase
endmodule

```

VHDL

```

library IEEE; use IEEE.STD_LOGIC_1164.all;

entity ex4_18 is
  port(a:   in  STD_LOGIC_VECTOR(3 downto 0);
       p, d: out STD_LOGIC);
end;

architecture synth of ex4_18 is
  signal vars: STD_LOGIC_VECTOR(1 downto 0);
begin
  p <= vars(1);
  d <= vars(0);
  process(all) begin
    case a is
      when X"0" => vars <= "00";
      when X"1" => vars <= "00";
      when X"2" => vars <= "10";
      when X"3" => vars <= "11";
      when X"4" => vars <= "00";
      when X"5" => vars <= "10";
      when X"6" => vars <= "01";
      when X"7" => vars <= "10";
      when X"8" => vars <= "00";
      when X"9" => vars <= "01";
      when X"A" => vars <= "00";
      when X"B" => vars <= "10";
      when X"C" => vars <= "01";
      when X"D" => vars <= "10";
      when X"E" => vars <= "00";
      when X"F" => vars <= "01";
      when others => vars <= "00";
    end case;
  end process;
end;

```

Exercise 4.21

SystemVerilog

```

module priority_encoder2(input  logic [7:0] a,
                        output logic [2:0] y, z,
                        output logic      none);

always_comb
begin
    casez (a)
        8'b00000000: begin y = 3'd0; none = 1'b1; end
        8'b00000001: begin y = 3'd0; none = 1'b0; end
        8'b0000001?: begin y = 3'd1; none = 1'b0; end
        8'b000001??: begin y = 3'd2; none = 1'b0; end
        8'b00001??: begin y = 3'd3; none = 1'b0; end
        8'b0001??: begin y = 3'd4; none = 1'b0; end
        8'b001??: begin y = 3'd5; none = 1'b0; end
        8'b01??: begin y = 3'd6; none = 1'b0; end
        8'b1??: begin y = 3'd7; none = 1'b0; end
    endcase

    casez (a)
        8'b00000011: z = 3'b000;
        8'b00000101: z = 3'b000;
        8'b00001001: z = 3'b000;
        8'b00010001: z = 3'b000;
        8'b00100001: z = 3'b000;
        8'b01000001: z = 3'b000;
        8'b10000001: z = 3'b000;
        8'b0000011?: z = 3'b001;
        8'b0000101?: z = 3'b001;
        8'b0001001?: z = 3'b001;
        8'b0010001?: z = 3'b001;
        8'b0100001?: z = 3'b001;
        8'b1000001?: z = 3'b001;
        8'b000011??: z = 3'b010;
        8'b000101??: z = 3'b010;
        8'b001001??: z = 3'b010;
        8'b010001??: z = 3'b010;
        8'b100001??: z = 3'b010;
        8'b00011??: z = 3'b011;
        8'b00101??: z = 3'b011;
        8'b01001??: z = 3'b011;
        8'b10001??: z = 3'b011;
        8'b0011??: z = 3'b100;
        8'b0101??: z = 3'b100;
        8'b1001??: z = 3'b100;
        8'b0011??: z = 3'b101;
        8'b011??: z = 3'b101;
        8'b101??: z = 3'b101;
        8'b11??: z = 3'b110;
        default: z = 3'b000;
    endcase
end
endmodule
    
```

VHDL

```

library IEEE; use IEEE.STD_LOGIC_1164.all;

entity priority_encoder2 is
    port(a:  in  STD_LOGIC_VECTOR(7 downto 0);
         y, z: out STD_LOGIC_VECTOR(2 downto 0);
         none: out STD_LOGIC);
end;

architecture synth of priority_encoder is
begin
    process(all) begin
        case? a is
            when "00000000" => y <= "000"; none <= '1';
            when "00000001" => y <= "000"; none <= '0';
            when "0000001-" => y <= "001"; none <= '0';
            when "000001--" => y <= "010"; none <= '0';
            when "00001---" => y <= "011"; none <= '0';
            when "0001----" => y <= "100"; none <= '0';
            when "001-----" => y <= "101"; none <= '0';
            when "01-----" => y <= "110"; none <= '0';
            when "1-----" => y <= "111"; none <= '0';
            when others      => y <= "000"; none <= '0';
        end case?;
        case? a is
            when "00000011" => z <= "000";
            when "00000101" => z <= "000";
            when "00001001" => z <= "000";
            when "00001001" => z <= "000";
            when "00010001" => z <= "000";
            when "00100001" => z <= "000";
            when "01000001" => z <= "000";
            when "10000001" => z <= "000";
            when "0000011-" => z <= "001";
            when "0000101-" => z <= "001";
            when "0001001-" => z <= "001";
            when "0010001-" => z <= "001";
            when "0100001-" => z <= "001";
            when "1000001-" => z <= "001";
            when "000011--" => z <= "010";
            when "000101--" => z <= "010";
            when "001001--" => z <= "010";
            when "010001--" => z <= "010";
            when "100001--" => z <= "010";
            when "00011---" => z <= "011";
            when "00101---" => z <= "011";
            when "01001---" => z <= "011";
            when "10001---" => z <= "011";
            when "0011----" => z <= "100";
            when "0101----" => z <= "100";
            when "1001----" => z <= "100";
            when "011-----" => z <= "101";
            when "101-----" => z <= "101";
            when "11-----" => z <= "110";
            when others      => z <= "000";
        end case?;
    end process;
end;
    
```

Exercise 4.23

SystemVerilog

```

module month31days(input  logic [3:0] month,
                  output logic      y);

    always_comb
    casez (month)
    1:    y = 1'b1;
    2:    y = 1'b0;
    3:    y = 1'b1;
    4:    y = 1'b0;
    5:    y = 1'b1;
    6:    y = 1'b0;
    7:    y = 1'b1;
    8:    y = 1'b1;
    9:    y = 1'b0;
    10:   y = 1'b1;
    11:   y = 1'b0;
    12:   y = 1'b1;
    default: y = 1'b0;
    endcase
endmodule
    
```

VHDL

```

library IEEE; use IEEE.STD_LOGIC_1164.all;

entity month31days is
    port(a:  in  STD_LOGIC_VECTOR(3 downto 0);
         y:  out STD_LOGIC);
end;

architecture synth of month31days is
begin
    process(all) begin
        case a is
            when X"1" => y <= '1';
            when X"2" => y <= '0';
            when X"3" => y <= '1';
            when X"4" => y <= '0';
            when X"5" => y <= '1';
            when X"6" => y <= '0';
            when X"7" => y <= '1';
            when X"8" => y <= '1';
            when X"9" => y <= '0';
            when X"A" => y <= '1';
            when X"B" => y <= '0';
            when X"C" => y <= '1';
            when others => y <= '0';
        end case;
    end process;
end;
    
```

Exercise 4.25

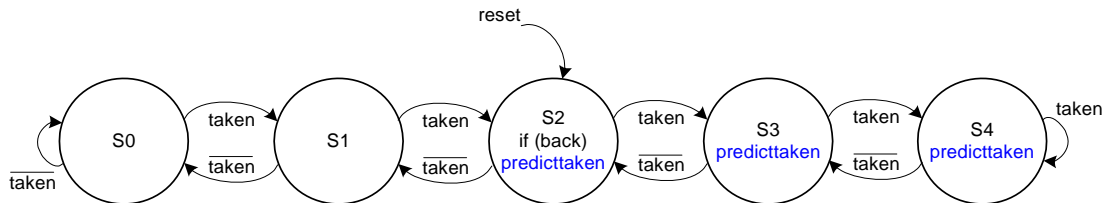

FIGURE 4.1 State transition diagram for Exercise 4.25

Exercise 4.27

SystemVerilog

```
module jkflop(input logic j, k, clk,
             output logic q);

    always @(posedge clk)
        case ({j,k})
            2'b01: q <= 1'b0;
            2'b10: q <= 1'b1;
            2'b11: q <= ~q;
        endcase
endmodule
```

VHDL

```
library IEEE; use IEEE.STD_LOGIC_1164.all;

entity jkflop is
    port(j, k, clk: in STD_LOGIC;
         q: inout STD_LOGIC);
end;

architecture synth of jkflop is
    signal jk: STD_LOGIC_VECTOR(1 downto 0);
begin
    jk <= j & k;
    process(clk) begin
        if rising_edge(clk) then
            if j = '1' and k = '0'
                then q <= '1';
            elsif j = '0' and k = '1'
                then q <= '0';
            elsif j = '1' and k = '1'
                then q <= not q;
            end if;
        end if;
    end process;
end;
```

Exercise 4.29

SystemVerilog

```

module trafficFSM(input logic clk, reset, ta, tb,
                 output logic [1:0] la, lb);

    typedef enum logic [1:0] {S0, S1, S2, S3}
        statetype;
    statetype [1:0] state, nextstate;

    parameter green = 2'b00;
    parameter yellow = 2'b01;
    parameter red = 2'b10;

    // State Register
    always_ff @(posedge clk, posedge reset)
        if (reset) state <= S0;
        else state <= nextstate;

    // Next State Logic
    always_comb
        case (state)
            S0: if (ta) nextstate = S0;
                else nextstate = S1;
            S1: nextstate = S2;
            S2: if (tb) nextstate = S2;
                else nextstate = S3;
            S3: nextstate = S0;
        endcase

    // Output Logic
    always_comb
        case (state)
            S0: {la, lb} = {green, red};
            S1: {la, lb} = {yellow, red};
            S2: {la, lb} = {red, green};
            S3: {la, lb} = {red, yellow};
        endcase
endmodule
    
```

VHDL

```

library IEEE; use IEEE.STD_LOGIC_1164.all;

entity trafficFSM is
    port(clk, reset, ta, tb: in STD_LOGIC;
         la, lb: inout STD_LOGIC_VECTOR(1 downto 0));
end;

architecture behave of trafficFSM is
    type statetype is (S0, S1, S2, S3);
    signal state, nextstate: statetype;
    signal lalb: STD_LOGIC_VECTOR(3 downto 0);
begin
    -- state register
    process(clk, reset) begin
        if reset then state <= S0;
        elsif rising_edge(clk) then
            state <= nextstate;
        end if;
    end process;

    -- next state logic
    process(all) begin
        case state is
            when S0 => if ta then
                nextstate <= S0;
            else nextstate <= S1;
            end if;
            when S1 => nextstate <= S2;
            when S2 => if tb then
                nextstate <= S2;
            else nextstate <= S3;
            end if;
            when S3 => nextstate <= S0;
            when others => nextstate <= S0;
        end case;
    end process;

    -- output logic
    la <= lalb(3 downto 2);
    lb <= lalb(1 downto 0);
    process(all) begin
        case state is
            when S0 => lalb <= "0010";
            when S1 => lalb <= "0110";
            when S2 => lalb <= "1000";
            when S3 => lalb <= "1001";
            when others => lalb <= "1010";
        end case;
    end process;
end;
    
```

Exercise 4.31

SystemVerilog

```
module fig3_42(input  logic clk, a, b, c, d,
              output logic x, y);

    logic n1, n2;
    logic areg, breg, creg, dreg;

    always_ff @(posedge clk) begin
        areg <= a;
        breg <= b;
        creg <= c;
        dreg <= d;
        x <= n2;
        y <= ~(dreg | n2);
    end

    assign n1 = areg & breg;
    assign n2 = n1 | creg;
endmodule
```

VHDL

```
library IEEE; use IEEE.STD_LOGIC_1164.all;

entity fig3_42 is
    port(clk, a, b, c, d: in  STD_LOGIC;
         x, y:                out STD_LOGIC);
end;

architecture synth of fig3_40 is
    signal n1, n2, areg, breg, creg, dreg: STD_LOGIC;
begin
    process(clk) begin
        if rising_edge(clk) then
            areg <= a;
            breg <= b;
            creg <= c;
            dreg <= d;
            x <= n2;
            y <= not (dreg or n2);
        end if;
    end process;

    n1 <= areg and breg;
    n2 <= n1 or creg;
end;
```

Exercise 4.33

SystemVerilog

```
module fig3_70(input logic clk, reset, a, b,
              output logic q);
    typedef enum logic [1:0] {S0, S1, S2} statetype;
    statetype [1:0] state, nextstate;

    // State Register
    always_ff @(posedge clk, posedge reset)
        if (reset) state <= S0;
        else state <= nextstate;

    // Next State Logic
    always_comb
        case (state)
            S0: if (a) nextstate = S1;
                else nextstate = S0;
            S1: if (b) nextstate = S2;
                else nextstate = S0;
            S2: if (a & b) nextstate = S2;
                else nextstate = S0;
            default: nextstate = S0;
        endcase

    // Output Logic
    always_comb
        case (state)
            S0: q = 0;
            S1: q = 0;
            S2: if (a & b) q = 1;
                else q = 0;
            default: q = 0;
        endcase
endmodule
```

VHDL

```
library IEEE; use IEEE.STD_LOGIC_1164.all;

entity fig3_70 is
    port(clk, reset, a, b: in STD_LOGIC;
         q: out STD_LOGIC);
end;

architecture synth of fig3_70 is
    type statetype is (S0, S1, S2);
    signal state, nextstate: statetype;
begin
    -- state register
    process(clk, reset) begin
        if reset then state <= S0;
        elsif rising_edge(clk) then
            state <= nextstate;
        end if;
    end process;

    -- next state logic
    process(all) begin
        case state is
            when S0 => if a then
                nextstate <= S1;
            else nextstate <= S0;
            end if;
            when S1 => if b then
                nextstate <= S2;
            else nextstate <= S0;
            end if;
            when S2 => if (a = '1' and b = '1') then
                nextstate <= S2;
            else nextstate <= S0;
            end if;
            when others => nextstate <= S0;
        end case;
    end process;

    -- output logic
    q <= '1' when ( (state = S2) and
                   (a = '1' and b = '1'))
        else '0';
end;
```

Exercise 4.35

SystemVerilog

```
module daughterfsm(input logic clk, reset, a,
                  output logic smile);
    typedef enum logic [1:0] {S0, S1, S2, S3, S4}
        statetype;
    statetype [2:0] state, nextstate;

    // State Register
    always_ff @(posedge clk, posedge reset)
        if (reset) state <= S0;
        else      state <= nextstate;

    // Next State Logic
    always_comb
        case (state)
            S0: if (a) nextstate = S1;
                else nextstate = S0;
            S1: if (a) nextstate = S2;
                else nextstate = S0;
            S2: if (a) nextstate = S4;
                else nextstate = S3;
            S3: if (a) nextstate = S1;
                else nextstate = S0;
            S4: if (a) nextstate = S4;
                else nextstate = S3;
            default: nextstate = S0;
        endcase

    // Output Logic
    assign smile = ((state == S3) & a) |
                  ((state == S4) & ~a);
endmodule
```

VHDL

```
library IEEE; use IEEE.STD_LOGIC_1164.all;

entity daughterfsm is
    port(clk, reset, a: in  STD_LOGIC;
         smile:      out STD_LOGIC);
end;

architecture synth of daughterfsm is
    type statetype is (S0, S1, S2, S3, S4);
    signal state, nextstate: statetype;
begin
    -- state register
    process(clk, reset) begin
        if reset then state <= S0;
        elsif rising_edge(clk) then
            state <= nextstate;
        end if;
    end process;

    -- next state logic
    process(all) begin
        case state is
            when S0 => if a then
                            nextstate <= S1;
                        else nextstate <= S0;
                        end if;
            when S1 => if a then
                            nextstate <= S2;
                        else nextstate <= S0;
                        end if;
            when S2 => if a then
                            nextstate <= S4;
                        else nextstate <= S3;
                        end if;
            when S3 => if a then
                            nextstate <= S1;
                        else nextstate <= S0;
                        end if;
            when S4 => if a then
                            nextstate <= S4;
                        else nextstate <= S3;
                        end if;
            when others => nextstate <= S0;
        end case;
    end process;

    -- output logic
    smile <= '1' when ( ((state = S3) and (a = '1')) or
                       ((state = S4) and (a = '0')) )
              else '0';
end;
```

Exercise 4.37

SystemVerilog

```

module ex4_37(input  logic      clk, reset,
              output logic [2:0] q);
  typedef enum logic [2:0] {S0 = 3'b000,
                           S1 = 3'b001,
                           S2 = 3'b011,
                           S3 = 3'b010,
                           S4 = 3'b110,
                           S5 = 3'b111,
                           S6 = 3'b101,
                           S7 = 3'b100}
    statetype;

  statetype [2:0] state, nextstate;

  // State Register
  always_ff @(posedge clk, posedge reset)
    if (reset) state <= S0;
    else      state <= nextstate;

  // Next State Logic
  always_comb
    case (state)
      S0: nextstate = S1;
      S1: nextstate = S2;
      S2: nextstate = S3;
      S3: nextstate = S4;
      S4: nextstate = S5;
      S5: nextstate = S6;
      S6: nextstate = S7;
      S7: nextstate = S0;
    endcase

  // Output Logic
  assign q = state;
endmodule

```

VHDL

```

library IEEE; use IEEE.STD_LOGIC_1164.all;

entity ex4_37 is
  port(clk:  in  STD_LOGIC;
       reset: in  STD_LOGIC;
       q:    out STD_LOGIC_VECTOR(2 downto 0));
end;

architecture synth of ex4_37 is
  signal state:      STD_LOGIC_VECTOR(2 downto 0);
  signal nextstate: STD_LOGIC_VECTOR(2 downto 0);
begin
  -- state register
  process(clk, reset) begin
    if reset then state <= "000";
    elsif rising_edge(clk) then
      state <= nextstate;
    end if;
  end process;

  -- next state logic
  process(all) begin
    case state is
      when "000" => nextstate <= "001";
      when "001" => nextstate <= "011";
      when "011" => nextstate <= "010";
      when "010" => nextstate <= "110";
      when "110" => nextstate <= "111";
      when "111" => nextstate <= "101";
      when "101" => nextstate <= "100";
      when "100" => nextstate <= "000";
      when others => nextstate <= "000";
    end case;
  end process;

  -- output logic
  q <= state;
end;

```

Exercise 4.39

Option 1**SystemVerilog**

```

module ex4_39(input logic clk, reset, a, b,
             output logic z);
    typedef enum logic [1:0] {S0, S1, S2, S3}
        statetype;
    statetype [1:0] state, nextstate;

    // State Register
    always_ff @(posedge clk, posedge reset)
        if (reset) state <= S0;
        else state <= nextstate;

    // Next State Logic
    always_comb
        case (state)
            S0: case ({b,a})
                2'b00: nextstate = S0;
                2'b01: nextstate = S3;
                2'b10: nextstate = S0;
                2'b11: nextstate = S1;
            endcase
            S1: case ({b,a})
                2'b00: nextstate = S0;
                2'b01: nextstate = S3;
                2'b10: nextstate = S2;
                2'b11: nextstate = S1;
            endcase
            S2: case ({b,a})
                2'b00: nextstate = S0;
                2'b01: nextstate = S3;
                2'b10: nextstate = S2;
                2'b11: nextstate = S1;
            endcase
            S3: case ({b,a})
                2'b00: nextstate = S0;
                2'b01: nextstate = S3;
                2'b10: nextstate = S2;
                2'b11: nextstate = S1;
            endcase
            default: nextstate = S0;
        endcase

    // Output Logic
    always_comb
        case (state)
            S0: z = a & b;
            S1: z = a | b;
            S2: z = a & b;
            S3: z = a | b;
            default: z = 1'b0;
        endcase
    endmodule

```

VHDL

```

library IEEE; use IEEE.STD_LOGIC_1164.all;

entity ex4_39 is
    port(clk: in STD_LOGIC;
         reset: in STD_LOGIC;
         a, b: in STD_LOGIC;
         z: out STD_LOGIC);
end;

architecture synth of ex4_39 is
    type statetype is (S0, S1, S2, S3);
    signal state, nextstate: statetype;
    signal ba: STD_LOGIC_VECTOR(1 downto 0);
begin
    -- state register
    process(clk, reset) begin
        if reset then state <= S0;
        elsif rising_edge(clk) then
            state <= nextstate;
        end if;
    end process;

    -- next state logic
    ba <= b & a;
    process(all) begin
        case state is
            when S0 =>
                case (ba) is
                    when "00" => nextstate <= S0;
                    when "01" => nextstate <= S3;
                    when "10" => nextstate <= S0;
                    when "11" => nextstate <= S1;
                    when others => nextstate <= S0;
                end case;
            when S1 =>
                case (ba) is
                    when "00" => nextstate <= S0;
                    when "01" => nextstate <= S3;
                    when "10" => nextstate <= S2;
                    when "11" => nextstate <= S1;
                    when others => nextstate <= S0;
                end case;
            when S2 =>
                case (ba) is
                    when "00" => nextstate <= S0;
                    when "01" => nextstate <= S3;
                    when "10" => nextstate <= S2;
                    when "11" => nextstate <= S1;
                    when others => nextstate <= S0;
                end case;
            when S3 =>
                case (ba) is
                    when "00" => nextstate <= S0;
                    when "01" => nextstate <= S3;
                    when "10" => nextstate <= S2;
                    when "11" => nextstate <= S1;
                    when others => nextstate <= S0;
                end case;
            when others => nextstate <= S0;
        end case;
    end process;
end process;

```

(continued from previous page)

VHDL

```
-- output logic
process(all) begin
  case state is
    when S0 => if (a = '1' and b = '1')
                then z <= '1';
                else z <= '0';
              end if;
    when S1 => if (a = '1' or b = '1')
                then z <= '1';
                else z <= '0';
              end if;
    when S2 => if (a = '1' and b = '1')
                then z <= '1';
                else z <= '0';
              end if;
    when S3 => if (a = '1' or b = '1')
                then z <= '1';
                else z <= '0';
              end if;
    when others => z <= '0';
  end case;
end process;
end;
```

Option 2

SystemVerilog

```
module ex4_37(input logic clk, a, b,
             output logic z);

  logic aprev;

  // State Register
  always_ff @(posedge clk)
    aprev <= a;

  assign z = b ? (aprev | a) : (aprev & a);
endmodule
```

VHDL

```
library IEEE; use IEEE.STD_LOGIC_1164.all;

entity ex4_37 is
  port(clk: in STD_LOGIC;
        a, b: in STD_LOGIC;
        z: out STD_LOGIC);
end;

architecture synth of ex4_37 is
  signal aprev, nland, n2or: STD_LOGIC;
begin
  -- state register
  process(clk) begin
    if rising_edge(clk) then
      aprev <= a;
    end if;
  end process;

  z <= (a or aprev) when b = '1' else
      (a and aprev);
end;
```

Exercise 4.41

SystemVerilog

```
module ex4_41(input logic clk, start, a,
             output logic q);
    typedef enum logic [1:0] {S0, S1, S2, S3}
        statetype;
    statetype [1:0] state, nextstate;

    // State Register
    always_ff @(posedge clk, posedge start)
        if (start) state <= S0;
        else state <= nextstate;

    // Next State Logic
    always_comb
        case (state)
            S0: if (a) nextstate = S1;
                else nextstate = S0;
            S1: if (a) nextstate = S2;
                else nextstate = S3;
            S2: if (a) nextstate = S2;
                else nextstate = S3;
            S3: if (a) nextstate = S2;
                else nextstate = S3;
        endcase

    // Output Logic
    assign q = state[0];
endmodule
```

VHDL

```
library IEEE; use IEEE.STD_LOGIC_1164.all;

entity ex4_41 is
    port(clk, start, a: in STD_LOGIC;
         q: out STD_LOGIC);
end;

architecture synth of ex4_41 is
    type statetype is (S0, S1, S2, S3);
    signal state, nextstate: statetype;
begin
    -- state register
    process(clk, start) begin
        if start then state <= S0;
        elsif rising_edge(clk) then
            state <= nextstate;
        end if;
    end process;

    -- next state logic
    process(all) begin
        case state is
            when S0 => if a then
                        nextstate <= S1;
                    else nextstate <= S0;
                    end if;
            when S1 => if a then
                        nextstate <= S2;
                    else nextstate <= S3;
                    end if;
            when S2 => if a then
                        nextstate <= S2;
                    else nextstate <= S3;
                    end if;
            when S3 => if a then
                        nextstate <= S2;
                    else nextstate <= S3;
                    end if;
            when others => nextstate <= S0;
        end case;
    end process;

    -- output logic
    q <= '1' when ((state = S1) or (state = S3))
        else '0';
end;
```

Exercise 4.43

SystemVerilog

```
module ex4_43(input clk, reset, a,
             output q);
    typedef enum logic [1:0] {S0, S1, S2} statetype;
    statetype [1:0] state, nextstate;

    // State Register
    always_ff @(posedge clk, posedge reset)
        if (reset) state <= S0;
        else state <= nextstate;

    // Next State Logic
    always_comb
        case (state)
            S0: if (a) nextstate = S1;
                else nextstate = S0;
            S1: if (a) nextstate = S2;
                else nextstate = S0;
            S2: if (a) nextstate = S2;
                else nextstate = S0;
            default: nextstate = S0;
        endcase

    // Output Logic
    assign q = state[1];
endmodule
```

VHDL

```
library IEEE; use IEEE.STD_LOGIC_1164.all;

entity ex4_43 is
    port(clk, reset, a: in STD_LOGIC;
         q: out STD_LOGIC);
end;

architecture synth of ex4_43 is
    type statetype is (S0, S1, S2);
    signal state, nextstate: statetype;
begin
    -- state register
    process(clk, reset) begin
        if reset then state <= S0;
        elsif rising_edge(clk) then
            state <= nextstate;
        end if;
    end process;

    -- next state logic
    process(all) begin
        case state is
            when S0 => if a then
                            nextstate <= S1;
                        else nextstate <= S0;
                        end if;
            when S1 => if a then
                            nextstate <= S2;
                        else nextstate <= S0;
                        end if;
            when S2 => if a then
                            nextstate <= S2;
                        else nextstate <= S0;
                        end if;
            when others => nextstate <= S0;
        end case;
    end process;

    -- output logic
    q <= '1' when (state = S2) else '0';
end;
```

Exercise 4.45

SystemVerilog

```
module ex4_45(input logic clk, c,
             input logic [1:0] a, b,
             output logic [1:0] s);

    logic [1:0] areg, breg;
    logic creg;
    logic [1:0] sum;
    logic cout;

    always_ff @(posedge clk)
        {areg, breg, creg, s} <= {a, b, c, sum};

    fulladder fulladd1(areg[0], breg[0], creg,
                     sum[0], cout);
    fulladder fulladd2(areg[1], breg[1], cout,
                     sum[1], );
endmodule
```

VHDL

```
library IEEE; use IEEE.STD_LOGIC_1164.all;

entity ex4_45 is
    port(clk, c: in STD_LOGIC;
         a, b: in STD_LOGIC_VECTOR(1 downto 0);
         s: out STD_LOGIC_VECTOR(1 downto 0));
end;

architecture synth of ex4_45 is
    component fulladder is
        port(a, b, cin: in STD_LOGIC;
             s, cout: out STD_LOGIC);
    end component;
    signal creg: STD_LOGIC;
    signal areg, breg, cout: STD_LOGIC_VECTOR(1 downto 0);
    signal sum: STD_LOGIC_VECTOR(1 downto 0);
begin
    process(clk) begin
        if rising_edge(clk) then
            areg <= a;
            breg <= b;
            creg <= c;
            s <= sum;
        end if;
    end process;

    fulladd1: fulladder
        port map(areg(0), breg(0), creg, sum(0), cout(0));
    fulladd2: fulladder
        port map(areg(1), breg(1), cout, sum(1),
                cout(1));
end;
```

Exercise 4.47

SystemVerilog

```
module syncbad(input logic clk,  
              input logic d,  
              output logic q);  
  
  logic n1;  
  
  always_ff @(posedge clk)  
  begin  
    q <= n1; // nonblocking  
    n1 <= d; // nonblocking  
  end  
endmodule
```

VHDL

```
library IEEE; use IEEE.STD_LOGIC_1164.all;  
  
entity syncbad is  
  port(clk: in STD_LOGIC;  
        d: in STD_LOGIC;  
        q: out STD_LOGIC);  
end;  
  
architecture bad of syncbad is  
begin  
  process(clk)  
    variable n1: STD_LOGIC;  
  begin  
    if rising_edge(clk) then  
      q <= n1; -- nonblocking  
      n1 <= d; -- nonblocking  
    end if;  
  end process;  
end;
```

Exercise 4.49

They do not have the same function.

code1

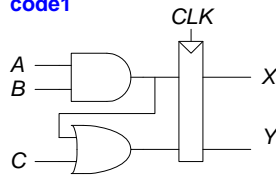

code2

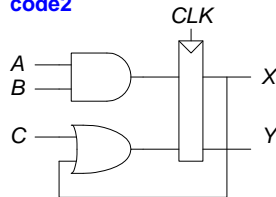

Exercise 4.51

It is necessary to write

```
q <= '1' when state = S0 else '0';
```

rather than simply

```
q <= (state = S0);
```

because the result of the comparison (`state = S0`) is of type `Boolean` (true and false) and `q` must be assigned a value of type `STD_LOGIC` ('1' and '0').

Question 4.1

SystemVerilog

```
assign result = sel ? data : 32'b0;
```

VHDL

```
result <= data when sel = '1' else X"00000000";
```

Question 4.3

The SystemVerilog statement performs the bit-wise AND of the 16 least significant bits of `data` with `0xC820`. It then ORs these 16 bits to produce the 1-bit result.

CHAPTER 5

Exercise 5.1

(a) From Equation 5.1, we find the 64-bit ripple-carry adder delay to be:

$$t_{\text{ripple}} = Nt_{\text{FA}} = 64(450 \text{ ps}) = 28.8 \text{ ns}$$

(b) From Equation 5.6, we find the 64-bit carry-lookahead adder delay to be:

$$t_{\text{CLA}} = t_{\text{pg}} + t_{\text{pg_block}} + \left(\frac{N}{k} - 1\right)t_{\text{AND_OR}} + kt_{\text{FA}}$$

$$t_{\text{CLA}} = \left[150 + (6 \times 150) + \left(\frac{64}{4} - 1\right)300 + (4 \times 450)\right] = 7.35 \text{ ns}$$

(Note: the actual delay is only 7.2 ns because the first AND_OR gate only has a 150 ps delay.)

(c) From Equation 5.11, we find the 64-bit prefix adder delay to be:

$$t_{\text{PA}} = t_{\text{pg}} + \log_2 N(t_{\text{pg_prefix}}) + t_{\text{XOR}}$$

$$t_{\text{PA}} = [150 + 6(300) + 150] = 2.1 \text{ ns}$$

Exercise 5.3

A designer might choose to use a ripple-carry adder instead of a carry-lookahead adder if chip area is the critical resource and delay is not the critical constraint.

Exercise 5.5

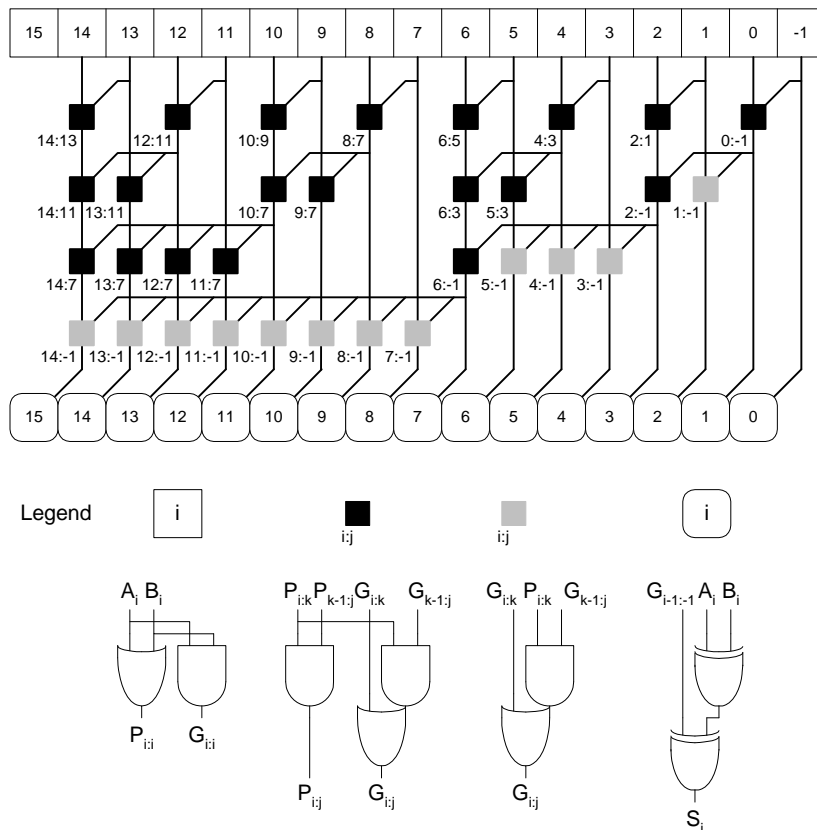

FIGURE 5.1 16-bit prefix adder with “gray cells”

Exercise 5.7

(a) We show an 8-bit priority circuit in Figure 5.2. In the figure $X_7 = \bar{A}_7$, $X_{7:6} = \bar{A}_7\bar{A}_6$, $X_{7:5} = \bar{A}_7\bar{A}_6\bar{A}_5$, and so on. The priority encoder’s delay is $\log_2 N$ 2-input AND gates followed by a final row of 2-input AND gates. The final stage is an $(N/2)$ -input OR gate. Thus, in general, the delay of an N -input priority encoder is:

$$t_{pd_priority} = (\log_2 N + 1)t_{pd_AND2} + t_{pd_ORN/2}$$

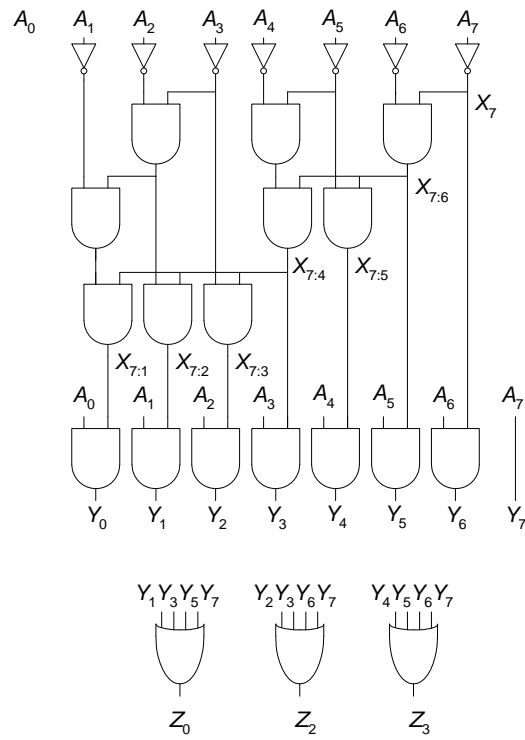

FIGURE 5.2 8-input priority encoder

SystemVerilog

```
module priorityckt(input logic [7:0] a,
                  output logic [2:0] z);
    logic [7:0] y;
    logic x7, x76, x75, x74, x73, x72, x71;
    logic x32, x54, x31;
    logic [7:0] abar;

    // row of inverters
    assign abar = ~a;

    // first row of AND gates
    assign x7 = abar[7];
    assign x76 = abar[6] & x7;
    assign x54 = abar[4] & abar[5];
    assign x32 = abar[2] & abar[3];

    // second row of AND gates
    assign x75 = abar[5] & x76;
    assign x74 = x54 & x76;
    assign x31 = abar[1] & x32;

    // third row of AND gates
    assign x73 = abar[3] & x74;
    assign x72 = x32 & x74;
    assign x71 = x31 & x74;

    // fourth row of AND gates
    assign y = {a[7], a[6] & x7, a[5] & x76,
               a[4] & x75, a[3] & x74, a[2] & x73,
               a[1] & x72, a[0] & x71};

    // row of OR gates
    assign z = { |{y[7:4]},
               |{y[7:6], y[3:2]},
               |{y[1], y[3], y[5], y[7]} };
endmodule
```

VHDL

```
library IEEE; use IEEE.STD_LOGIC_1164.all;

entity priorityckt is
    port(a: in STD_LOGIC_VECTOR(7 downto 0);
         z: out STD_LOGIC_VECTOR(2 downto 0));
end;

architecture synth of priorityckt is
    signal y, abar: STD_LOGIC_VECTOR(7 downto 0);
    signal x7, x76, x75, x74, x73, x72, x71,
           x32, x54, x31: STD_LOGIC;
begin
    -- row of inverters
    abar <= not a;

    -- first row of AND gates
    x7 <= abar(7);
    x76 <= abar(6) and x7;
    x54 <= abar(4) and abar(5);
    x32 <= abar(2) and abar(3);

    -- second row of AND gates
    x75 <= abar(5) and x76;
    x74 <= x54 and x76;
    x31 <= abar(1) and x32;

    -- third row of AND gates
    x73 <= abar(3) and x74;
    x72 <= x32 and x74;
    x71 <= x31 and x74;

    -- fourth row of AND gates
    y <= (a(7) & (a(6) and x7) & (a(5) and x76) &
          (a(4) and x75) & (a(3) and x74) & (a(2) and
          x73) &
          (a(1) and x72) & (a(0) and x71));

    -- row of OR gates
    z <= ( (y(7) or y(6) or y(5) or y(4)) &
          (y(7) or y(6) or y(3) or y(2)) &
          (y(1) or y(3) or y(5) or y(7)) );
end;
```

Exercise 5.9

SystemVerilog

```
module alu32(input logic [31:0] A, B,  
            input logic [2:0] F,  
            output logic [31:0] Y);  
  
    logic [31:0] S, Bout;  
  
    assign Bout = F[2] ? ~B : B;  
    assign S = A + Bout + F[2];  
  
    always_comb  
        case (F[1:0])  
            2'b00: Y <= A & Bout;  
            2'b01: Y <= A | Bout;  
            2'b10: Y <= S;  
            2'b11: Y <= S[31];  
        endcase  
  
endmodule
```

VHDL

```
library IEEE;  
use IEEE.STD_LOGIC_1164.all;  
use IEEE.std_logic_arith.all;  
use ieee.std_logic_unsigned.all;  
  
entity alu32 is  
    port(A, B: in STD_LOGIC_VECTOR(31 downto 0);  
         F: in STD_LOGIC_VECTOR(2 downto 0);  
         Y: out STD_LOGIC_VECTOR(31 downto 0));  
end;  
  
architecture synth of alu32 is  
    signal S, Bout: STD_LOGIC_VECTOR(31 downto 0);  
begin  
    Bout <= (not B) when (F(2) = '1') else B;  
    S <= A + Bout + F(2);  
  
    process(all) begin  
        case F(1 downto 0) is  
            when "00" => Y <= A and Bout;  
            when "01" => Y <= A or Bout;  
            when "10" => Y <= S;  
            when "11" => Y <=  
                ("00000000000000000000000000000000" & S(31));  
            when others => Y <= X"00000000";  
        end case;  
    end process;  
end;
```

Exercise 5.11

SystemVerilog

```

module alu32(input logic [31:0] A, B,
            input logic [2:0] F,
            output logic [31:0] Y,
            output logic Zero, Overflow);
    logic [31:0] S, Bout;

    assign Bout = F[2] ? ~B : B;
    assign S = A + Bout + F[2];

    always_comb
    case (F[1:0])
        2'b00: Y <= A & Bout;
        2'b01: Y <= A | Bout;
        2'b10: Y <= S;
        2'b11: Y <= S[31];
    endcase

    assign Zero = (Y == 32'b0);

    always_comb
    case (F[2:1])
        2'b01: Overflow <= A[31] & B[31] & ~S[31] |
                    ~A[31] & ~B[31] & S[31];
        2'b11: Overflow <= ~A[31] & B[31] & S[31] |
                    A[31] & ~B[31] & ~S[31];
        default: Overflow <= 1'b0;
    endcase
endmodule
    
```

VHDL

```

library IEEE;
use IEEE.STD_LOGIC_1164.all;
use IEEE.std_logic_arith.all;
use ieee.std_logic_unsigned.all;

entity alu32 is
    port(A, B: in STD_LOGIC_VECTOR(31 downto 0);
          F: in STD_LOGIC_VECTOR(2 downto 0);
          Y: inout STD_LOGIC_VECTOR(31 downto 0);
          Overflow: out STD_LOGIC;
          Zero: out STD_LOGIC);
end;

architecture synth of alu32 is
    signal S, Bout: STD_LOGIC_VECTOR(31 downto 0);
begin
    Bout <= (not B) when (F(2) = '1') else B;
    S <= A + Bout + F(2);

    -- alu function
    process(all) begin
        case F(1 downto 0) is
            when "00" => Y <= A and Bout;
            when "01" => Y <= A or Bout;
            when "10" => Y <= S;
            when "11" => Y <=
                ("00000000000000000000000000000000" & S(31));
            when others => Y <= X"00000000";
        end case;
    end process;

    Zero <= '1' when (Y = X"00000000") else '0';

    -- overflow circuit
    process(all) begin
        case F(2 downto 1) is
            when "01" => Overflow <=
                (A(31) and B(31) and (not (S(31)))) or
                ((not A(31)) and (not B(31)) and S(31));
            when "11" => Overflow <=
                ((not A(31)) and B(31) and S(31)) or
                (A(31) and (not B(31)) and (not S(31)));
            when others => Overflow <= '0';
        end case;
    end process;
end;
    
```

Exercise 5.13

A 2-bit left shifter creates the output by appending two zeros to the least significant bits of the input and dropping the two most significant bits.

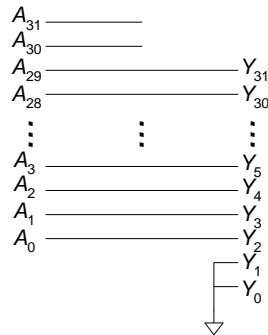

FIGURE 5.3 2-bit left shifter, 32-bit input and output

2-bit Left Shifter

SystemVerilog

```
module leftshift2_32(input  logic [31:0] a,
                   output logic [31:0] y);
    assign y = {a[29:0], 2'b0};
endmodule
```

VHDL

```
library IEEE;
use IEEE.STD_LOGIC_1164.all;

entity leftshift2_32 is
    port(a: in  STD_LOGIC_VECTOR(31 downto 0);
         y: out STD_LOGIC_VECTOR(31 downto 0));
end;

architecture synth of leftshift2_32 is
begin
    y <= a(29 downto 0) & "00";
end;
```

Exercise 5.15

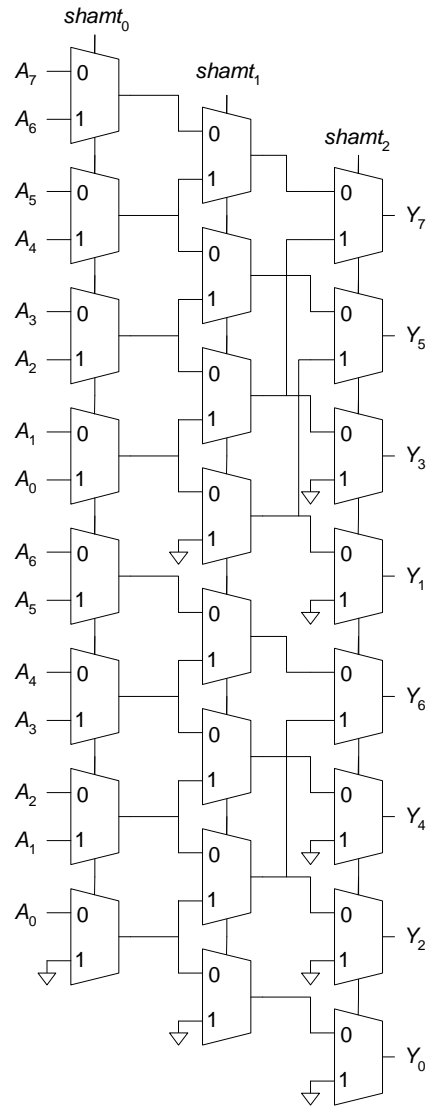

FIGURE 5.4 8-bit left shifter using 24 2:1 multiplexers

Exercise 5.17

(a) $B = 0$, $C = A$, $k = shamt$

(b) $B = A_{N-1}$ (the most significant bit of A), repeated N times to fill all N bits of B

(c) $B = A, C = 0, k = N - shamt$

(d) $B = A, C = A, k = shamt$

(e) $B = A, C = A, k = N - shamt$

Exercise 5.19

$$t_{pd_DIV4} = 4(4t_{FA} + t_{MUX}) = 16t_{FA} + 4t_{MUX}$$

$$t_{pd_DIVN} = N^2t_{FA} + Nt_{MUX}$$

Exercise 5.21

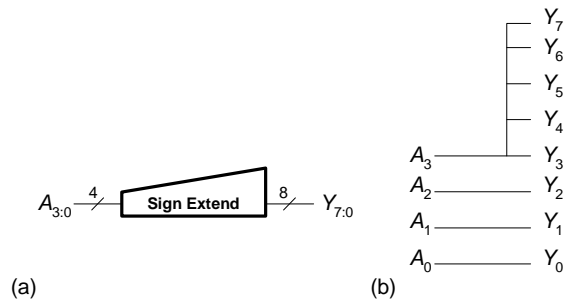

FIGURE 5.5 Sign extension unit (a) symbol, (b) underlying hardware

SystemVerilog

```
module signext4_8(input logic [3:0] a,
                 output logic [7:0] y);
    assign y = { {4{a[3]}}, a };
endmodule
```

VHDL

```
library IEEE;
use IEEE.STD_LOGIC_1164.all;

entity signext4_8 is
    port(a: in STD_LOGIC_VECTOR(3 downto 0);
         y: out STD_LOGIC_VECTOR(7 downto 0));
end;

architecture synth of signext4_8 is
begin
```

Exercise 5.23

$$\begin{array}{r}
 100.110 \\
 1100 \overline{) 111001.000} \\
 \underline{-1100} \\
 001001 \\
 \underline{-1100} \\
 1100 \\
 \underline{-1100} \\
 0
 \end{array}$$

Exercise 5.25

- (a) 1000 1101 . 1001 0000 = 0x8D90
- (b) 0010 1010 . 0101 0000 = 0x2A50
- (c) 1001 0001 . 0010 1000 = 0x9128

Exercise 5.27

- (a) 1111 0010 . 0111 0000 = 0xF270
- (b) 0010 1010 . 0101 0000 = 0x2A50
- (c) 1110 1110 . 1101 1000 = 0xEEED8

Exercise 5.29

- (a) $-1101.1001 = -1.1011001 \times 2^3$
 Thus, the biased exponent = $127 + 3 = 130 = 1000\ 0010_2$
 In IEEE 754 single-precision floating-point format:
 1 1000 0010 101 1001 0000 0000 0000 0000 = **0xC1590000**

- (b) $101010.0101 = 1.010100101 \times 2^5$
 Thus, the biased exponent = $127 + 5 = 132 = 1000\ 0100_2$
 In IEEE 754 single-precision floating-point format:
 0 1000 0100 010 1001 0100 0000 0000 0000 = **0x42294000**

- (c) $-10001.00101 = -1.000100101 \times 2^4$
 Thus, the biased exponent = $127 + 4 = 131 = 1000\ 0011_2$
 In IEEE 754 single-precision floating-point format:
 1 1000 0011 000 1001 0100 0000 0000 0000 = **0xC1894000**

Exercise 5.31

- (a) 5.5
 (b) $-0000.0001_2 = -0.0625$
 (c) -8

Exercise 5.33

When adding two floating point numbers, the number with the smaller exponent is shifted to preserve the most significant bits. For example, suppose we were adding the two floating point numbers 1.0×2^0 and 1.0×2^{-27} . We make the two exponents equal by shifting the second number right by 27 bits. Because the mantissa is limited to 24 bits, the second number ($1.000\ 0000\ 0000\ 0000\ 0000 \times 2^{-27}$) becomes $0.000\ 0000\ 0000\ 0000\ 0000 \times 2^0$, because the 1 is shifted off to the right. If we had shifted the number with the larger exponent (1.0×2^0) to the left, we would have shifted off the more significant bits (on the order of 2^0 instead of on the order of 2^{-27}).

Exercise 5.35

- (a)
 $0xC0D20004 = 1\ 1000\ 0001\ 101\ 0010\ 0000\ 0000\ 0000\ 0100$
 $= -1.101\ 0010\ 0000\ 0000\ 0000\ 01 \times 2^2$
 $0x72407020 = 0\ 1110\ 0100\ 100\ 0000\ 0111\ 0000\ 0010\ 0000$
 $= 1.100\ 0000\ 0111\ 0000\ 001 \times 2^{101}$

When adding these two numbers together, $0xC0D20004$ becomes:
 0×2^{101} because all of the significant bits shift off the right when making the exponents equal. Thus, the result of the addition is simply the second number:

$0x72407020$

- (b)
 $0xC0D20004 = 1\ 1000\ 0001\ 101\ 0010\ 0000\ 0000\ 0000\ 0100$
 $= -1.101\ 0010\ 0000\ 0000\ 0000\ 01 \times 2^2$
 $0x40DC0004 = 0\ 1000\ 0001\ 101\ 1100\ 0000\ 0000\ 0000\ 0100$
 $= 1.101\ 1100\ 0000\ 0000\ 0000\ 01 \times 2^2$

$1.101\ 1100\ 0000\ 0000\ 0000\ 01 \times 2^2$

$$\begin{aligned}
 & - 1.101\ 0010\ 0000\ 0000\ 0000\ 01 \times 2^2 \\
 = & 0.000\ 1010 \qquad \qquad \qquad \times 2^2 \\
 = & 1.010 \times 2^{-2} \\
 \\
 = & 0\ 0111\ 1101\ 010\ 0000\ 0000\ 0000\ 0000\ 0000 \\
 = & 0x3EA00000
 \end{aligned}$$

(c)

$$\begin{aligned}
 0x5FBE4000 &= 0\ 1011\ 1111\ 011\ 1110\ 0100\ 0000\ 0000\ 0000\ 0000 \\
 &= 1.011\ 1110\ 01 \times 2^{64} \\
 0x3FF80000 &= 0\ 0111\ 1111\ 111\ 1000\ 0000\ 0000\ 0000\ 0000 \\
 &= 1.111\ 1 \times 2^0 \\
 0xDFDE4000 &= 1\ 1011\ 1111\ 101\ 1110\ 0100\ 0000\ 0000\ 0000\ 0000 \\
 &= - 1.101\ 1110\ 01 \times 2^{64}
 \end{aligned}$$

Thus, $(1.011\ 1110\ 01 \times 2^{64} + 1.111\ 1 \times 2^0) = 1.011\ 1110\ 01 \times 2^{64}$

And, $(1.011\ 1110\ 01 \times 2^{64} + 1.111\ 1 \times 2^0) - 1.101\ 1110\ 01 \times 2^{64} =$
 $- 0.01 \times 2^{64} = -1.0 \times 2^{64} =$
 $= 1\ 1011\ 1101\ 000\ 0000\ 0000\ 0000\ 0000\ 0000$
 $= \mathbf{0xDE800000}$

This is counterintuitive because the second number (0x3FF80000) does not affect the result because its order of magnitude is less than 2^{23} of the other numbers. This second number's significant bits are shifted off when the exponents are made equal.

Exercise 5.37

(a) $2(2^{31} - 1 - 2^{23}) = 2^{32} - 2 - 2^{24} = 4,278,190,078$

(b) $2(2^{31} - 1) = 2^{32} - 2 = 4,294,967,294$

(c) $\pm\infty$ and NaN are given special representations because they are often used in calculations and in representing results. These values also give useful information to the user as return values, instead of returning garbage upon overflow, underflow, or divide by zero.

Exercise 5.39

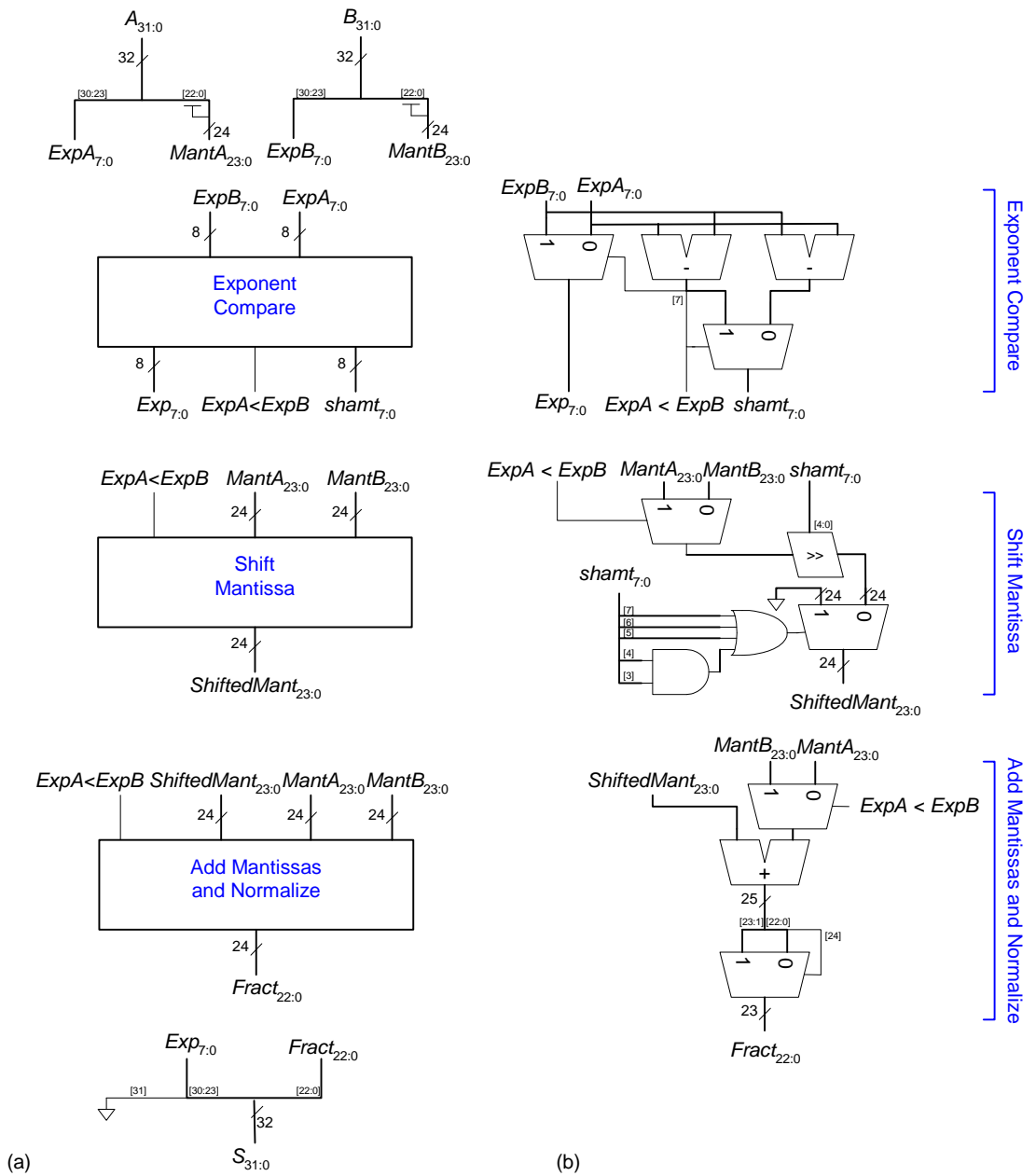

FIGURE 5.6 Floating-point adder hardware: (a) block diagram, (b) underlying hardware

SystemVerilog

```

module fpadd(input logic [31:0] a, b,
            output logic [31:0] s);

    logic [7:0] expa, expb, exp_pre, exp, shamt;
    logic alessb;
    logic [23:0] manta, mantb, shmant;
    logic [22:0] fract;

    assign {expa, manta} = {a[30:23], 1'b1, a[22:0]};
    assign {expb, mantb} = {b[30:23], 1'b1, b[22:0]};
    assign s = {1'b0, exp, fract};

    expcomp expcomp1(expa, expb, alessb, exp_pre,
                    shamt);
    shiftmant shiftmant1(alessb, manta, mantb,
                        shamt, shmant);
    addmant addmant1(alessb, manta, mantb,
                    shmant, exp_pre, fract, exp);

endmodule
    
```

VHDL

```

library IEEE; use IEEE.STD_LOGIC_1164.all;
use IEEE.STD_LOGIC_UNSIGNED.all;
use IEEE.STD_LOGIC_ARITH.all;

entity fpadd is
    port(a, b: in STD_LOGIC_VECTOR(31 downto 0);
         s: out STD_LOGIC_VECTOR(31 downto 0));
end;

architecture synth of fpadd is
    component expcomp
        port(expa, expb: in STD_LOGIC_VECTOR(7 downto 0);
             alessb: inout STD_LOGIC;
             exp,shamt: out STD_LOGIC_VECTOR(7 downto 0));
    end component;

    component shiftmant
        port(alessb: in STD_LOGIC;
             manta: in STD_LOGIC_VECTOR(23 downto 0);
             mantb: in STD_LOGIC_VECTOR(23 downto 0);
             shamt: in STD_LOGIC_VECTOR(7 downto 0);
             shmant: out STD_LOGIC_VECTOR(23 downto 0));
    end component;

    component addmant
        port(alessb: in STD_LOGIC;
             manta: in STD_LOGIC_VECTOR(23 downto 0);
             mantb: in STD_LOGIC_VECTOR(23 downto 0);
             shmant: in STD_LOGIC_VECTOR(23 downto 0);
             exp_pre: in STD_LOGIC_VECTOR(7 downto 0);
             fract: out STD_LOGIC_VECTOR(22 downto 0);
             exp: out STD_LOGIC_VECTOR(7 downto 0));
    end component;

    signal expa, expb: STD_LOGIC_VECTOR(7 downto 0);
    signal exp_pre, exp: STD_LOGIC_VECTOR(7 downto 0);
    signal shamt: STD_LOGIC_VECTOR(7 downto 0);
    signal alessb: STD_LOGIC;
    signal manta: STD_LOGIC_VECTOR(23 downto 0);
    signal mantb: STD_LOGIC_VECTOR(23 downto 0);
    signal shmant: STD_LOGIC_VECTOR(23 downto 0);
    signal fract: STD_LOGIC_VECTOR(22 downto 0);

begin

    expa <= a(30 downto 23);
    manta <= '1' & a(22 downto 0);
    expb <= b(30 downto 23);
    mantb <= '1' & b(22 downto 0);

    s <= '0' & exp & fract;

    expcomp1: expcomp
        port map(expa, expb, alessb, exp_pre, shamt);
    shiftmant1: shiftmant
        port map(alessb, manta, mantb, shamt, shmant);
    addmant1: addmant
        port map(alessb, manta, mantb, shmant,
                exp_pre, fract, exp);

end;
    
```

(continued from previous page)

SystemVerilog

```
module expcomp(input  logic [7:0] expa, expb,
               output logic   alessb,
               output logic [7:0] exp, shamt);
    logic [7:0] aminusb, bminusa;

    assign aminusb = expa - expb;
    assign bminusa = expb - expa;
    assign alessb  = aminusb[7];

    always_comb
    if (alessb) begin
        exp = expb;
        shamt = bminusa;
    end
    else begin
        exp = expa;
        shamt = aminusb;
    end
endmodule
```

VHDL

```
library IEEE; use IEEE.STD_LOGIC_1164.all;
use IEEE.STD_LOGIC_UNSIGNED.all;
use IEEE.STD_LOGIC_ARITH.all;

entity expcomp is
    port(expa, expb: in  STD_LOGIC_VECTOR(7 downto 0);
         alessb:   inout STD_LOGIC;
         exp,shamt: out STD_LOGIC_VECTOR(7 downto 0));
end;

architecture synth of expcomp is
    signal aminusb: STD_LOGIC_VECTOR(7 downto 0);
    signal bminusa: STD_LOGIC_VECTOR(7 downto 0);
begin
    aminusb <= expa - expb;
    bminusa <= expb - expa;
    alessb <= aminusb(7);

    exp <= expb when alessb = '1' else expa;
    shamt <= bminusa when alessb = '1' else aminusb;

end;
```

(continued on next page)

(continued from previous page)

SystemVerilog

```

module shiftmant(input  logic alessb,
                input  logic [23:0] manta, mantb,
                input  logic [7:0] shamt,
                output logic [23:0] shmant);

    logic [23:0] shiftedval;

    assign shiftedval = alessb ?
        (manta >> shamt) : (mantb >> shamt);

    always_comb
        if (shamt[7] | shamt[6] | shamt[5] |
            shamt[4] & shamt[3]))
            shmant = 24'b0;
        else
            shmant = shiftedval;

endmodule

module addmant(input  logic alessb,
               input  logic [23:0] manta,
               input  logic [7:0] mantb, shmant,
               input  logic [7:0] exp_pre,
               output logic [22:0] fract,
               output logic [7:0] exp);

    logic [24:0] addressult;
    logic [23:0] addval;

    assign addval = alessb ? mantb : manta;
    assign addressult = shmant + addval;
    assign fract = addressult[24] ?
        addressult[23:1] :
        addressult[22:0];

    assign exp = addressult[24] ?
        (exp_pre + 1) :
        exp_pre;

endmodule
    
```

VHDL

```

library IEEE; use IEEE.STD_LOGIC_1164.all;
use ieee.numeric_std.all;
use IEEE.std_logic_unsigned.all;

entity shiftmant is
    port(alessb: in STD_LOGIC;
          manta: in STD_LOGIC_VECTOR(23 downto 0);
          mantb: in STD_LOGIC_VECTOR(23 downto 0);
          shamt: in STD_LOGIC_VECTOR(7 downto 0);
          shmant: out STD_LOGIC_VECTOR(23 downto 0));
end;

architecture synth of shiftmant is
    signal shiftedval: unsigned (23 downto 0);
    signal shiftamt_vector: STD_LOGIC_VECTOR (7 downto 0);
begin

    shiftedval <= SHIFT_RIGHT( unsigned(manta), to_in-
        teger(unsigned(shamt))) when alessb = '1'
        else SHIFT_RIGHT( unsigned(mantb), to_in-
        teger(unsigned(shamt)));

    shmant <= X"000000" when (shamt > 22)
        else STD_LOGIC_VECTOR(shiftedval);

end;

library IEEE; use IEEE.STD_LOGIC_1164.all;
use IEEE.STD_LOGIC_UNSIGNED.all;
use IEEE.STD_LOGIC_ARITH.all;

entity addmant is
    port(alessb: in STD_LOGIC;
          manta: in STD_LOGIC_VECTOR(23 downto 0);
          mantb: in STD_LOGIC_VECTOR(23 downto 0);
          shmant: in STD_LOGIC_VECTOR(23 downto 0);
          exp_pre: in STD_LOGIC_VECTOR(7 downto 0);
          fract: out STD_LOGIC_VECTOR(22 downto 0);
          exp: out STD_LOGIC_VECTOR(7 downto 0));
end;

architecture synth of addmant is
    signal addressult: STD_LOGIC_VECTOR(24 downto 0);
    signal addval: STD_LOGIC_VECTOR(23 downto 0);
begin

    addval <= mantb when alessb = '1' else manta;
    addressult <= ('0'&shmant) + addval;
    fract <= addressult(23 downto 1)
        when addressult(24) = '1'
        else addressult(22 downto 0);

    exp <= (exp_pre + 1)
        when addressult(24) = '1'
        else exp_pre;

end;
    
```

Exercise 5.41

(a) Figure on next page

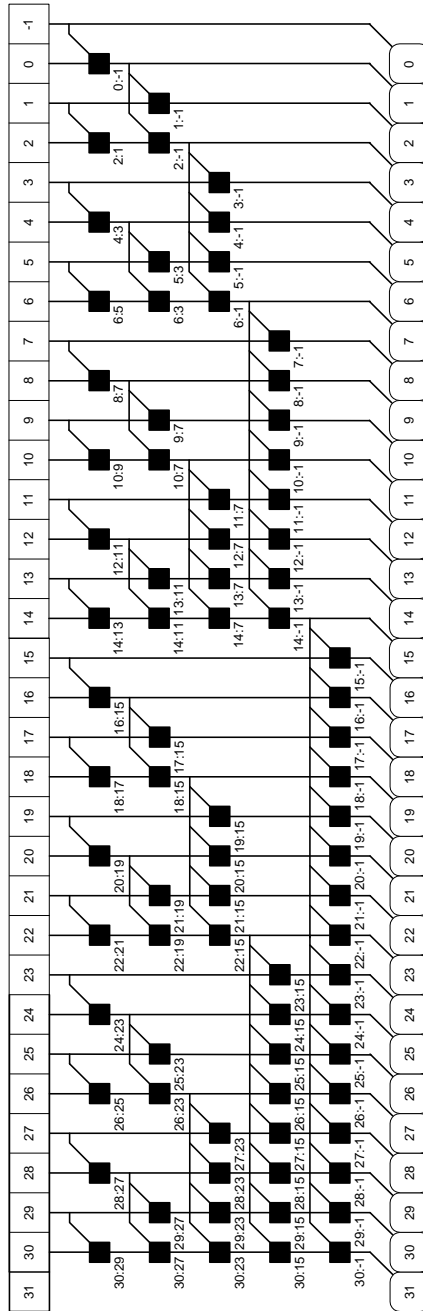

Row 1
 Row 2
 Row 3
 Row 4
 Row 5

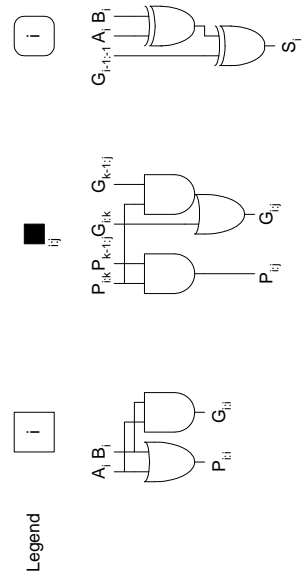

5.41 (b)

SystemVerilog

```

module prefixadd(input logic [31:0] a, b,
                input logic cin,
                output logic [31:0] s,
                output logic cout);

    logic [30:0] p, g;
    // p and g prefixes for rows 1 - 5
    logic [15:0] p1, p2, p3, p4, p5;
    logic [15:0] g1, g2, g3, g4, g5;

    pandg row0(a, b, p, g);
    blackbox row1({p[30],p[28],p[26],p[24],p[22],
                 p[20],p[18],p[16],p[14],p[12],
                 p[10],p[8],p[6],p[4],p[2],p[0]},
                {p[29],p[27],p[25],p[23],p[21],
                 p[19],p[17],p[15],p[13],p[11],
                 p[9],p[7],p[5],p[3],p[1],1'b0},
                {g[30],g[28],g[26],g[24],g[22],
                 g[20],g[18],g[16],g[14],g[12],
                 g[10],g[8],g[6],g[4],g[2],g[0]},
                {g[29],g[27],g[25],g[23],g[21],
                 g[19],g[17],g[15],g[13],g[11],
                 g[9],g[7],g[5],g[3],g[1],cin},
                p1, g1);

    blackbox row2({p[20],p[18],p[16],p[14],p[12],
                 p[10],p[8],p[6],p[4],p[2],p[0]},
                {p[19],p[17],p[15],p[13],p[11],
                 p[9],p[7],p[5],p[3],p[1],1'b0},
                {g[20],g[18],g[16],g[14],g[12],
                 g[10],g[8],g[6],g[4],g[2],g[0]},
                {g[19],g[17],g[15],g[13],g[11],
                 g[9],g[7],g[5],g[3],g[1],cin},
                p2, g2);

    blackbox row3({p[10],p[8],p[6],p[4],p[2],p[0]},
                {p[9],p[7],p[5],p[3],p[1],1'b0},
                {g[10],g[8],g[6],g[4],g[2],g[0]},
                {g[9],g[7],g[5],g[3],g[1],cin},
                p3, g3);

    blackbox row4({p[2],p[0]},
                {p[1],1'b0},
                {g[2],g[0]},
                {g[1],cin},
                p4, g4);

    blackbox row5({p[0]},
                {1'b0},
                {g[0]},
                {cin},
                p5, g5);

    cout = g5;
    s = {p4,p3,p2,p1,g5,g4,g3,g2,g1};
endmodule
    
```

VHDL

```

library IEEE; use IEEE.STD_LOGIC_1164.all;

entity prefixadd is
    port(a, b: in STD_LOGIC_VECTOR(31 downto 0);
         cin: in STD_LOGIC;
         s: out STD_LOGIC_VECTOR(31 downto 0);
         cout: out STD_LOGIC);
end;

architecture synth of prefixadd is
    component pgblock
        port(a, b: in STD_LOGIC_VECTOR(30 downto 0);
             p, g: out STD_LOGIC_VECTOR(30 downto 0));
    end component;

    component pgblackblock is
        port (pik, gik: in STD_LOGIC_VECTOR(15 downto 0);
             pkj, gkj: in STD_LOGIC_VECTOR(15 downto 0);
             pij: out STD_LOGIC_VECTOR(15 downto 0);
             gij: out STD_LOGIC_VECTOR(15 downto 0));
    end component;

    component subblock is
        port (a, b, g: in STD_LOGIC_VECTOR(31 downto 0);
             s: out STD_LOGIC_VECTOR(31 downto 0));
    end component;

    signal p, g: STD_LOGIC_VECTOR(30 downto 0);
    signal pik_1, pik_2, pik_3, pik_4, pik_5,
           gik_1, gik_2, gik_3, gik_4, gik_5,
           pkj_1, pkj_2, pkj_3, pkj_4, pkj_5,
           gkj_1, gkj_2, gkj_3, gkj_4, gkj_5,
           p1, p2, p3, p4, p5,
           g1, g2, g3, g4, g5:
        STD_LOGIC_VECTOR(15 downto 0);
    signal g6: STD_LOGIC_VECTOR(31 downto 0);

begin
    row0: pgblock
        port map(a(30 downto 0), b(30 downto 0), p, g);

    pik_1 <=
        (p(30)&p(28)&p(26)&p(24)&p(22)&p(20)&p(18)&p(16)&
         p(14)&p(12)&p(10)&p(8)&p(6)&p(4)&p(2)&p(0));
    gik_1 <=
        (g(30)&g(28)&g(26)&g(24)&g(22)&g(20)&g(18)&g(16)&
         g(14)&g(12)&g(10)&g(8)&g(6)&g(4)&g(2)&g(0));
    pkj_1 <=
        (p(29)&p(27)&p(25)&p(23)&p(21)&p(19)&p(17)&p(15)&
         p(13)&p(11)&p(9)&p(7)&p(5)&p(3)&p(1)&'0');
    gkj_1 <=
        (g(29)&g(27)&g(25)&g(23)&g(21)&g(19)&g(17)&g(15)&
         g(13)&g(11)&g(9)&g(7)&g(5)&g(3)&g(1)&cin);

    row1: pgblackblock
        port map(pik_1, gik_1, pkj_1, gkj_1,
                p1, g1);
end;
    
```

(continued on next page)
(continued from previous page)

SystemVerilog

```

blackbox row2({p1[15],p1[29],p1[13],p1[25],p1[11],
              p1[21],p1[9],p1[17],p1[7],p1[13],
              p1[5],p1[9],p1[3],p1[5],p1[1],p1[1]},
              {{2{p1[14]}}, {2{p1[12]}}, {2{p1[10]}},
               {2{p1[8]}}, {2{p1[6]}}, {2{p1[4]}},
               {2{p1[2]}}, {2{p1[0]}}},
              {g1[15],g1[29],g1[13],g1[25],g1[11],
               g1[21],g1[9],g1[17],g1[7],g1[13],
               g1[5],g1[9],g1[3],g1[5],g1[1],g1[1]},
              {{2{g1[14]}}, {2{g1[12]}}, {2{g1[10]}},
               {2{g1[8]}}, {2{g1[6]}}, {2{g1[4]}},
               {2{g1[2]}}, {2{g1[0]}}},
              p2, g2);

blackbox row3({p2[15],p2[14],p1[14],p1[27],p2[11],
              p2[10],p1[10],p1[19],p2[7],p2[6],
              p1[6],p1[11],p2[3],p2[2],p1[2],p1[3]},
              {{4{p2[13]}}, {4{p2[9]}}, {4{p2[5]}},
               {4{p2[1]}},
               {g2[15],g2[14],g1[14],g1[27],g2[11],
                g2[10],g1[10],g1[19],g2[7],g2[6],
                g1[6],g1[11],g2[3],g2[2],g1[2],g1[3]},
               {{4{g2[13]}}, {4{g2[9]}}, {4{g2[5]}},
                {4{g2[1]}}},
              p3, g3);

```

VHDL

```

pik_2 <= p1(15)&p(29)&p1(13)&p(25)&p1(11)&
         p(21)&p1(9)&p(17)&p1(7)&p(13)&
         p1(5)&p(9)&p1(3)&p(5)&p1(1)&p(1);

gik_2 <= g1(15)&g(29)&g1(13)&g(25)&g1(11)&
         g(21)&g1(9)&g(17)&g1(7)&g(13)&
         g1(5)&g(9)&g1(3)&g(5)&g1(1)&g(1);

pkj_2 <=
         p1(14)&p1(14)&p1(12)&p1(12)&p1(10)&p1(10)&
         p1(8)&p1(8)&p1(6)&p1(6)&p1(4)&p1(4)&
         p1(2)&p1(2)&p1(0)&p1(0);

gkj_2 <=
         g1(14)&g1(14)&g1(12)&g1(12)&g1(10)&g1(10)&
         g1(8)&g1(8)&g1(6)&g1(6)&g1(4)&g1(4)&
         g1(2)&g1(2)&g1(0)&g1(0);

row2: pgblackblock
      port map(pik_2, gik_2, pkj_2, gkj_2,
              p2, g2);

pik_3 <= p2(15)&p2(14)&p1(14)&p(27)&p2(11)&
         p2(10)&p1(10)&p(19)&p2(7)&p2(6)&
         p1(6)&p(11)&p2(3)&p2(2)&p1(2)&p(3);

gik_3 <= g2(15)&g2(14)&g1(14)&g(27)&g2(11)&
         g2(10)&g1(10)&g(19)&g2(7)&g2(6)&
         g1(6)&g(11)&g2(3)&g2(2)&g1(2)&g(3);

pkj_3 <= p2(13)&p2(13)&p2(13)&p2(13)&
         p2(9)&p2(9)&p2(9)&p2(9)&
         p2(5)&p2(5)&p2(5)&p2(5)&
         p2(1)&p2(1)&p2(1)&p2(1);

gkj_3 <= g2(13)&g2(13)&g2(13)&g2(13)&
         g2(9)&g2(9)&g2(9)&g2(9)&
         g2(5)&g2(5)&g2(5)&g2(5)&
         g2(1)&g2(1)&g2(1)&g2(1);

row3: pgblackblock
      port map(pik_3, gik_3, pkj_3, gkj_3, p3, g3);

```

(continued on next page)

SystemVerilog

```
blackbox row4({p3[15:12],p2[13:12],
              p1[12],p[23],p3[7:4],
              p2[5:4],p1[4],p[7]},
              {{8{p3[11]}},{8{p3[3]}}},
              {g3[15:12],g2[13:12],
              g1[12],g[23],g3[7:4],
              g2[5:4],g1[4],g[7]},
              {{8{g3[11]}},{8{g3[3]}}},
              p4, g4);

blackbox row5({p4[15:8],p3[11:8],p2[9:8],
              p1[8],p[15]},
              {{16{p4[7]}}},
              {g4[15:8],g3[11:8],g2[9:8],
              g1[8],g[15]},
              {{16{g4[7]}}},
              p5,g5);

sum row6({g5,g4[7:0],g3[3:0],g2[1:0],g1[0],cin},
         a, b, s);

// generate cout
assign cout = (a[31] & b[31]) |
              (g5[15] & (a[31] | b[31]));

endmodule
```

VHDL

```
pik_4 <= p3(15 downto 12)&p2(13 downto 12)&
         p1(12)&p(23)&p3(7 downto 4)&
         p2(5 downto 4)&p1(4)&p(7);
gik_4 <= g3(15 downto 12)&g2(13 downto 12)&
         g1(12)&g(23)&g3(7 downto 4)&
         g2(5 downto 4)&g1(4)&g(7);
pkj_4 <= p3(11)&p3(11)&p3(11)&p3(11)&
         p3(11)&p3(11)&p3(11)&p3(11)&
         p3(3)&p3(3)&p3(3)&p3(3)&
         p3(3)&p3(3)&p3(3)&p3(3);
gkj_4 <= g3(11)&g3(11)&g3(11)&g3(11)&
         g3(11)&g3(11)&g3(11)&g3(11)&
         g3(3)&g3(3)&g3(3)&g3(3)&
         g3(3)&g3(3)&g3(3)&g3(3);

row4: pgblackblock
port map(pik_4, gik_4, pkj_4, gkj_4, p4, g4);

pik_5 <= p4(15 downto 8)&p3(11 downto 8)&
         p2(9 downto 8)&p1(8)&p(15);
gik_5 <= g4(15 downto 8)&g3(11 downto 8)&
         g2(9 downto 8)&g1(8)&g(15);
pkj_5 <= p4(7)&p4(7)&p4(7)&p4(7)&
         p4(7)&p4(7)&p4(7)&p4(7)&
         p4(7)&p4(7)&p4(7)&p4(7)&
         p4(7)&p4(7)&p4(7)&p4(7);
gkj_5 <= g4(7)&g4(7)&g4(7)&g4(7)&
         g4(7)&g4(7)&g4(7)&g4(7)&
         g4(7)&g4(7)&g4(7)&g4(7)&
         g4(7)&g4(7)&g4(7)&g4(7);

row5: pgblackblock
port map(pik_5, gik_5, pkj_5, gkj_5, p5, g5);

g6 <= (g5 & g4(7 downto 0) & g3(3 downto 0) &
       g2(1 downto 0) & g1(0) & cin);

row6: sumblock
port map(g6, a, b, s);

-- generate cout
cout <= (a(31) and b(31)) or
        (g6(31) and (a(31) or b(31)));

end;
```

(continued on next page)

(continued from previous page)

SystemVerilog

```
module pandg(input  logic [30:0] a, b,
             output logic [30:0] p, g);

    assign p = a | b;
    assign g = a & b;

endmodule

module blackbox(input  logic [15:0] pleft, pright,
                gleft, gright,
                output logic [15:0] pnext, gnext);

    assign pnext = pleft & pright;
    assign gnext = pleft & gright | gleft;
endmodule

module sum(input  logic [31:0] g, a, b,
           output logic [31:0] s);

    assign s = a ^ b ^ g;

endmodule
```

VHDL

```
library IEEE; use IEEE.STD_LOGIC_1164.all;

entity pgblock is
    port(a, b: in  STD_LOGIC_VECTOR(30 downto 0);
         p, g: out STD_LOGIC_VECTOR(30 downto 0));
end;

architecture synth of pgblock is
begin
    p <= a or b;
    g <= a and b;
end;

library IEEE; use IEEE.STD_LOGIC_1164.all;

entity pgblackblock is
    port(pik, gik, pkj, gkj:
         in  STD_LOGIC_VECTOR(15 downto 0);
         pij, gij:
         out STD_LOGIC_VECTOR(15 downto 0));
end;

architecture synth of pgblackblock is
begin
    pij <= pik and pkj;
    gij <= gik or (pik and gkj);
end;

library IEEE; use IEEE.STD_LOGIC_1164.all;

entity sumblock is
    port(g, a, b: in  STD_LOGIC_VECTOR(31 downto 0);
         s:      out STD_LOGIC_VECTOR(31 downto 0));
end;

architecture synth of sumblock is
begin
    s <= a xor b xor g;
end;
```

5.41 (c) Using Equation 5.11 to find the delay of the prefix adder:

$$t_{PA} = t_{pg} + \log_2 N(t_{pg_prefix}) + t_{XOR}$$

We find the delays for each block:

$$t_{pg} = 100 \text{ ps}$$

$$t_{pg_prefix} = 200 \text{ ps}$$

$$t_{XOR} = 100 \text{ ps}$$

Thus,

$$t_{PA} = [100 + 5(200) + 100] \text{ ps} = 1200 \text{ ps} = \mathbf{1.2 \text{ ns}}$$

5.41 (d) To make a pipelined prefix adder, add pipeline registers between each of the rows of the prefix adder. Now each stage will take 200 ps plus the

sequencing overhead, $t_{pq} + t_{\text{setup}} = 80\text{ps}$. Thus each cycle is 280 ps and the design can run at 3.57 GHz.

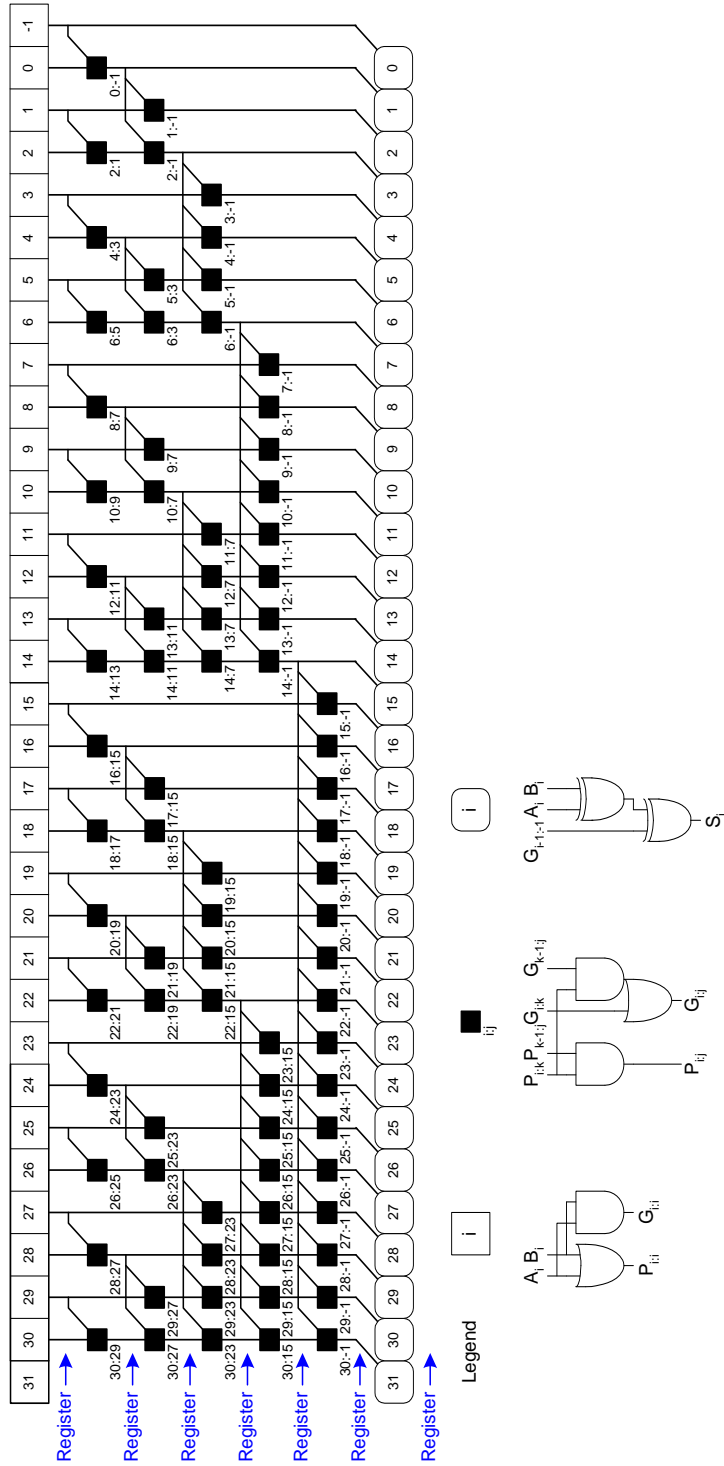

5.41 (e)

SystemVerilog

```

module prefixaddpipe(input  logic      clk, cin,
                    input  logic [31:0] a, b,
                    output logic [31:0] s, output cout);

    // p and g prefixes for rows 0 - 5
    logic [30:0] p0, p1, p2, p3, p4, p5;
    logic [30:0] g0, g1, g2, g3, g4, g5;
    logic p_1_0, p_1_1, p_1_2, p_1_3, p_1_4, p_1_5,
          g_1_0, g_1_1, g_1_2, g_1_3, g_1_4, g_1_5;

    // pipeline values for a and b
    logic [31:0] a0, a1, a2, a3, a4, a5,
                b0, b1, b2, b3, b4, b5;

    // row 0
    flop #(2) flop0_pg_1(clk, {1'b0,cin}, {p_1_0,g_1_0});
    pandg row0(clk, a[30:0], b[30:0], p0, g0);

    // row 1
    flop #(2) flop1_pg_1(clk, {p_1_0,g_1_0}, {p_1_1,g_1_1});
    flop #(30) flop1_pg(clk,
    {p0[29],p0[27],p0[25],p0[23],p0[21],p0[19],p0[17],p0[15],
     p0[13],p0[11],p0[9],p0[7],p0[5],p0[3],p0[1],
    g0[29],g0[27],g0[25],g0[23],g0[21],g0[19],g0[17],g0[15],
     g0[13],g0[11],g0[9],g0[7],g0[5],g0[3],g0[1]},
    {p1[29],p1[27],p1[25],p1[23],p1[21],p1[19],p1[17],p1[15],
     p1[13],p1[11],p1[9],p1[7],p1[5],p1[3],p1[1],
    g1[29],g1[27],g1[25],g1[23],g1[21],g1[19],g1[17],g1[15],
     g1[13],g1[11],g1[9],g1[7],g1[5],g1[3],g1[1]});

    blackbox row1(clk,
    {p0[30],p0[28],p0[26],p0[24],p0[22],
     p0[20],p0[18],p0[16],p0[14],p0[12],
     p0[10],p0[8],p0[6],p0[4],p0[2],p0[0]},
    {p0[29],p0[27],p0[25],p0[23],p0[21],
     p0[19],p0[17],p0[15],p0[13],p0[11],
     p0[9],p0[7],p0[5],p0[3],p0[1],1'b0},
    {g0[30],g0[28],g0[26],g0[24],g0[22],
     g0[20],g0[18],g0[16],g0[14],g0[12],
     g0[10],g0[8],g0[6],g0[4],g0[2],g0[0]},
    {g0[29],g0[27],g0[25],g0[23],g0[21],
     g0[19],g0[17],g0[15],g0[13],g0[11],
     g0[9],g0[7],g0[5],g0[3],g0[1],g_1_0},
    {p1[30],p1[28],p1[26],p1[24],p1[22],p1[20],
     p1[18],p1[16],p1[14],p1[12],p1[10],p1[8],
     p1[6],p1[4],p1[2],p1[0]},
    {g1[30],g1[28],g1[26],g1[24],g1[22],g1[20],
     g1[18],g1[16],g1[14],g1[12],g1[10],g1[8],
     g1[6],g1[4],g1[2],g1[0]});

    // row 2
    flop #(2) flop2_pg_1(clk, {p_1_1,g_1_1}, {p_1_2,g_1_2});
    flop #(30) flop2_pg(clk,
    {p1[28:27],p1[24:23],p1[20:19],p1[16:15],p1[12:11],

```

```

        p1[8:7],p1[4:3],p1[0],
g1[28:27],g1[24:23],g1[20:19],g1[16:15],g1[12:11],
g1[8:7],g1[4:3],g1[0]},
    {p2[28:27],p2[24:23],p2[20:19],p2[16:15],p2[12:11],
      p2[8:7],p2[4:3],p2[0]},
    g2[28:27],g2[24:23],g2[20:19],g2[16:15],g2[12:11],
    g2[8:7],g2[4:3],g2[0]};
    blackbox row2(clk,

{p1[30:29],p1[26:25],p1[22:21],p1[18:17],p1[14:13],p1[10:9],p1[6:5],p1[2:1]
},

    { {2{p1[28]}}, {2{p1[24]}}, {2{p1[20]}}, {2{p1[16]}}, {2{p1[12]}},
      {2{p1[8]}},
        {2{p1[4]}}, {2{p1[0]}} },

{g1[30:29],g1[26:25],g1[22:21],g1[18:17],g1[14:13],g1[10:9],g1[6:5],g1[2:1]
},

    { {2{g1[28]}}, {2{g1[24]}}, {2{g1[20]}}, {2{g1[16]}}, {2{g1[12]}},
      {2{g1[8]}},
        {2{g1[4]}}, {2{g1[0]}} },

{p2[30:29],p2[26:25],p2[22:21],p2[18:17],p2[14:13],p2[10:9],p2[6:5],p2[2:1]
},

{g2[30:29],g2[26:25],g2[22:21],g2[18:17],g2[14:13],g2[10:9],g2[6:5],g2[2:1]
} );

// row 3
flop #(2) flop3_pg_1(clk, {p_1_2,g_1_2}, {p_1_3,g_1_3});
flop #(30) flop3_pg(clk, {p2[26:23],p2[18:15],p2[10:7],p2[2:0]},
g2[26:23],g2[18:15],g2[10:7],g2[2:0]},
{p3[26:23],p3[18:15],p3[10:7],p3[2:0]},
g3[26:23],g3[18:15],g3[10:7],g3[2:0]};
    blackbox row3(clk,
        {p2[30:27],p2[22:19],p2[14:11],p2[6:3]},
    { {4{p2[26]}}, {4{p2[18]}}, {4{p2[10]}}, {4{p2[2]}} },
    {g2[30:27],g2[22:19],g2[14:11],g2[6:3]},
    { {4{g2[26]}}, {4{g2[18]}}, {4{g2[10]}}, {4{g2[2]}} },
    {p3[30:27],p3[22:19],p3[14:11],p3[6:3]},
    {g3[30:27],g3[22:19],g3[14:11],g3[6:3]});

// row 4
flop #(2) flop4_pg_1(clk, {p_1_3,g_1_3}, {p_1_4,g_1_4});
flop #(30) flop4_pg(clk, {p3[22:15],p3[6:0]},
g3[22:15],g3[6:0]},
        {p4[22:15],p4[6:0]},
g4[22:15],g4[6:0]};

    blackbox row4(clk,
        {p3[30:23],p3[14:7]},
    { {8{p3[22]}}, {8{p3[6]}} },
        {g3[30:23],g3[14:7]},
    { {8{g3[22]}}, {8{g3[6]}} },
    {p4[30:23],p4[14:7]},
    {g4[30:23],g4[14:7]});

// row 5
flop #(2) flop5_pg_1(clk, {p_1_4,g_1_4}, {p_1_5,g_1_5});
flop #(30) flop5_pg(clk, {p4[14:0],g4[14:0]},
        {p5[14:0],g5[14:0]});
    
```

```
blackbox row5(clk,
              p4[30:15],
              {16{p4[14]}},
              g4[30:15],
              {16{g4[14]}},
              p5[30:15], g5[30:15]);

// pipeline registers for a and b
flop #(64) flop0_ab(clk, {a,b}, {a0,b0});
flop #(64) flop1_ab(clk, {a0,b0}, {a1,b1});
flop #(64) flop2_ab(clk, {a1,b1}, {a2,b2});
flop #(64) flop3_ab(clk, {a2,b2}, {a3,b3});
flop #(64) flop4_ab(clk, {a3,b3}, {a4,b4});
flop #(64) flop5_ab(clk, {a4,b4}, {a5,b5});

sum row6(clk, {g5,g_1_5}, a5, b5, s);
// generate cout
assign cout = (a5[31] & b5[31]) | (g5[30] & (a5[31] | b5[31]));
endmodule

// submodules
module pandg(input logic clk,
            input logic [30:0] a, b,
            output logic [30:0] p, g);

    always_ff @(posedge clk)
    begin
        p <= a | b;
        g <= a & b;
    end

endmodule

module blackbox(input logic clk,
              input logic [15:0] pleft, pright, gleft, gright,
              output logic [15:0] pnext, gnext);

    always_ff @(posedge clk)
    begin
        pnext <= pleft & pright;
        gnext <= pleft & gright | gleft;
    end

endmodule

module sum(input logic clk,
          input logic [31:0] g, a, b,
          output logic [31:0] s);

    always_ff @(posedge clk)
    s <= a ^ b ^ g;
endmodule

module flop
#(parameter width = 8)
(input logic clk,
 input logic [width-1:0] d,
 output logic [width-1:0] q);

    always_ff @(posedge clk)
    q <= d;
endmodule
```

5.41 (e)

VHDL

```
library IEEE; use IEEE.STD_LOGIC_1164.all;

entity prefixaddpipe is
  port(clk: in STD_LOGIC;
        a, b: in STD_LOGIC_VECTOR(31 downto 0);
        cin: in STD_LOGIC;
        s: out STD_LOGIC_VECTOR(31 downto 0);
        cout: out STD_LOGIC);
end;

architecture synth of prefixaddpipe is
  component pgblock
    port(clk: in STD_LOGIC;
          a, b: in STD_LOGIC_VECTOR(30 downto 0);
          p, g: out STD_LOGIC_VECTOR(30 downto 0));
  end component;
  component subblock is
    port (clk: in STD_LOGIC;
          a, b, g: in STD_LOGIC_VECTOR(31 downto 0);
          s: out STD_LOGIC_VECTOR(31 downto 0));
  end component;
  component flop is generic(width: integer);
    port(clk: in STD_LOGIC;
          d: in STD_LOGIC_VECTOR(width-1 downto 0);
          q: out STD_LOGIC_VECTOR(width-1 downto 0));
  end component;
  component flopl is
    port(clk: in STD_LOGIC;
          d: in STD_LOGIC;
          q: out STD_LOGIC);
  end component;
  component row1 is
    port(clk: in STD_LOGIC;
          p0, g0: in STD_LOGIC_VECTOR(30 downto 0);
          p_1_0, g_1_0: in STD_LOGIC;
          p1, g1: out STD_LOGIC_VECTOR(30 downto 0));
  end component;
  component row2 is
    port(clk: in STD_LOGIC;
          p1, g1: in STD_LOGIC_VECTOR(30 downto 0);
          p2, g2: out STD_LOGIC_VECTOR(30 downto 0));
  end component;
  component row3 is
    port(clk: in STD_LOGIC;
          p2, g2: in STD_LOGIC_VECTOR(30 downto 0);
          p3, g3: out STD_LOGIC_VECTOR(30 downto 0));
  end component;
  component row4 is
    port(clk: in STD_LOGIC;
          p3, g3: in STD_LOGIC_VECTOR(30 downto 0);
          p4, g4: out STD_LOGIC_VECTOR(30 downto 0));
  end component;
  component row5 is
    port(clk: in STD_LOGIC;
          p4, g4: in STD_LOGIC_VECTOR(30 downto 0);
          p5, g5: out STD_LOGIC_VECTOR(30 downto 0));
  end component;
end;
```

```
-- p and g prefixes for rows 0 - 5
signal p0, p1, p2, p3, p4, p5: STD_LOGIC_VECTOR(30 downto 0);
signal g0, g1, g2, g3, g4, g5: STD_LOGIC_VECTOR(30 downto 0);

-- p and g prefixes for column -1, rows 0 - 5
signal p_1_0, p_1_1, p_1_2, p_1_3, p_1_4, p_1_5,
       g_1_0, g_1_1, g_1_2, g_1_3, g_1_4, g_1_5: STD_LOGIC;

-- pipeline values for a and b
signal a0, a1, a2, a3, a4, a5,
       b0, b1, b2, b3, b4, b5: STD_LOGIC_VECTOR(31 downto 0);

-- final generate signal
signal g5_all: STD_LOGIC_VECTOR(31 downto 0);

begin

-- p and g calculations
row0_reg: pgblock port map(clk, a(30 downto 0), b(30 downto 0), p0, g0);
row1_reg: row1 port map(clk, p0, g0, p_1_0, g_1_0, p1, g1);
row2_reg: row2 port map(clk, p1, g1, p2, g2);
row3_reg: row3 port map(clk, p2, g2, p3, g3);
row4_reg: row4 port map(clk, p3, g3, p4, g4);
row5_reg: row5 port map(clk, p4, g4, p5, g5);

-- pipeline registers for a and b
flop0_a: flop generic map(32) port map (clk, a, a0);
flop0_b: flop generic map(32) port map (clk, b, b0);
flop1_a: flop generic map(32) port map (clk, a0, a1);
flop1_b: flop generic map(32) port map (clk, b0, b1);
flop2_a: flop generic map(32) port map (clk, a1, a2);
flop2_b: flop generic map(32) port map (clk, b1, b2);
flop3_a: flop generic map(32) port map (clk, a2, a3);
flop3_b: flop generic map(32) port map (clk, b2, b3);
flop4_a: flop generic map(32) port map (clk, a3, a4);
flop4_b: flop generic map(32) port map (clk, b3, b4);
flop5_a: flop generic map(32) port map (clk, a4, a5);
flop5_b: flop generic map(32) port map (clk, b4, b5);

-- pipeline p and g for column -1
p_1_0 <= '0'; flop1_g0: flop1 port map (clk, cin, g_1_0);
flop1_p1: flop1 port map (clk, p_1_0, p_1_1);
flop1_g1: flop1 port map (clk, g_1_0, g_1_1);
flop1_p2: flop1 port map (clk, p_1_1, p_1_2);
flop1_g2: flop1 port map (clk, g_1_1, g_1_2);
flop1_p3: flop1 port map (clk, p_1_2, p_1_3); flop1_g3:
flop1 port map (clk, g_1_2, g_1_3);
flop1_p4: flop1 port map (clk, p_1_3, p_1_4);
flop1_g4: flop1 port map (clk, g_1_3, g_1_4);
flop1_p5: flop1 port map (clk, p_1_4, p_1_5);
flop1_g5: flop1 port map (clk, g_1_4, g_1_5);

-- generate sum and cout
g5_all <= (g5&g_1_5);
row6: subblock port map(clk, g5_all, a5, b5, s);

-- generate cout
cout <= (a5(31) and b5(31)) or (g5(30) and (a5(31) or b5(31)));
end;
```

```
library IEEE; use IEEE.STD_LOGIC_1164.all;
entity pgblock is
  port(clk: in STD_LOGIC;
```

```
        a, b: in  STD_LOGIC_VECTOR(30 downto 0);
        p, g: out STD_LOGIC_VECTOR(30 downto 0));
end;

architecture synth of pgblock is
begin
    process(clk) begin
        if rising_edge(clk) then
            p <= a or b;
            g <= a and b;
        end if;
    end process;
end;

library IEEE; use IEEE.STD_LOGIC_1164.all;

entity blackbox is
    port(clk: in  STD_LOGIC;
          pik, pkj, gik, gkj:
            in  STD_LOGIC_VECTOR(15 downto 0);
          pij, gij:
            out STD_LOGIC_VECTOR(15 downto 0));
end;

architecture synth of blackbox is
begin
    process(clk) begin
        if rising_edge(clk) then
            pij <= pik and pkj;
            gij <= gik or (pik and gkj);
        end if;
    end process;
end;

library IEEE; use IEEE.STD_LOGIC_1164.all;

entity sumblock is
    port(clk: in  STD_LOGIC;
          g, a, b: in  STD_LOGIC_VECTOR(31 downto 0);
          s:      out STD_LOGIC_VECTOR(31 downto 0));
end;

architecture synth of sumblock is
begin
    process(clk) begin
        if rising_edge(clk) then
            s <= a xor b xor g;
        end if;
    end process;
end;

library IEEE; use IEEE.STD_LOGIC_1164.all; use IEEE.STD_LOGIC_ARITH.all;
entity flop is -- parameterizable flip flop
    generic(width: integer);
    port(clk: in  STD_LOGIC;
          d:   in  STD_LOGIC_VECTOR(width-1 downto 0);
          q:   out STD_LOGIC_VECTOR(width-1 downto 0));
end;

architecture synth of flop is
begin
    process(clk) begin
        if rising_edge(clk) then
            q <= d;
        end if;
    end process;
end;
```

```
        end if;
    end process;
end;

library IEEE; use IEEE.STD_LOGIC_1164.all; use IEEE.STD_LOGIC_ARITH.all;
entity flopl is -- 1-bit flip flop
    port (clk:      in  STD_LOGIC;
          d:        in  STD_LOGIC;
          q:        out STD_LOGIC);
end;

architecture synth of flopl is
begin
    process (clk) begin
        if rising_edge (clk) then
            q <= d;
        end if;
    end process;
end;

library IEEE; use IEEE.STD_LOGIC_1164.all;

entity row1 is
    port (clk:      in  STD_LOGIC;
          p0, g0:   in  STD_LOGIC_VECTOR(30 downto 0);
          p_l_0, g_l_0: in  STD_LOGIC;
          p1, g1:   out STD_LOGIC_VECTOR(30 downto 0));
end;

architecture synth of row1 is
    component blackbox is
        port (clk:      in  STD_LOGIC;
              pik, pkj: in  STD_LOGIC_VECTOR(15 downto 0);
              gik, gkj: in  STD_LOGIC_VECTOR(15 downto 0);
              pij:      out STD_LOGIC_VECTOR(15 downto 0);
              gij:      out STD_LOGIC_VECTOR(15 downto 0));
    end component;
    component flop is generic (width: integer);
        port (clk: in  STD_LOGIC;
              d:   in  STD_LOGIC_VECTOR(width-1 downto 0);
              q:   out STD_LOGIC_VECTOR(width-1 downto 0));
    end component;

    -- internal signals for calculating p, g
    signal pik_0, gik_0, pkj_0, gkj_0,
           pij_0, gij_0: STD_LOGIC_VECTOR(15 downto 0);

    -- internal signals for pipeline registers
    signal pg0_in, pgl_out: STD_LOGIC_VECTOR(29 downto 0);

begin
    pg0_in <= (p0(29)&p0(27)&p0(25)&p0(23)&p0(21)&p0(19)&p0(17)&p0(15)&
              p0(13)&p0(11)&p0(9)&p0(7)&p0(5)&p0(3)&p0(1)&
              g0(29)&g0(27)&g0(25)&g0(23)&g0(21)&g0(19)&g0(17)&g0(15)&
              g0(13)&g0(11)&g0(9)&g0(7)&g0(5)&g0(3)&g0(1));
    flopl_pg: flop generic map(30) port map (clk, pg0_in, pgl_out);

    p1(29) <= pgl_out(29); p1(27) <= pgl_out(28); p1(25) <= pgl_out(27);
    p1(23) <= pgl_out(26);
    p1(21) <= pgl_out(25); p1(19) <= pgl_out(24); p1(17) <= pgl_out(23);
    p1(15) <= pgl_out(22); p1(13) <= pgl_out(21); p1(11) <= pgl_out(20);
    p1(9) <= pgl_out(19); p1(7) <= pgl_out(18); p1(5) <= pgl_out(17);
    p1(3) <= pgl_out(16); p1(1) <= pgl_out(15);
    g1(29) <= pgl_out(14); g1(27) <= pgl_out(13); g1(25) <= pgl_out(12);
    g1(23) <= pgl_out(11); g1(21) <= pgl_out(10); g1(19) <= pgl_out(9);
    g1(17) <= pgl_out(8); g1(15) <= pgl_out(7); g1(13) <= pgl_out(6);
```

```
g1(11) <= pg1_out(5); g1(9) <= pg1_out(4); g1(7) <= pg1_out(3);
g1(5) <= pg1_out(2); g1(3) <= pg1_out(1); g1(1) <= pg1_out(0);

-- pg calculations
pik_0 <= (p0(30)&p0(28)&p0(26)&p0(24)&p0(22)&p0(20)&p0(18)&p0(16)&
p0(14)&p0(12)&p0(10)&p0(8)&p0(6)&p0(4)&p0(2)&p0(0));
gik_0 <= (g0(30)&g0(28)&g0(26)&g0(24)&g0(22)&g0(20)&g0(18)&g0(16)&
g0(14)&g0(12)&g0(10)&g0(8)&g0(6)&g0(4)&g0(2)&g0(0));
pkj_0 <= (p0(29)&p0(27)&p0(25)&p0(23)&p0(21)&p0(19)&p0(17)&p0(15)&
p0(13)&p0(11)&p0(9)&p0(7)&p0(5)&p0(3)&p0(1)&p_1_0);
gkj_0 <= (g0(29)&g0(27)&g0(25)&g0(23)&g0(21)&g0(19)&g0(17)&g0(15)&
g0(13)&g0(11)&g0(9)&g0(7)&g0(5)&g0(3)&g0(1)&g_1_0);

row1: blackbox port map(clk, pik_0, pkj_0, gik_0, gkj_0, pij_0, gij_0);

p1(30) <= pij_0(15); p1(28) <= pij_0(14); p1(26) <= pij_0(13);
p1(24) <= pij_0(12); p1(22) <= pij_0(11); p1(20) <= pij_0(10);
p1(18) <= pij_0(9); p1(16) <= pij_0(8); p1(14) <= pij_0(7);
p1(12) <= pij_0(6); p1(10) <= pij_0(5); p1(8) <= pij_0(4);
p1(6) <= pij_0(3); p1(4) <= pij_0(2); p1(2) <= pij_0(1); p1(0) <= pij_0(0);

g1(30) <= gij_0(15); g1(28) <= gij_0(14); g1(26) <= gij_0(13);
g1(24) <= gij_0(12); g1(22) <= gij_0(11); g1(20) <= gij_0(10);
g1(18) <= gij_0(9); g1(16) <= gij_0(8); g1(14) <= gij_0(7);
g1(12) <= gij_0(6); g1(10) <= gij_0(5); g1(8) <= gij_0(4);
g1(6) <= gij_0(3); g1(4) <= gij_0(2); g1(2) <= gij_0(1); g1(0) <= gij_0(0);
end;

library IEEE; use IEEE.STD_LOGIC_1164.all;

entity row2 is
  port(clk: in STD_LOGIC;
        p1, g1: in STD_LOGIC_VECTOR(30 downto 0);
        p2, g2: out STD_LOGIC_VECTOR(30 downto 0));
end;

architecture synth of row2 is
  component blackbox is
    port (clk: in STD_LOGIC;
          pik, pkj: in STD_LOGIC_VECTOR(15 downto 0);
          gik, gkj: in STD_LOGIC_VECTOR(15 downto 0);
          pij: out STD_LOGIC_VECTOR(15 downto 0);
          gij: out STD_LOGIC_VECTOR(15 downto 0));
  end component;
  component flop is generic(width: integer);
    port(clk: in STD_LOGIC;
          d: in STD_LOGIC_VECTOR(width-1 downto 0);
          q: out STD_LOGIC_VECTOR(width-1 downto 0));
  end component;

  -- internal signals for calculating p, g
  signal pik_1, gik_1, pkj_1, gkj_1,
        pij_1, gij_1: STD_LOGIC_VECTOR(15 downto 0);

  -- internal signals for pipeline registers
  signal pg1_in, pg2_out: STD_LOGIC_VECTOR(29 downto 0);

begin
  pg1_in <= (p1(28 downto 27)&p1(24 downto 23)&p1(20 downto 19)&
p1(16 downto 15)&
p1(12 downto 11)&p1(8 downto 7)&p1(4 downto 3)&p1(0)&
g1(28 downto 27)&g1(24 downto 23)&g1(20 downto 19)&
g1(16 downto 15)&
g1(12 downto 11)&g1(8 downto 7)&g1(4 downto 3)&g1(0));
  flop2_pg: flop generic map(30) port map (clk, pg1_in, pg2_out);
```



```
p2(28 downto 27) <= pg2_out(29 downto 28);
p2(24 downto 23) <= pg2_out(27 downto 26);
p2(20 downto 19) <= pg2_out(25 downto 24);
p2(16 downto 15) <= pg2_out(23 downto 22);
p2(12 downto 11) <= pg2_out(21 downto 20);
p2(8 downto 7) <= pg2_out(19 downto 18);
p2(4 downto 3) <= pg2_out(17 downto 16);
p2(0) <= pg2_out(15);
g2(28 downto 27) <= pg2_out(14 downto 13);
g2(24 downto 23) <= pg2_out(12 downto 11);
g2(20 downto 19) <= pg2_out(10 downto 9);
g2(16 downto 15) <= pg2_out(8 downto 7);
g2(12 downto 11) <= pg2_out(6 downto 5);
g2(8 downto 7) <= pg2_out(4 downto 3);
g2(4 downto 3) <= pg2_out(2 downto 1); g2(0) <= pg2_out(0);

-- pg calculations
pik_1 <= (p1(30 downto 29)&p1(26 downto 25)&p1(22 downto 21)&
         p1(18 downto 17)&p1(14 downto 13)&p1(10 downto 9)&
         p1(6 downto 5)&p1(2 downto 1));
gik_1 <= (g1(30 downto 29)&g1(26 downto 25)&g1(22 downto 21)&
         g1(18 downto 17)&g1(14 downto 13)&g1(10 downto 9)&
         g1(6 downto 5)&g1(2 downto 1));
pkj_1 <= (p1(28)&p1(28)&p1(24)&p1(24)&p1(20)&p1(20)&p1(16)&p1(16)&
         p1(12)&p1(12)&p1(8)&p1(8)&p1(4)&p1(4)&p1(0)&p1(0));
gkj_1 <= (g1(28)&g1(28)&g1(24)&g1(24)&g1(20)&g1(20)&g1(16)&g1(16)&
         g1(12)&g1(12)&g1(8)&g1(8)&g1(4)&g1(4)&g1(0)&g1(0));

row2: blackbox
    port map(clk, pik_1, pkj_1, gik_1, gkj_1, pij_1, gij_1);

p2(30 downto 29) <= pij_1(15 downto 14);
p2(26 downto 25) <= pij_1(13 downto 12);
p2(22 downto 21) <= pij_1(11 downto 10);
p2(18 downto 17) <= pij_1(9 downto 8);
p2(14 downto 13) <= pij_1(7 downto 6); p2(10 downto 9) <= pij_1(5 downto 4);
p2(6 downto 5) <= pij_1(3 downto 2); p2(2 downto 1) <= pij_1(1 downto 0);

g2(30 downto 29) <= gij_1(15 downto 14);
g2(26 downto 25) <= gij_1(13 downto 12);
g2(22 downto 21) <= gij_1(11 downto 10);
g2(18 downto 17) <= gij_1(9 downto 8);
g2(14 downto 13) <= gij_1(7 downto 6); g2(10 downto 9) <= gij_1(5 downto 4);
g2(6 downto 5) <= gij_1(3 downto 2); g2(2 downto 1) <= gij_1(1 downto 0);

end;

library IEEE; use IEEE.STD_LOGIC_1164.all;

entity row3 is
    port(clk: in STD_LOGIC;
          p2, g2: in STD_LOGIC_VECTOR(30 downto 0);
          p3, g3: out STD_LOGIC_VECTOR(30 downto 0));
end;

architecture synth of row3 is
    component blackbox is
        port (clk: in STD_LOGIC;
              pik, pkj: in STD_LOGIC_VECTOR(15 downto 0);
              gik, gkj: in STD_LOGIC_VECTOR(15 downto 0);
              pij: out STD_LOGIC_VECTOR(15 downto 0);
              gij: out STD_LOGIC_VECTOR(15 downto 0));
    end component;
    component flop is generic(width: integer);
        port(clk: in STD_LOGIC;
              d: in STD_LOGIC_VECTOR(width-1 downto 0));
```

```

        q: out STD_LOGIC_VECTOR(width-1 downto 0));
    end component;

    -- internal signals for calculating p, g
    signal pik_2, gik_2, pkj_2, gkj_2,
           pij_2, gij_2: STD_LOGIC_VECTOR(15 downto 0);

    -- internal signals for pipeline registers
    signal pg2_in, pg3_out: STD_LOGIC_VECTOR(29 downto 0);

begin
    pg2_in <= (p2(26 downto 23)&p2(18 downto 15)&p2(10 downto 7)&
              p2(2 downto 0)&
              g2(26 downto 23)&g2(18 downto 15)&g2(10 downto 7)&g2(2 downto 0));
    flop3_pg: flop generic map(30) port map (clk, pg2_in, pg3_out);
    p3(26 downto 23) <= pg3_out(29 downto 26);
    p3(18 downto 15) <= pg3_out(25 downto 22);
    p3(10 downto 7) <= pg3_out(21 downto 18);
    p3(2 downto 0) <= pg3_out(17 downto 15);
    g3(26 downto 23) <= pg3_out(14 downto 11);
    g3(18 downto 15) <= pg3_out(10 downto 7);
    g3(10 downto 7) <= pg3_out(6 downto 3);
    g3(2 downto 0) <= pg3_out(2 downto 0);

    -- pg calculations
    pik_2 <= (p2(30 downto 27)&p2(22 downto 19)&
              p2(14 downto 11)&p2(6 downto 3));
    gik_2 <= (g2(30 downto 27)&g2(22 downto 19)&
              g2(14 downto 11)&g2(6 downto 3));
    pkj_2 <= (p2(26)&p2(26)&p2(26)&p2(26)&
              p2(18)&p2(18)&p2(18)&p2(18)&
              p2(10)&p2(10)&p2(10)&p2(10)&
              p2(2)&p2(2)&p2(2)&p2(2));
    gkj_2 <= (g2(26)&g2(26)&g2(26)&g2(26)&
              g2(18)&g2(18)&g2(18)&g2(18)&
              g2(10)&g2(10)&g2(10)&g2(10)&
              g2(2)&g2(2)&g2(2)&g2(2));

    row3: blackbox
        port map(clk, pik_2, pkj_2, gik_2, gkj_2, pij_2, gij_2);

    p3(30 downto 27) <= pij_2(15 downto 12);
    p3(22 downto 19) <= pij_2(11 downto 8);
    p3(14 downto 11) <= pij_2(7 downto 4); p3(6 downto 3) <= pij_2(3 downto 0);
    g3(30 downto 27) <= gij_2(15 downto 12);
    g3(22 downto 19) <= gij_2(11 downto 8);
    g3(14 downto 11) <= gij_2(7 downto 4); g3(6 downto 3) <= gij_2(3 downto 0);

end;

library IEEE; use IEEE.STD_LOGIC_1164.all;

entity row4 is
    port(clk: in STD_LOGIC;
          p3, g3: in STD_LOGIC_VECTOR(30 downto 0);
          p4, g4: out STD_LOGIC_VECTOR(30 downto 0));
end;

architecture synth of row4 is
    component blackbox is
        port (clk: in STD_LOGIC;
              pik, pkj: in STD_LOGIC_VECTOR(15 downto 0);
              gik, gkj: in STD_LOGIC_VECTOR(15 downto 0);
              pij: out STD_LOGIC_VECTOR(15 downto 0);
              gij: out STD_LOGIC_VECTOR(15 downto 0));
    end component;

```

```
component flop is generic(width: integer);
  port(clk: in STD_LOGIC;
        d: in STD_LOGIC_VECTOR(width-1 downto 0);
        q: out STD_LOGIC_VECTOR(width-1 downto 0));
end component;

-- internal signals for calculating p, g
signal pik_3, gik_3, pkj_3, gkj_3,
      pij_3, gij_3: STD_LOGIC_VECTOR(15 downto 0);

-- internal signals for pipeline registers
signal pg3_in, pg4_out: STD_LOGIC_VECTOR(29 downto 0);

begin
  pg3_in <= (p3(22 downto 15)&p3(6 downto 0)&g3(22 downto 15)&g3(6 downto 0));
  flop4_pg: flop generic map(30) port map (clk, pg3_in, pg4_out);
  p4(22 downto 15) <= pg4_out(29 downto 22);
  p4(6 downto 0) <= pg4_out(21 downto 15);
  g4(22 downto 15) <= pg4_out(14 downto 7);
  g4(6 downto 0) <= pg4_out(6 downto 0);

  -- pg calculations
  pik_3 <= (p3(30 downto 23)&p3(14 downto 7));
  gik_3 <= (g3(30 downto 23)&g3(14 downto 7));
  pkj_3 <= (p3(22)&p3(22)&p3(22)&p3(22)&p3(22)&p3(22)&p3(22)&p3(22)&
    p3(6)&p3(6)&p3(6)&p3(6)&p3(6)&p3(6)&p3(6)&p3(6));
  gkj_3 <= (g3(22)&g3(22)&g3(22)&g3(22)&g3(22)&g3(22)&g3(22)&g3(22)&
    g3(6)&g3(6)&g3(6)&g3(6)&g3(6)&g3(6)&g3(6)&g3(6));

  row4: blackbox
    port map(clk, pik_3, pkj_3, gik_3, gkj_3, pij_3, gij_3);

  p4(30 downto 23) <= pij_3(15 downto 8);
  p4(14 downto 7) <= pij_3(7 downto 0);
  g4(30 downto 23) <= gij_3(15 downto 8);
  g4(14 downto 7) <= gij_3(7 downto 0);

end;

library IEEE; use IEEE.STD_LOGIC_1164.all;

entity row5 is
  port(clk: in STD_LOGIC;
        p4, g4: in STD_LOGIC_VECTOR(30 downto 0);
        p5, g5: out STD_LOGIC_VECTOR(30 downto 0));
end;

architecture synth of row5 is
  component blackbox is
    port (clk: in STD_LOGIC;
          pik, pkj: in STD_LOGIC_VECTOR(15 downto 0);
          gik, gkj: in STD_LOGIC_VECTOR(15 downto 0);
          pij: out STD_LOGIC_VECTOR(15 downto 0);
          gij: out STD_LOGIC_VECTOR(15 downto 0));
  end component;
  component flop is generic(width: integer);
    port(clk: in STD_LOGIC;
          d: in STD_LOGIC_VECTOR(width-1 downto 0);
          q: out STD_LOGIC_VECTOR(width-1 downto 0));
  end component;

  -- internal signals for calculating p, g
  signal pik_4, gik_4, pkj_4, gkj_4,
        pij_4, gij_4: STD_LOGIC_VECTOR(15 downto 0);

  -- internal signals for pipeline registers
  signal pg4_in, pg5_out: STD_LOGIC_VECTOR(29 downto 0);
```

```

begin

    pg4_in <= (p4(14 downto 0)&g4(14 downto 0));
    flop4_pg: flop generic map(30) port map (clk, pg4_in, pg5_out);
    p5(14 downto 0) <= pg5_out(29 downto 15); g5(14 downto 0) <= pg5_out(14
    downto 0);

    -- pg calculations
    pik_4 <= p4(30 downto 15);
    gik_4 <= g4(30 downto 15);
    pkj_4 <= p4(14)&p4(14)&p4(14)&p4(14)&
    p4(14)&p4(14)&p4(14)&p4(14)&
    p4(14)&p4(14)&p4(14)&p4(14)&
    p4(14)&p4(14)&p4(14)&p4(14);
    gkj_4 <= g4(14)&g4(14)&g4(14)&g4(14)&
    g4(14)&g4(14)&g4(14)&g4(14)&
    g4(14)&g4(14)&g4(14)&g4(14)&
    g4(14)&g4(14)&g4(14)&g4(14);

    row5: blackbox
        port map(clk, pik_4, gik_4, pkj_4, gkj_4, pij_4, gij_4);
        p5(30 downto 15) <= pij_4; g5(30 downto 15) <= gij_4;

end;
```

Exercise 5.43

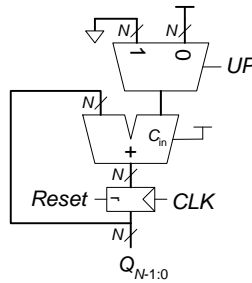

FIGURE 5.7 Up/Down counter

Exercise 5.45

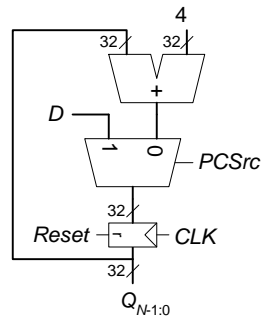

FIGURE 5.8 32-bit counter that increments by 4 or loads a new value, D

Exercise 5.47

SystemVerilog

```

module scanflop4(input  logic      clk, test, sin,
                input  logic [3:0] d,
                output logic [3:0] q,
                output logic      sout);

    always_ff @(posedge clk)
        if (test)
            q <= d;
        else
            q <= {q[2:0], sin};

    assign sout = q[3];
endmodule
    
```

VHDL

```

library IEEE; use IEEE.STD_LOGIC_1164.all;

entity scanflop4 is
    port(clk, test, sin: in STD_LOGIC;
         d: in STD_LOGIC_VECTOR(3 downto 0);
         q: inout STD_LOGIC_VECTOR(3 downto 0);
         sout: out STD_LOGIC);
end;

architecture synth of scanflop4 is
begin
    process(clk, test) begin
        if rising_edge(clk) then
            if test then
                q <= d;
            else
                q <= q(2 downto 0) & sin;
            end if;
        end if;
    end process;

    sout <= q(3);
end;
    
```

Exercise 5.49

<http://www.intel.com/design/flash/articles/what.htm>

Flash memory is a nonvolatile memory because it retains its contents after power is turned off. Flash memory allows the user to electrically program and erase information. Flash memory uses memory cells similar to an EEPROM, but with a much thinner, precisely grown oxide between a floating gate and the substrate (see Figure 5.9).

Flash programming occurs when electrons are placed on the floating gate. This is done by forcing a large voltage (usually 10 to 12 volts) on the control gate. Electrons quantum-mechanically tunnel from the source through the thin oxide onto the control gate. Because the floating gate is completely insulated by oxide, the charges are trapped on the floating gate during normal operation. If electrons are stored on the floating gate, it blocks the effect of the control gate. The electrons on the floating gate can be removed by reversing the procedure, i.e., by placing a large negative voltage on the control gate.

The default state of a flash bitcell (when there are no electrons on the floating gate) is ON, because the channel will conduct when the wordline is HIGH. After the bitcell is programmed (i.e., when there are electrons on the floating gate), the state of the bitcell is OFF, because the floating gate blocks the effect of the control gate. Flash memory is a key element in thumb drives, cell phones, digital cameras, Blackberries, and other low-power devices that must retain their memory when turned off.

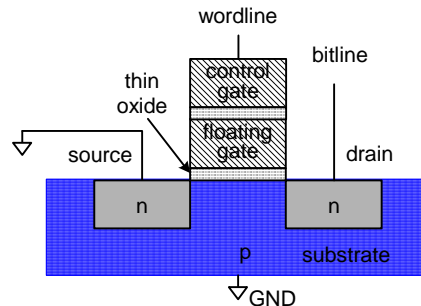
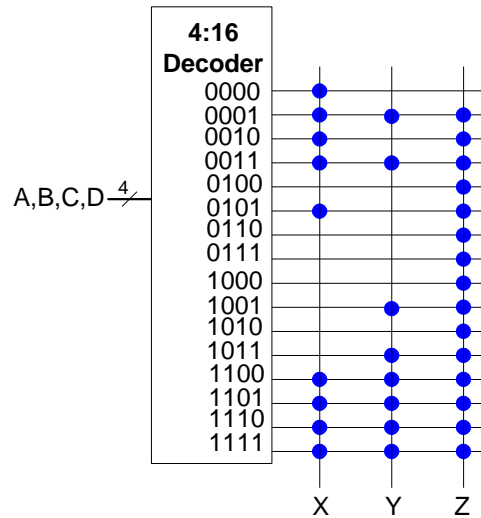

FIGURE 5.9 Flash EEPROM

Exercise 5.51



Exercise 5.53

- (a) Number of inputs = $2 \times 16 + 1 = 33$
 Number of outputs = $16 + 1 = 17$

Thus, this would require a 2^{33} x 17-bit ROM.

- (b) Number of inputs = 16
 Number of outputs = 16

Thus, this would require a 2^{16} x 16-bit ROM.

- (c) Number of inputs = 16
 Number of outputs = 4

Thus, this would require a 2^{16} x 4-bit ROM.

All of these implementations are not good design choices. They could all be implemented in a smaller amount of hardware using discrete gates.

Exercise 5.55

(a) 1 LE

(A) data 1	(B) data 2	(C) data 3	(D) data 4	(Y) LUT output
0	0	0	0	1
0	0	0	1	1
0	0	1	0	1
0	0	1	1	1
0	1	0	0	1
0	1	0	1	1
0	1	1	0	1
0	1	1	1	1
1	0	0	0	1
1	0	0	1	1
1	0	1	0	1
1	0	1	1	1
1	1	0	0	0
1	1	0	1	1
1	1	1	0	0
1	1	1	1	1

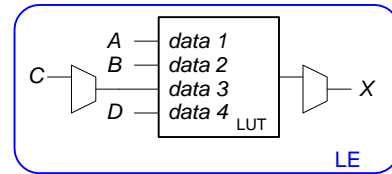

(b) 2 LEs

(B) data 1	(C) data 2	(D) data 3	(E) data 4	(X) LUT output
0	0	0	0	1
0	0	0	1	1
0	0	1	0	1
0	0	1	1	1
0	1	0	0	1
0	1	0	1	0
0	1	1	0	0
0	1	1	1	0
1	0	0	0	1
1	0	0	1	0
1	0	1	0	0
1	0	1	1	0
1	1	0	0	1
1	1	0	1	0
1	1	1	0	0
1	1	1	1	0

(A) data 1	(X) data 2	data 3	data 4	(Y) LUT output
0	0	X	X	0
0	1	X	X	1
1	0	X	X	1
1	1	X	X	1

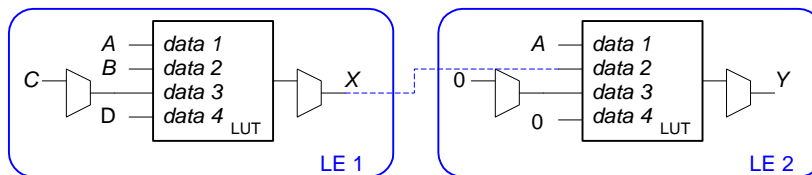

(c) 2 LEs

(A)	(B)	(C)	(D)	(Y)	(A)	(B)	(C)	(D)	(Z)
data 1	data 2	data 3	data 4	LUT output	data 1	data 2	data 3	data 4	LUT output
0	0	0	0	0	0	0	0	0	0
0	0	0	1	1	0	0	0	1	0
0	0	1	0	0	0	0	1	0	0
0	0	1	1	1	0	0	1	1	0
0	1	0	0	0	0	1	0	0	0
0	1	0	1	1	0	1	0	1	1
0	1	1	0	0	0	1	1	0	0
0	1	1	1	1	0	1	1	1	1
1	0	0	0	0	1	0	0	0	0
1	0	0	1	1	1	0	0	1	1
1	0	1	0	1	1	0	1	0	0
1	0	1	1	1	1	0	1	1	0
1	1	0	0	0	1	1	0	0	0
1	1	0	1	1	1	1	0	1	1
1	1	1	0	0	1	1	1	0	0
1	1	1	1	1	1	1	1	1	1

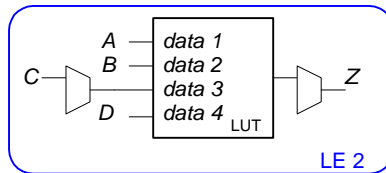
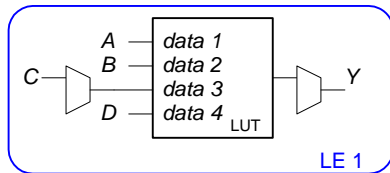

(d) 2 LEs

(A_3) data 1	(A_2) data 2	(A_1) data 3	(A_0) data 4	(D) LUT output	(A_3) data 1	(A_2) data 2	(A_1) data 3	(A_0) data 4	(P) LUT output
0	0	0	0	0	0	0	0	0	0
0	0	0	1	0	0	0	0	1	0
0	0	1	0	0	0	0	1	0	1
0	0	1	1	1	0	0	1	1	1
0	1	0	0	0	0	1	0	0	0
0	1	0	1	0	0	1	0	1	1
0	1	1	0	1	0	1	1	0	0
0	1	1	1	0	0	1	1	1	1
1	0	0	0	0	1	0	0	0	0
1	0	0	1	1	1	0	0	1	0
1	0	1	0	0	1	0	1	0	0
1	0	1	1	0	1	0	1	1	1
1	1	0	0	1	1	1	0	0	0
1	1	0	1	0	1	1	0	1	1
1	1	1	0	0	1	1	1	0	0
1	1	1	1	1	1	1	1	1	0

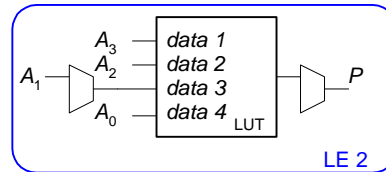
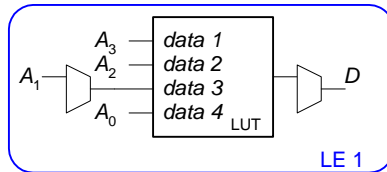

(e) 2 LEs

(A ₃) data 1	(A ₂) data 2	(A ₁) data 3	(A ₀) data 4	(Y ₀) LUT output	(A ₃) data 1	(A ₂) data 2	(A ₁) data 3	(A ₀) data 4	(Y ₁) LUT output
0	0	0	0	0	0	0	0	0	0
0	0	0	1	0	0	0	0	1	0
0	0	1	0	1	0	0	1	0	0
0	0	1	1	1	0	0	1	1	0
0	1	0	0	0	0	1	0	0	1
0	1	0	1	0	0	1	0	1	1
0	1	1	0	0	0	1	1	0	1
0	1	1	1	0	0	1	1	1	1
1	0	0	0	1	1	0	0	0	1
1	0	0	1	1	1	0	0	1	1
1	0	1	0	1	1	0	1	0	1
1	0	1	1	1	1	0	1	1	1
1	1	0	0	1	1	1	0	0	1
1	1	0	1	1	1	1	0	1	1
1	1	1	0	1	1	1	1	0	1
1	1	1	1	1	1	1	1	1	1

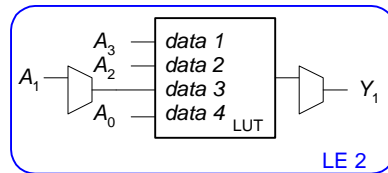
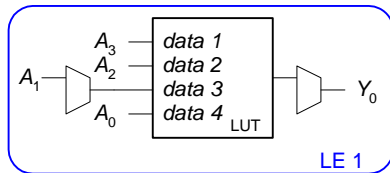

Exercise 5.57

(a) 5 LEs (2 for next state logic and state registers, 3 for output logic)

(b)

$$\begin{aligned}
 t_{pd} &= t_{pd_LE} + t_{wire} \\
 &= (381+246) \text{ ps} \\
 &= 627 \text{ ps}
 \end{aligned}$$

$$\begin{aligned}
 T_c &\geq t_{pcq} + t_{pd} + t_{setup} \\
 &\geq [199 + 627 + 76] \text{ ps} \\
 &= 902 \text{ ps}
 \end{aligned}$$

$$f = 1 / 902 \text{ ps} = \mathbf{1.1 \text{ GHz}}$$

(c)

First, we check that there is no hold time violation with this amount of clock skew.

$$\begin{aligned}
 t_{cd_LE} &= t_{pd_LE} = 381 \text{ ps} \\
 t_{cd} &= t_{cd_LE} + t_{wire} = 627 \text{ ps}
 \end{aligned}$$

$$\begin{aligned}t_{\text{skew}} &< (t_{ccq} + t_{cd}) - t_{\text{hold}} \\ &< [(199 + 627) - 0] \text{ ps} \\ &< \mathbf{826 \text{ ps}}\end{aligned}$$

3 ns is less than 826 ps, so there is no hold time violation.
Now we find the fastest frequency at which it can run.

$$\begin{aligned}T_c &\geq t_{pcq} + t_{pd} + t_{\text{setup}} + t_{\text{skew}} \\ &\geq [0.902 + 3] \text{ ns} \\ &= 3.902 \text{ ns} \\ f &= 1 / 3.902 \text{ ns} = \mathbf{256 \text{ MHz}}\end{aligned}$$

Exercise 5.59

First, we find the cycle time:

$$T_c = 1/f = 1/100 \text{ MHz} = 10 \text{ ns}$$

$$T_c \geq t_{pcq} + Nt_{\text{LE+wire}} + t_{\text{setup}}$$

$$10 \text{ ns} \geq [0.199 + N(0.627) + 0.076] \text{ ns}$$

Thus, $N \leq 15.5$

The maximum number of LEs on the critical path is **15**.

With at most one LE on the critical path and no clock skew, the fastest the FSM will run is:

$$T_c \geq [0.199 + 0.627 + 0.076] \text{ ns}$$

$$\geq 0.902 \text{ ns}$$

$$f = 1 / 0.902 \text{ ns} = \mathbf{1.1 \text{ GHz}}$$

Question 5.1

$$(2^N - 1)(2^N - 1) = 2^{2N} - 2^{N+1} + 1$$

Question 5.3

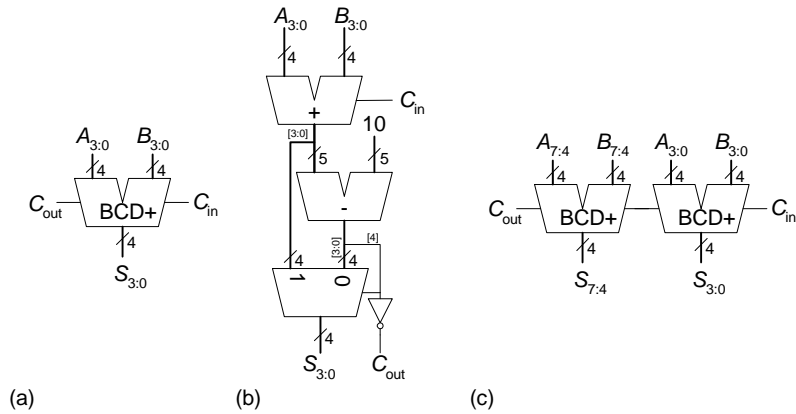

FIGURE 5.10 BCD adder: (a) 4-bit block, (b) underlying hardware, (c) 8-bit BCD adder

(continued from previous page)

SystemVerilog

```

module bcdadd_8(input logic [7:0] a, b,
               input logic cin,
               output logic [7:0] s,
               output logic cout);

    logic c0;

    bcdadd_4 bcd0(a[3:0], b[3:0], cin, s[3:0], c0);
    bcdadd_4 bcd1(a[7:4], b[7:4], c0, s[7:4], cout);

endmodule

module bcdadd_4(input logic [3:0] a, b,
               input logic cin,
               output logic [3:0] s,
               output logic cout);

    logic [4:0] result, sub10;

    assign result = a + b + cin;
    assign sub10 = result - 10;

    assign cout = ~sub10[4];
    assign s = sub10[4] ? result[3:0] : sub10[3:0];

endmodule
    
```

VHDL

```

library IEEE; use IEEE.STD_LOGIC_1164.all;

entity bcdadd_8 is
    port(a, b: in STD_LOGIC_VECTOR(7 downto 0);
          cin: in STD_LOGIC;
          s: out STD_LOGIC_VECTOR(7 downto 0);
          cout: out STD_LOGIC);
end;

architecture synth of bcdadd_8 is
    component bcdadd_4
        port(a, b: in STD_LOGIC_VECTOR(3 downto 0);
              cin: in STD_LOGIC;
              s: out STD_LOGIC_VECTOR(3 downto 0);
              cout: out STD_LOGIC);
    end component;
    signal c0: STD_LOGIC;
begin

    bcd0: bcdadd_4
        port map(a(3 downto 0), b(3 downto 0), cin, s(3
        downto 0), c0);
    bcd1: bcdadd_4
        port map(a(7 downto 4), b(7 downto 4), c0, s(7
        downto 4), cout);

end;

library IEEE; use IEEE.STD_LOGIC_1164.all;
use IEEE.STD_LOGIC_UNSIGNED.all;
use IEEE.STD_LOGIC_ARITH.all;

entity bcdadd_4 is
    port(a, b: in STD_LOGIC_VECTOR(3 downto 0);
          cin: in STD_LOGIC;
          s: out STD_LOGIC_VECTOR(3 downto 0);
          cout: out STD_LOGIC);
end;

architecture synth of bcdadd_4 is
    signal result, sub10, a5, b5: STD_LOGIC_VECTOR(4
    downto 0);
begin
    a5 <= '0' & a;
    b5 <= '0' & b;
    result <= a5 + b5 + cin;
    sub10 <= result - "01010";

    cout <= not (sub10(4));
    s <= result(3 downto 0) when sub10(4) = '1'
        else sub10(3 downto 0);

end;
    
```

CHAPTER 6

Exercise 6.1

(1) Simplicity favors regularity:

- Each instruction has a 6-bit opcode.
- MIPS has only 3 instruction formats (R-Type, I-Type, J-Type).
- Each instruction format has the same number and order of operands (they differ only in the opcode).
- Each instruction is the same size, making decoding hardware simple.

(2) Make the common case fast.

- Registers make the access to most recently accessed variables fast.
- The RISC (reduced instruction set computer) architecture, makes the common/simple instructions fast because the computer must handle only a small number of simple instructions.
- Most instructions require all 32 bits of an instruction, so all instructions are 32 bits (even though some would have an advantage of a larger instruction size and others a smaller instruction size). The instruction size is chosen to make the common instructions fast.

(3) Smaller is faster.

- The register file has only 32 registers.

- The ISA (instruction set architecture) includes only a small number of commonly used instructions. This keeps the hardware small and, thus, fast.
 - The instruction size is kept small to make instruction fetch fast.
- (4) Good design demands good compromises.
- MIPS uses three instruction formats (instead of just one).
 - Ideally all accesses would be as fast as a register access, but MIPS architecture also supports main memory accesses to allow for a compromise between fast access time and a large amount of memory.
 - Because MIPS is a RISC architecture, it includes only a set of simple instructions, it provides pseudocode to the user and compiler for commonly used operations, like moving data from one register to another (`move`) and loading a 32-bit immediate (`li`).

Exercise 6.3

- (a) $42 \times 4 = 42 \times 2^2 = 101010_2 \ll 2 = 10101000_2 = 0xA8$
 (b) `0xA8` through `0xAB`
 (c)

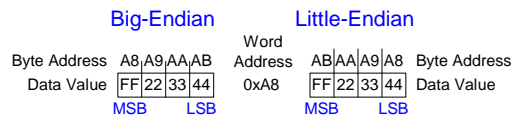

Exercise 6.5

```
# Big-endian
li $t0, 0xABCD9876
sw $t0, 100($0)
lb $s5, 101($0) # the LSB of $s5 = 0xCD

# Little-endian
li $t0, 0xABCD9876
sw $t0, 100($0)
lb $s5, 101($0) # the LSB of $s5 = 0x98
```

In big-endian format, the bytes are numbered from 100 to 103 from left to right. In little-endian format, the bytes are numbered from 100 to 103 from right to left. Thus, the final load byte (`lb`) instruction returns a different value depending on the endianness of the machine.

Exercise 6.7

- (a) 0x68 6F 77 64 79 00
- (b) 0x6C 69 6F 6E 73 00
- (c) 0x54 6F 20 74 68 65 20 72 65 73 63 75 65 21 00

Exercise 6.9

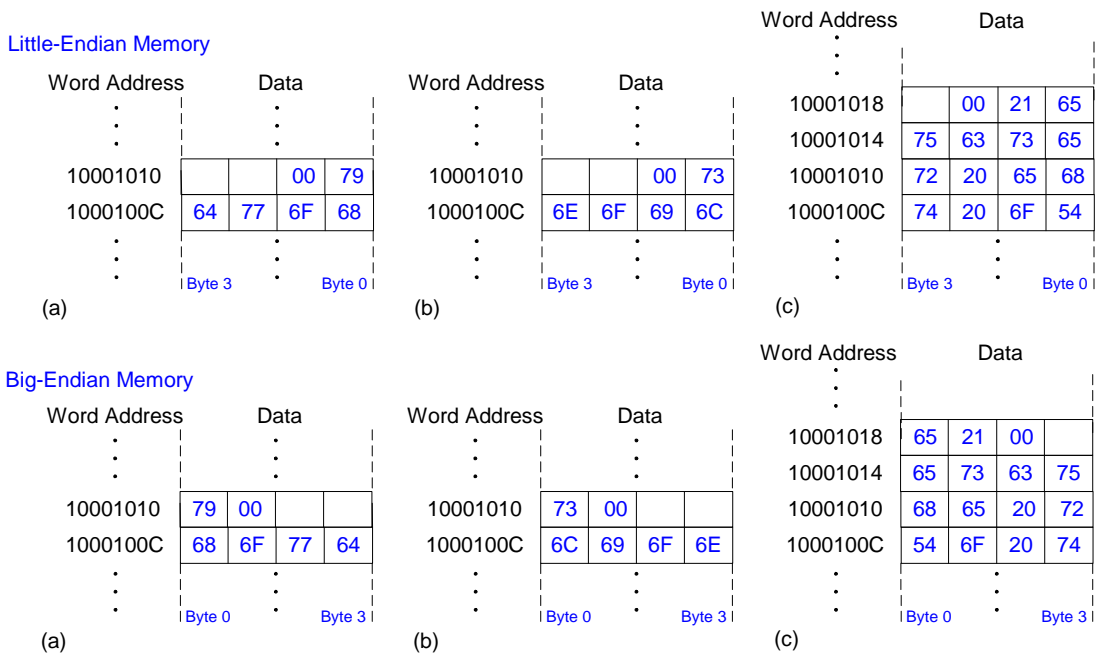

Exercise 6.11

- 0x20100049
- 0xad49fff9
- 0x02f24822

Exercise 6.13

- (a)

```
addi $s0, $0, 73
sw    $t1, -7($t2)
```

(b)
0x20100049 (addi)
0xad49fff9 (sw)

Exercise 6.15

```
    addi $t0, $0, 31
L1:  srlv $t1, $a0, $t0
     andi $t1, $t1, 1
     slt $t1, $0, $t1
     sb $t1, 0($a1)
     addi $a1, $a1, 1
     addi $t0, $t0, -1
     bgez $t0, L1
     jr $ra
```

(a) This program converts a number (\$a0) from decimal to binary and stores it in an array pointed to by \$a1.

```
void convert2bin(int num, char binarray[])
{
    int i;
    char tmp, val = 31;

    for (i=0; i<32; i++) {
        tmp = (num >> val) & 1;
        binarray[i] = tmp;
        val--;
    }
}
```

Exercise 6.17

(a)

```
# $s0 = g, $s1 = h
slt $t0, $s1, $s0      # if h < g, $t0 = 1
beq $t0, $0, else     # if $t0 == 0, do else
add $s0, $s0, $s1     # g = g + h
j done                # jump past else block
else:sub $s0, $s0, $s1 # g = g - h
done:
```

(b)

```
slt  $t0, $s0, $s1 # if g < h, $t0 = 1
bne  $t0, $0, else # if $t0 != 0, do else
addi $s0, $s0, 1   # g = g + 1
j    done          # jump past else block
else: addi $s1, $s1, -1 # h = h - 1
done:
```

(c)

```
slt $t0, $s1, $s0 # if h < g, $t0 = 1
bne $t0, $0, else # if $t0 != 0, do else
add $s0, $0, $0   # g = 0
j   done          # jump past else block
else: sub $s1, $0, $0 # h = 0
done:
```

Exercise 6.19

(a)

```
# MIPS assembly code
# base address of array dst = $a0
# base address of array src = $a1
# i = $s0

strcpy:
    addi $sp, $sp, -4
    sw   $s0, 0($sp) # save $s0 on the stack
    add  $s0, $0, $0 # i = 0

loop:
    add  $t1, $a1, $s0 # $t1 = address of src[i]
    lb   $t2, 0($t1)  # $t2 = src[i]
    add  $t3, $a0, $s0 # $t3 = address of dst[i]
    sb   $t2, 0($t3)  # dst[i] = src[i]
    beq  $t2, $0, done # check for null character
    addi $s0, $s0, 1  # i++
    j    loop

done:
    lw   $s0, 0($sp) # restore $s0 from stack
    addi $sp, $sp, 4 # restore stack pointer
    jr   $ra         # return
```

(b) The stack (i) before, (ii) during, and (iii) after the `strcpy` procedure call.

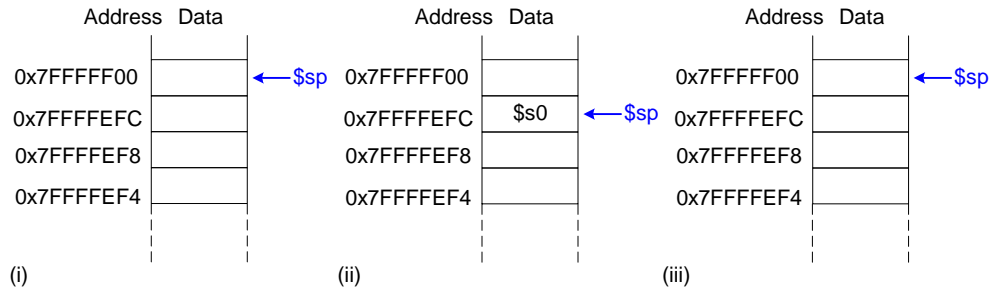

Exercise 6.21

(a) The stack frames of each procedure are:
 proc1: 3 words deep (for `$s0 - $s1, $ra`)
 proc2: 7 words deep (for `$s2 - $s7, $ra`)
 proc3: 4 words deep (for `$s1 - $s3, $ra`)
 proc4: 0 words deep (doesn't use any saved registers or call other procedures)

(b) Note: we arbitrarily chose to make the initial value of the stack pointer 0x7FFFFFF04 just before the procedure calls.

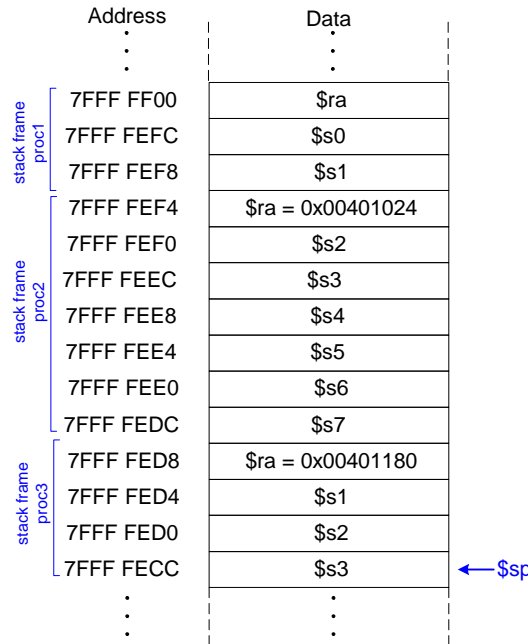

Exercise 6.23

- (a) 120
- (b) 2
- (c)
 - (i) 3 - returned value is 1
 - (ii) 2 (depending on what's stored on the stack frame of the callee's stack)
 - (iii) 4

Exercise 6.25

- (a) 000100 01000 10001 0000 0000 0000 0010
 = **0x11110002**
- (b) 000100 01111 10100 0000 0100 0000 1111
 = **0x11F4040F**
- (c) 000100 11001 10111 1111 1000 0100 0010
 = **0x1337F842**
- (d) 000011 0000 0100 0001 0001 0100 0111 11
 = **0x0C10451F**

(e) 000010 00 0001 0000 0000 1100 0000 0001
= **0x08100C01**

Exercise 6.27

(a)

```
set_array:  addi $sp,$sp,-52  # move stack pointer
            sw  $ra,48($sp) # save return address
            sw  $s0,44($sp) # save $s0
            sw  $s1,40($sp) # save $s1

            add $s0,$0,$0  # i = 0
            addi $s1,$0,10 # max iterations = 10
loop:      add $a1,$s0,$0  # pass i as parameter
            jal compare    # call compare(num, i)
            sll $t1,$s0,2  # $t1 = i*4
            add $t2,$sp,$t1 # $t2 = address of array[i]
            sw  $v0,0($t2)  # array[i] = compare(num, i);
            addi $s0,$s0,1  # i++
            bne $s0,$s1,loop # if i<10, goto loop

            lw  $s1,40($sp) # restore $s1
            lw  $s0,44($sp) # restore $s0
            lw  $ra,48($sp) # restore return address
            addi $sp,$sp,52 # restore stack pointer
            jr  $ra        # return to point of call

compare:   addi $sp,$sp,-4  # move stack pointer
            sw  $ra,0($sp)  # save return address on the stack
            jal subtract    # input parameters already in $a0,$a1
            slt $v0,$v0,$0  # $v0=1 if sub(a,b) < 0 (return 0)
            slti $v0,$v0,1  # $v0=1 if sub(a,b)>=0, else $v0 = 0
            lw  $ra,0($sp)  # restore return address
            addi $sp,$sp,4  # restore stack pointer
            jr  $ra        # return to point of call

subtract:  sub  $v0,$a0,$a1  # return a-b
            jr  $ra        # return to point of call
```

6.27 (b)

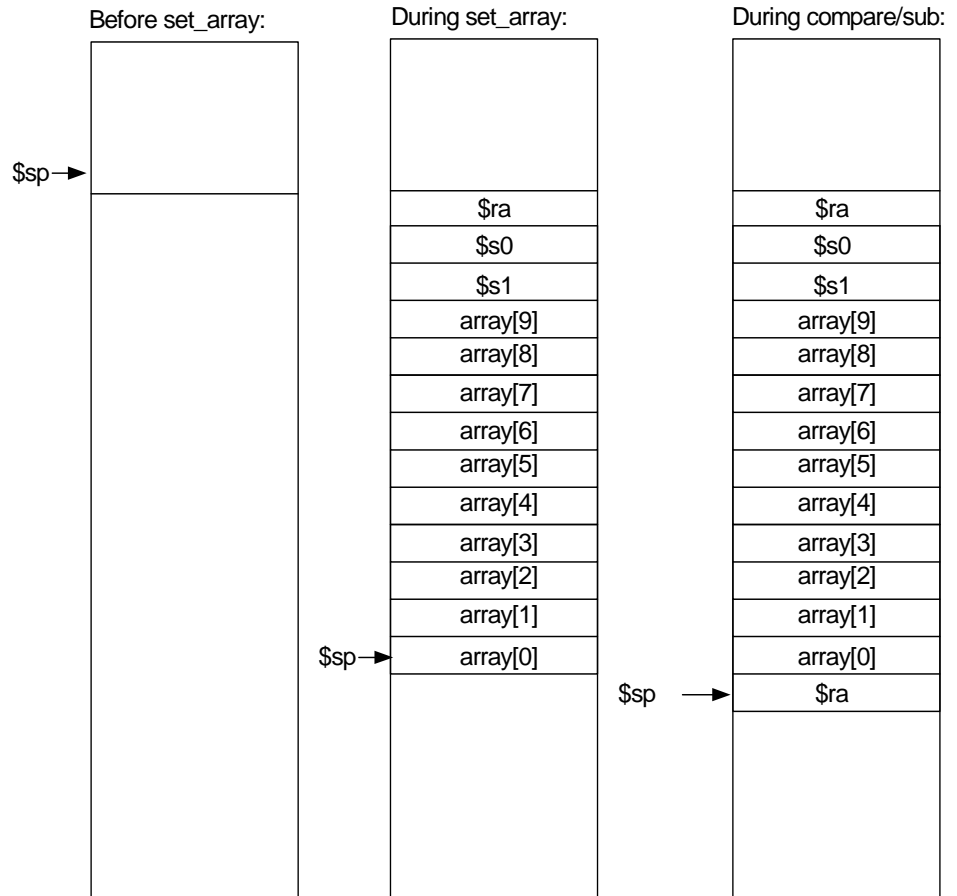

(c) If $\$ra$ were never stored on the stack, the compare function would return to the instruction after the call to `subtract (slt $v0, $v0, $0)` instead of returning to the `set_array` function. The program would enter an infinite loop in the `compare` function between `jr $ra` and `slt $v0, $v0, $0`. It would increment the stack during that loop until the stack space was exceeded and the program would likely crash.

Exercise 6.29

Instructions (32 K - 1) words before the branch to instructions 32 K words after the branch instruction.

Exercise 6.31

It is advantageous to have a large address field in the machine format for jump instructions to increase the range of instruction addresses to which the instruction can jump.

Exercise 6.33

```
# high-level code
void little2big(int[] array)
{
    int i;

    for (i = 0; i < 10; i = i + 1) {
        array[i] = ((array[i] & 0xFF) << 24) ||
            (array[i] & 0xFF00) << 8) ||
            (array[i] & 0xFF0000) >> 8) ||
            ((array[i] >> 24) & 0xFF));
    }
}

# MIPS assembly code
# $a0 = base address of array
little2big:
    addi $t5, $0, 10 # $t5 = i = 10 (loop counter)
loop:   lb  $t0, 0($a0) # $t0 = array[i] byte 0
        lb  $t1, 1($a0) # $t1 = array[i] byte 1
        lb  $t2, 2($a0) # $t2 = array[i] byte 2
        lb  $t3, 3($a0) # $t3 = array[i] byte 3
        sb  $t3, 0($a0) # array[i] byte 0 = previous byte 3
        sb  $t2, 1($a0) # array[i] byte 1 = previous byte 2
        sb  $t1, 2($a0) # array[i] byte 2 = previous byte 1
        sb  $t0, 3($a0) # array[i] byte 3 = previous byte 0
        addi $a0, $a0, 4 # increment index into array
        addi $t5, $t5, -1 # decrement loop counter
        beq $t5, $0, done
        j   loop
done:
```

Exercise 6.35

```
# define the masks in the global data segment
.data
mmask: .word 0x007FFFFFFF
emask: .word 0x7F800000
ibit:  .word 0x00800000
obit:  .word 0x01000000

.text

flpadd: lw $t4,mmask           # load mantissa mask
        and $t0,$s0,$t4       # extract mantissa from $s0 (a)
        and $t1,$s1,$t4       # extract mantissa from $s1 (b)
        lw $t4,ibit           # load implicit leading 1
        or $t0,$t0,$t4        # add the implicit leading 1 to mantissa
        or $t1,$t1,$t4        # add the implicit leading 1 to mantissa
```



```

        lw $t4,emask           # load exponent mask
        and $t2,$s0,$t4       # extract exponent from $s0 (a)
        srl $t2,$t2,23        # shift exponent right
        and $t3,$s1,$t4       # extract exponent from $s1 (b)
        srl $t3,$t3,23        # shift exponent right
match:   beq $t2,$t3,addsig    # check whether the exponents match
        bgeu $t2,$t3,shiftb   # determine which exponent is larger
shifta:  sub $t4,$t3,shiftb   # calculate difference in exponents
        srav $t0,$t0,$t4      # shift a by calculated difference
        add $t2,$t2,$t4       # update a's exponent
        j addsig              # skip to the add
shiftb:  sub $t4,$t2,$t3      # calculate difference in exponents
        srav $t1,$t1,$t4      # shift b by calculated difference
        add $t3,$t3,$t4       # update b's exponent (not necessary)
addsig:  add $t5,$t0,$t1      # add the mantissas
norm:   lw $t4,obit          # load mask for bit 24 (overflow bit)
        and $t4,$t5,$t4       # mask bit 24
        beq $t4,$0,done       # right shift not needed because bit 24=0
        srl $t5,$t5,1         # shift right once by 1 bit
        addi $t2,$t2,1        # increment exponent
done:    lw $t4,mmask         # load mask
        and $t5,$t5,$t4       # mask mantissa
        sll $t2,$t2,23        # shift exponent into place
        lw $t4,emask         # load mask
        and $t2,$t2,$t4       # mask exponent
        or $v0,$t5,$t2       # place mantissa and exponent into $v0
        jr $ra                # return to caller
    
```

Exercise 6.37

(a)

```

0x00400000 main:   addi $sp, $sp, -4
0x00400004         sw   $ra, 0($sp)
0x00400008         addi $t0, $0, 15
0x0040000C         sw   $t0, 0x8000($gp)
0x00400010         addi $a1, $0, 27
0x00400014         sw   $a1, 0x8004($gp)
0x00400018         lw   $a0, 0x8000($gp)
0x0040001C         jal  greater
0x00400020         lw   $ra, 0($sp)
0x00400024         addi $sp, $sp, 4
0x00400028         jr   $ra

0x0040002C greater: slt  $v0, $a1, $a0
0x00400030         jr   $ra
    
```

(b)

symbol	address
a	0x10000000
b	0x10000004
main	0x00400000
greater	0x0040002C

TABLE 6.1 Symbol table

(c)

Executable file header	Text Size	Data Size
	0x34 (52 bytes)	0x8 (8 bytes)
Text segment	Address	Instruction
	0x00400000	0x23BDFFFC
	0x00400004	0xAFBF0000
	0x00400008	0x2008000F
	0x0040000C	0xAF888000
	0x00400010	0x2005001B
	0x00400014	0xAF858004
	0x00400018	0x8F848000
	0x0040001C	0x0C10000B
	0x00400020	0x8FBF0000
	0x00400024	0x23BD0004
	0x00400028	0x03E00008
	0x0040002C	0x00A4102A
	0x00400030	0x03E00008
Data segment	Address	Data
	0x10000000	a
	0x10000004	b

```

addi $sp, $sp, -4
sw $ra, 0($sp)
addi $t0, $0, 15
sw $t0, 0x8000($gp)
addi $a1, $0, 27
sw $a1, 0x8004($gp)
lw $a0, 0x8000($gp)
jal greater
lw $ra, 0($sp)
addi $sp, $sp, 4
jr $ra
slt $v0, $a1, $a0
jr $ra
    
```

(d)

The data segment is 8 bytes and the text segment is 52 (0x34) bytes.

(e)

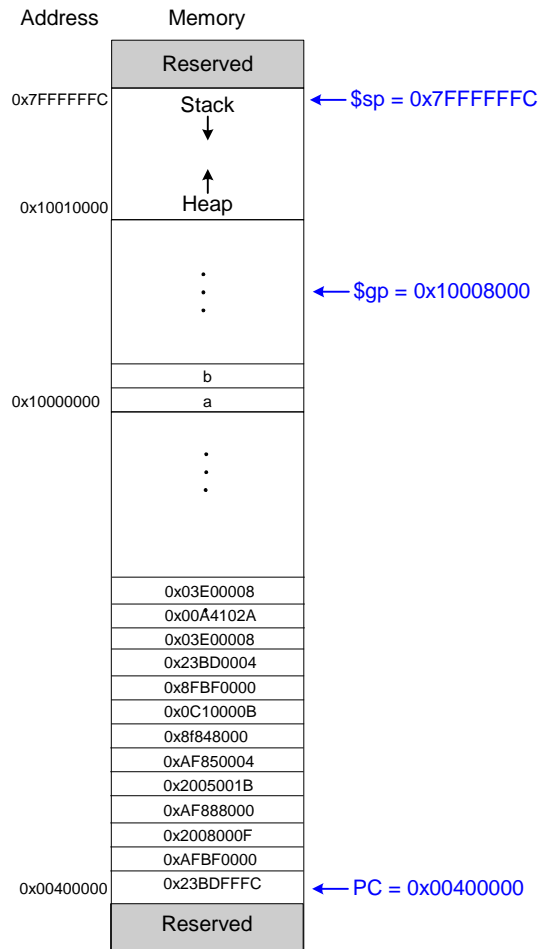

Exercise 6.39

(a)

```
beq $t1, imm31:0, L

lui $at, imm31:16
ori $at, $at, imm15:0
beq $t1, $at, L
```

(b)

```
ble $t3, $t5, L

slt $at, $t5, $t3
beq $at, $0, L
```

(c)

```
bgt $t3, $t5, L
```

```
slt $at, $t5, $t3
```

```
bne $at, $0, L
```

(d)

```
bge $t3, $t5, L
```

```
slt $at, $t3, $t5
```

```
beq $at, $0, L
```

Question 6.1

```
xor $t0, $t0, $t1 # $t0 = $t0 XOR $t1  
xor $t1, $t0, $t1 # $t1 = original value of $t0  
xor $t0, $t0, $t1 # $t0 = original value of $t1
```

Question 6.3

High-Level Code

```

// high-level algorithm
void reversewords(char[] array) {
    int i, j, length;

    // find length of string
    for (i = 0; array[i] != 0; i = i + 1) ;

    length = i;

    // reverse characters in string
    reverse(array, length-1, 0);

    // reverse words in string
    i = 0; j = 0;

    // check for spaces
    while (i <= length) {
        if ( (i != length) || (array[i] != 0x20) ) {
            i = i + 1;

        } else {
            reverse(array, i-1, j);
            i = i + 1; // j and i at start of next word
            j = i;
        }
    }
}

void reverse(char[] array, int i, int j)
{
    char tmp;
    while (i > j) {
        tmp = array[i];
        array[i] = array[j];
        array[j] = tmp;
        i = i-1;
        j = j+1;
    }
}

```

MIPS Assembly Code

```

# $s2 = i, $s3 = j, $s1 = length
reversewords:
    addi $sp, $sp, -16 # make room on stack
    sw   $ra, 12($sp) # store regs on stack
    sw   $s1, 8($sp)
    sw   $s2, 4($sp)
    sw   $s3, 0($sp)

    addi $s2, $0, 0 # i = 0
length:   add  $t4, $a0, $s2 # $t4 = &array[i]
          lb  $t3, 0($t4) # $t3 = array[i]
          beq $t3, $0, done # end of string?
          addi $s2, $s2, 1 # i++
          j   length

done:     addi $s1, $s2, 0 # length = i
          addi $a1, $s1, -1 # $a1 = length - 1
          addi $a2, $0, 0 # $a2 = 0
          jal reverse # call reverse

          addi $s2, $0, 0 # i = 0
          addi $s3, $0, 0 # j = 0
          addi $t5, $0, 0x20 # $t5 = "space"
word:    slt  $t4, $s1, $s2 # $t4 = 1 if length<i
          bne $t4, $0, return # return if length<i
          beq $s2, $s1, else # if i==length, else
          add $t4, $a0, $s2 # $t4 = &array[i]
          lb  $t4, 0($t4) # $t4 = array[i]
          beq $t4, $t5, else # if $t4==0x20,else
          addi $s2, $s2, 1 # i = i + 1
          j   word
else:    addi $a1, $s2, -1 # $a1 = i - 1
          addi $a2, $s3, 0 # $a2 = j
          jal reverse
          addi $s2, $s2, 1 # i = i + 1
          addi $s3, $s2, 0 # j = i
          j   word

return:  lw   $ra, 12($sp) # restore regs
          lw   $s1, 8($sp)
          lw   $s2, 4($sp)
          lw   $s3, 0($sp)
          addi $sp, $sp, 16 # restore $sp
          jr   $ra # return

reverse:
    slt  $t0, $a2, $a1 # $t0 = 1 if j < i
    beq  $t0, $0, exit # if j < i, return
    add  $t1, $a0, $a1 # $t1 = &array[i]
    lb  $t2, 0($t1) # $t2 = array[i]
    add  $t3, $a0, $a2 # $t3 = &array[j]
    lb  $t4, 0($t3) # $t4 = array[j]
    sb  $t4, 0($t1) # array[i] =array[j]
    sb  $t2, 0($t3) # array[j] =array[i]
    addi $a1, $a1, -1 # i = i-1
    addi $a2, $a2, 1 # j = j+1
    j   reverse
exit:   jr   $ra

```

Question 6.5**High-Level Code**

```

num = swap(num, 1, 0x55555555); // swap bits
num = swap(num, 2, 0x33333333); // swap pairs
num = swap(num, 4, 0x0F0F0F0F); // swap nibbles
num = swap(num, 8, 0x00FF00FF); // swap bytes
num = swap(num, 16, 0xFFFFFFFF); // swap halves

// swap masked bits
int swap(int num, int shamt, unsigned int mask) {
    return ((num >> shamt) & mask) |
        ((num & mask) << shamt);
}

```

MIPS Assembly Code

```

# $t3 = num
addi $a0, $t3, 0 # set up args
addi $a1, $0, 1
li $a2, 0x55555555
jal swap # swap bits
addi $a0, $v0, 0 # num = return value

addi $a1, $0, 2 # set up args
li $a2, 0x33333333
jal swap # swap pairs
addi $a0, $v0, 0 # num = return value

addi $a1, $0, 4 # set up args
li $a2, 0x0F0F0F0F
jal swap # swap nibbles
addi $a0, $v0, 0 # num = return value

addi $a1, $0, 8 # set up args
li $a2, 0x00FF00FF
jal swap # swap bytes
addi $a0, $v0, 0 # num = return value

addi $a1, $0, 16 # set up args
li $a2, 0xFFFFFFFF
jal swap # swap halves
addi $t3, $v0, 0 # num = return value

done: j done

swap:
    srlv $v0, $a0, $a1 # $v0 = num >> shamt
    and $v0, $v0, $a2 # $v0 = $v0 & mask
    and $t0, $a0, $a2 # $t0 = num & mask
    sllv $t0, $t0, $a1 # $t0 = $t0 << shamt
    or $v0, $v0, $t0 # $v0 = $v0 | $t0
    jr $ra # return

```

Question 6.7

High-Level Code

```
bool palindrome(char* array) {
    int i, j; // array indices
    // find length of string
    for (j = 0; array[j] != 0; j=j+1) ;

    j = j-1; // j is index of last char

    int i = 0;
    while (j > i) {
        tmp = array[i];
        if (array[i] != array[j])
            return false;
        j = j-1;
        i = i+1;
    }

    return true;
}
```

MIPS Assembly Code

```
# $t0 = j, $t1 = i, $a0 = base address of string
palindrome:
    addi $t0, $0, 0      # j = 0
length:   add $t2, $a0, $t0 # $t2 = &array[j]
          lb  $t2, 0($t2)  # $t2 = array[j]
          beq $t2, $0, done # end of string?
          addi $t0, $t0, 1 # j = j+1
          j   length
done:     addi $t0, $t0, -1 # j = j-1

          addi $t1, $0, 0   # i = 0
loop:    slt $t2, $t1, $t0 # $t2 = 1 if i < j
          beq $t2, $0, yes  # if !(i < j) return
          add $t2, $a0, $t1 # $t2 = &array[i]
          lb  $t2, 0($t2)  # $t2 = array[i]
          add $t3, $a0, $t0 # $t3 = &array[j]
          lb  $t3, 0($t3)  # $t3 = array[j]
          bne $t2, $t3, no  # is palindrome?
          addi $t0, $t0, -1 # j = j-1
          addi $t1, $t1, 1  # i = i+1
          j   loop

yes:     # yes a palindrome
          addi $v0, $0, 1
          j   yes
          jr  $ra

no:      # not a palindrome
          addi $v0, $0, 0
          j   no
          jr  $ra
```

CHAPTER 7

Exercise 7.1

- (a) R-type, lw, addi
- (b) R-type
- (c) sw

Exercise 7.3

- (a) sll

First, we modify the ALU.

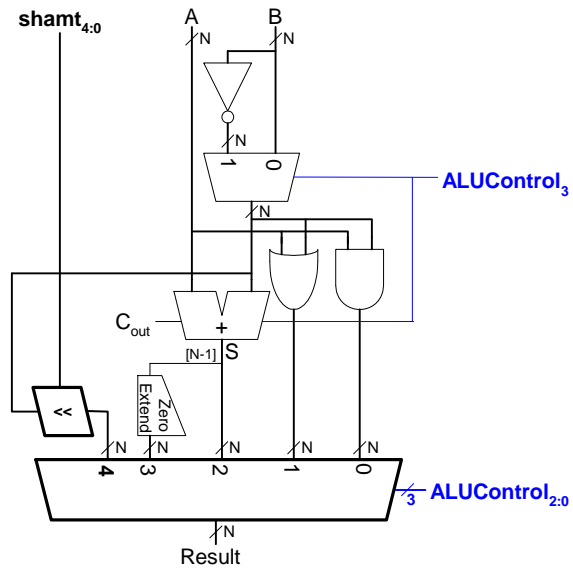

FIGURE 7.1 Modified ALU to support sll

ALUControl _{3:0}	Function
0000	A AND B
0001	A OR B
0010	A + B
0011	not used
1000	A AND \bar{B}
1001	A OR \bar{B}
1010	A - B
1011	SLT
0100	SLL

TABLE 7.1 Modified ALU operations to support sll

ALUOp	Funct	ALUControl
00	X	0010 (add)
X1	X	1010 (subtract)
1X	100000 (add)	0010 (add)
1X	100010 (sub)	1010 (subtract)
1X	100100 (and)	0000 (and)
1X	100101 (or)	0001 (or)
1X	101010 (slt)	1011 (set less than)
1X	000000 (sll)	0100 (shift left logical)

TABLE 7.2 ALU decoder truth table

Then we modify the datapath.

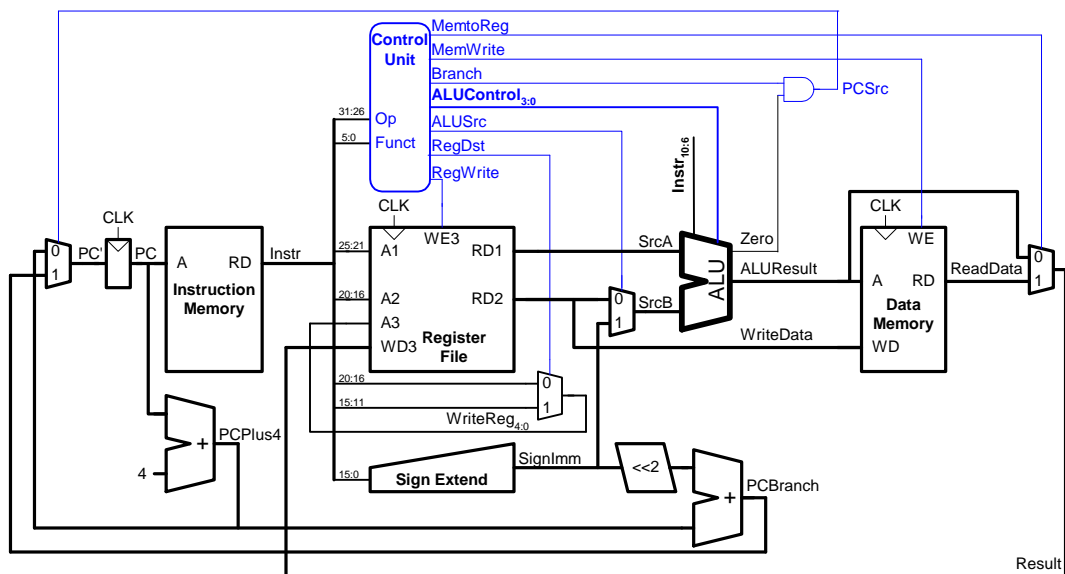

FIGURE 7.2 Modified single-cycle MIPS processor extended to run sll

7.3 (b) lui

Note: the 5-bit rs field of the lui instruction is 0.

Instruction	opcode	RegWrite	RegDst	ALUSrc	Branch	MemWrite	MemtoReg	ALUOp
R-type	000000	1	1	00	0	0	0	10
lw	100011	1	0	01	0	0	1	00
sw	101011	0	X	01	0	1	X	00
beq	000100	0	X	00	1	0	X	01
lui	001111	1	0	10	0	0	0	00

TABLE 7.3 Main decoder truth table enhanced to support lui

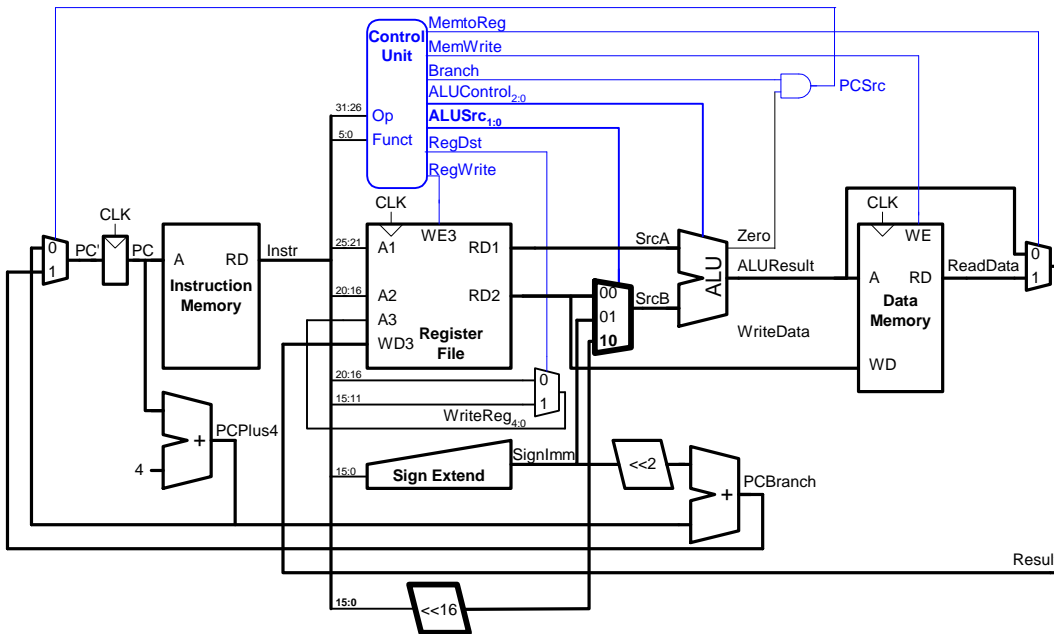

FIGURE 7.3 Modified single-cycle datapath to support lui

7.3 (c) `slti`

The datapath doesn't change. Only the controller changes, as shown in Table 7.4 and Table 7.5.

ALUOp	Funct	ALUControl
00	X	010 (add)
01	X	110 (subtract)
10	100000 (add)	010 (add)
10	100010 (sub)	110 (subtract)
10	100100 (and)	000 (and)
10	100101 (or)	001 (or)
10	101010 (slt)	111 (set less than)
11	X	111 (set less than)

TABLE 7.4 ALU decoder truth table

Instruction	opcode	RegWrite	RegDst	ALUSrc	Branch	MemWrite	MemtoReg	ALUOp
R-type	000000	1	1	0	0	0	0	10
lw	100011	1	0	1	0	0	1	00
sw	101011	0	X	1	0	1	X	00
beq	000100	0	X	0	1	0	X	01
slti	001010	1	0	1	0	0	0	11

TABLE 7.5 Main decoder truth table enhanced to support `slti`

7.3 (d) blez

First, we modify the ALU

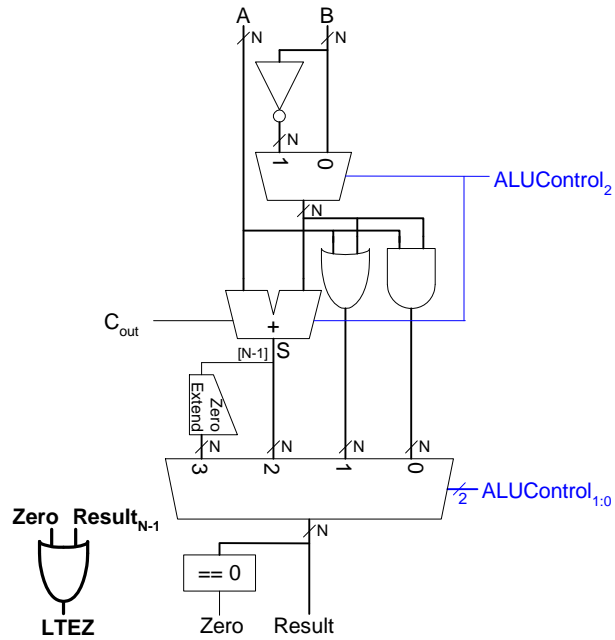

Then, we modify the datapath

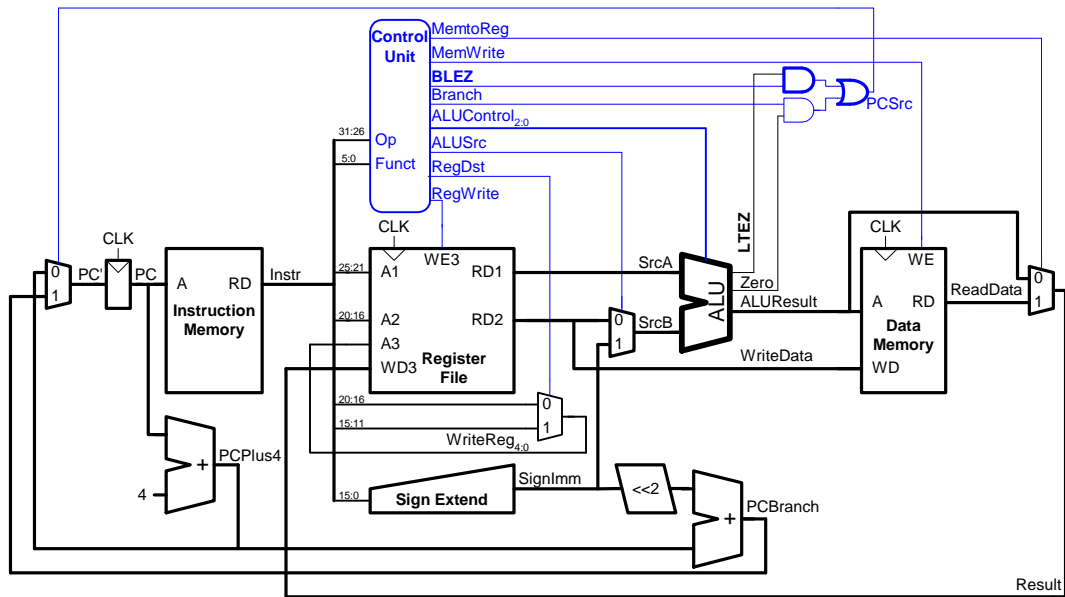

Instruction	opcode	RegWrite	RegDst	ALUSrc	Branch	MemWrite	MemtoReg	ALUOp	BLEZ
R-type	000000	1	1	0	0	0	0	10	0
lw	100011	1	0	1	0	0	1	00	0
sw	101011	0	X	1	0	1	X	00	0
beq	000100	0	X	0	1	0	X	01	0
blez	000110	0	X	0	0	0	X	01	1

TABLE 7.6 Main decoder truth table enhanced to support `blez`

Exercise 7.5

It is not possible to implement this instruction without either modifying the register file (adding another write port) or making the instruction take two cycles to execute.

We modify the register file and datapath as shown in Figure 7.4.

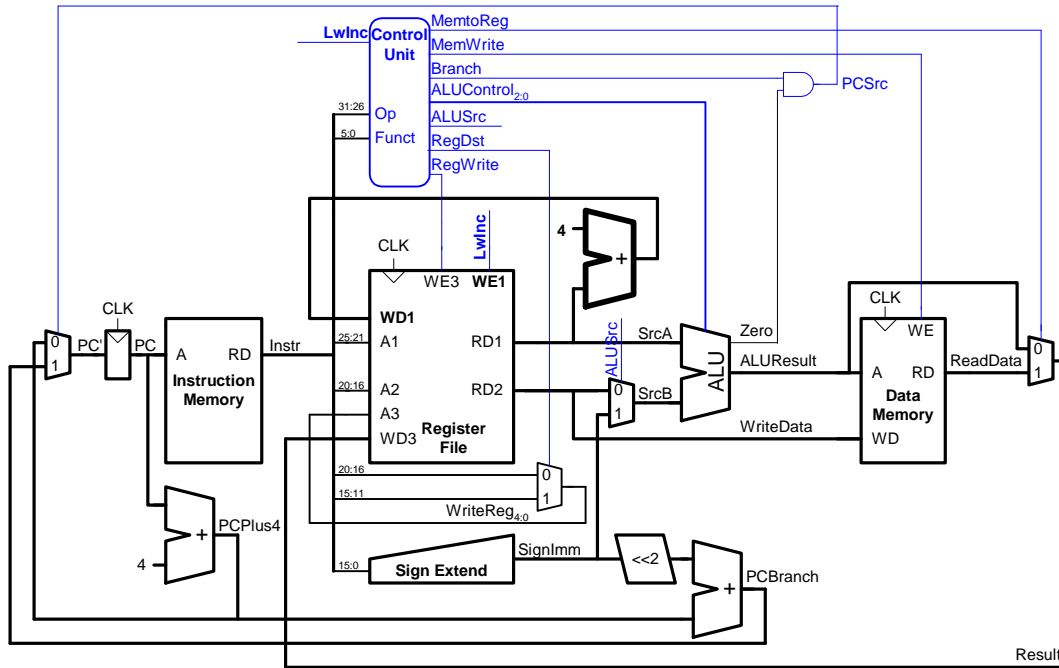

FIGURE 7.4 Modified datapath

Instruction	opcode	RegWrite	RegDst	ALUSrc	Branch	MemWrite	MemtoReg	ALUOp	Lwinc
R-type	000000	1	1	0	0	0	0	10	0
lw	100011	1	0	1	0	0	1	00	0
sw	101011	0	X	1	0	1	X	00	0
beq	000100	0	X	0	1	0	X	01	0
lwinc		1	0	1	0	0	1	00	1

TABLE 7.7 Main decoder truth table enhanced to support lwinc

Exercise 7.7

Before the enhancement (see Equation 7.3, page 380 in the text, also Errata):

$$T_c = t_{pcq_PC} + 2t_{mem} + t_{RFread} + t_{mux} + t_{ALU} + t_{RFsetup}$$
$$= 30 + 2(250) + 150 + 25 + 200 + 20 = \mathbf{925ps}$$

The unit that your friend could speed up that would make the largest reduction in cycle time would be the memory unit. So $t_{mem_new} = 125ps$, and the new cycle time is:

$$T_c = \mathbf{675 ps}$$

Exercise 7.9

- (a) lw
- (b) beq
- (c) beq, j

Exercise 7.11

SystemVerilog

```
module top(input logic clk, reset,
           output logic [31:0] writedata, dataadr,
           output logic memwrite);

    logic [31:0] pc, instr, readdata;

    // instantiate processor and memories
    mips mips(clk, reset, pc, instr, memwrite, dataadr,
             writedata, readdata);
    imem imem(pc[7:2], instr);
    dmem dmem(clk, memwrite, dataadr, writedata, readdata);
endmodule

module dmem(input logic clk, we,
            input logic [31:0] a, wd,
            output logic [31:0] rd);

    logic [31:0] RAM[63:0];

    assign rd = RAM[a[31:2]]; // word aligned

    always_ff @(posedge clk)
        if (we) RAM[a[31:2]] <= wd;
endmodule

module imem(input logic [5:0] a,
```

```
        output logic [31:0] rd);

    logic [31:0] RAM[63:0];

    initial
        $readmemh("memfile.dat",RAM);

    assign rd = RAM[a]; // word aligned
endmodule

module mipssingle(input  logic      clk, reset,
                 output logic [31:0] pc,
                 input  logic [31:0] instr,
                 output logic      memwrite,
                 output logic [31:0] aluresult,
                 output logic [31:0] writedata,
                 input  logic [31:0] readdata);

    logic      memtoreg;
    logic [1:0] alusrc; // LUI
    logic      regdst;
    logic      regwrite, jump, pcsrc, zero;
    logic [3:0] alucontrol; // SLL
    logic      ltez; // BLEZ

    controller c(instr[31:26], instr[5:0], zero,
                memtoreg, memwrite, pcsrc,
                alusrc, regdst, regwrite, jump,
                alucontrol,
                ltez); // BLEZ

    datapath dp(clk, reset, memtoreg, pcsrc,
                alusrc, regdst, regwrite, jump,
                alucontrol,
                zero, pc, instr,
                aluresult, writedata, readdata,
                ltez); // BLEZ
endmodule

module controller(input  logic [5:0] op, funct,
                 input  logic      zero,
                 output logic      memtoreg, memwrite,
                 output logic      pcsrc,
                 output logic [1:0] alusrc, // LUI
                 output logic      regdst,
                 output logic      regwrite,
                 output logic      jump,
                 output logic [3:0] alucontrol, // SLL
                 input  logic      ltez); // BLEZ

    logic [1:0] aluop;
```

```
logic      branch;
logic      blez; // BLEZ

maindec md(op, memtoreg, memwrite, branch,
           alusrc, regdst, regwrite, jump,
           aluop, blez); // BLEZ
aludec ad(funcnt, aluop, alucontrol);

// BLEZ
assign pcsrc = (branch & zero) | (blez & ltez);

endmodule

module maindec(input  logic [5:0] op,
              output logic   memtoreg, memwrite,
              output logic   branch,
              output logic [1:0] alusrc, // LUI
              output logic   regdst,
              output logic   regwrite,
              output logic   jump,
              output logic [1:0] aluop,
              output logic   blez); // BLEZ

// increase control width for LUI, BLEZ
logic [10:0] controls;

assign {regwrite, regdst, alusrc, branch, memwrite,
       memtoreg, aluop, jump, blez} = controls;

always_comb
case(op)
6'b000000: controls = 11'b11000001000; //Rtype
6'b100011: controls = 11'b10010010000; //LW
6'b101011: controls = 11'b00010100000; //SW
6'b000100: controls = 11'b00001000100; //BEQ
6'b001000: controls = 11'b10010000000; //ADDI
6'b000010: controls = 11'b00000000010; //J
6'b001010: controls = 11'b10010001100; //SLTI
6'b001111: controls = 11'b10100000000; //LUI
6'b000110: controls = 11'b00000000101; //BLEZ
default:   controls = 11'bxxxxxxxxxxx; //???
endcase
endmodule

module aludec(input  logic [5:0] funcnt,
             input  logic [1:0] aluop,
             output logic [3:0] alucontrol);
// increase to 4 bits for SLL

always_comb
case(aluop)
2'b00: alucontrol = 4'b0010; // add
2'b01: alucontrol = 4'b1010; // sub
```

```

        2'b11: alucontrol = 4'b1011; // slt
        default: case(funcnt) // RTYPE
            6'b100000: alucontrol = 4'b0010; // ADD
            6'b100010: alucontrol = 4'b1010; // SUB
            6'b100100: alucontrol = 4'b0000; // AND
            6'b100101: alucontrol = 4'b0001; // OR
            6'b101010: alucontrol = 4'b1011; // SLT
            6'b000000: alucontrol = 4'b0100; // SLL
            default: alucontrol = 4'bxxxx; // ???
        endcase
    endcase
endmodule

module datapath(input logic clk, reset,
               input logic memtoreg, pcsrc,
               input logic [1:0] alusrc, // LUI
               input logic regdst,
               input logic regwrite, jump,
               input logic [3:0] alucontrol, // SLL
               output logic zero,
               output logic [31:0] pc,
               input logic [31:0] instr,
               output logic [31:0] alurestult, writedata,
               input logic [31:0] readdata,
               output logic ltez); // LTEZ

    logic [4:0] writereg;
    logic [31:0] pcnext, pcnextbr, pcplus4, pcbranch;
    logic [31:0] signimm, signimmsh;
    logic [31:0] upperimm; // LUI
    logic [31:0] srca, srcb;
    logic [31:0] result;
    logic [31:0] memdata;

    // next PC logic
    flopr #(32) pcreg(clk, reset, pcnext, pc);
    adder pcadd1(pc, 32'b100, pcplus4);
    sl2 immsh(signimm, signimmsh);
    adder pcadd2(pcplus4, signimmsh, pcbranch);
    mux2 #(32) pcbrmux(pcplus4, pcbranch, pcsrc,
                    pcnextbr);
    mux2 #(32) pcmux(pcnextbr, {pcplus4[31:28],
                               instr[25:0], 2'b00},
                    jump, pcnext);

    // register file logic
    regfile rf(clk, regwrite, instr[25:21],
              instr[20:16], writereg,
              writeresult, srca, writedata);

    mux2 #(5) wrmux(instr[20:16], instr[15:11],
                    regdst, writereg);

```

```
signext    se(instr[15:0], signimm);
upimm      ui(instr[15:0], upperimm); // LUI

// ALU logic
mux3 #(32) srcbmux(writedata, signimm,
                  upperimm, alusrc,
                  srcb); // LUI
alu        alu(srca, srcb, alucontrol,
              instr[10:6], // SLL
              aluresult, zero,
              ltez); // BLEZ
mux2 #(32) rdmux(aluresult, readdata,
                memtoreg, result);

endmodule

// upimm module needed for LUI
module upimm(input logic [15:0] a,
            output logic [31:0] y);

    assign y = {a, 16'b0};
endmodule

// mux3 needed for LUI
module mux3 #(parameter WIDTH = 8)
    (input logic [WIDTH-1:0] d0, d1, d2,
     input logic [1:0] s,
     output logic [WIDTH-1:0] y);

    assign #1 y = s[1] ? d2 : (s[0] ? d1 : d0);
endmodule

module alu(input logic [31:0] A, B,
          input logic [3:0] F,
          input logic [4:0] shamt, // SLL
          output logic [31:0] Y,
          output logic Zero,
          output logic ltez); // BLEZ

    logic [31:0] S, Bout;

    assign Bout = F[3] ? ~B : B;
    assign S = A + Bout + F[3]; // SLL

    always_comb
        case (F[2:0])
            3'b000: Y = A & Bout;
            3'b001: Y = A | Bout;
            3'b010: Y = S;
            3'b011: Y = S[31];
            3'b100: Y = (Bout << shamt); // SLL
        endcase
endmodule
```

```
    assign Zero = (Y == 32'b0);
    assign ltez = Zero | S[31]; // BLEZ

endmodule

module regfile(input  logic      clk,
              input  logic      we3,
              input  logic [4:0] ra1, ra2, wa3,
              input  logic [31:0] wd3,
              output logic [31:0] rd1, rd2);

    logic [31:0] rf[31:0];

    // three ported register file
    // read two ports combinationaly
    // write third port on rising edge of clk
    // register 0 hardwired to 0
    always_ff @(posedge clk)
        if (we3) rf[wa3] <= wd3;

    assign rd1 = (ra1 != 0) ? rf[ra1] : 0;
    assign rd2 = (ra2 != 0) ? rf[ra2] : 0;
endmodule

module adder(input  logic [31:0] a, b,
            output logic [31:0] y);

    assign y = a + b;
endmodule

module sl2(input  logic [31:0] a,
          output logic [31:0] y);

    // shift left by 2
    assign y = {a[29:0], 2'b00};
endmodule

module signext(input  logic [15:0] a,
              output logic [31:0] y);

    assign y = {{16{a[15]}}, a};
endmodule

module flopr #(parameter WIDTH = 8)
            (input  logic      clk, reset,
             input  logic [WIDTH-1:0] d,
             output logic [WIDTH-1:0] q);

    always_ff @(posedge clk, posedge reset)
        if (reset) q <= 0;
        else      q <= d;
endmodule
```

```
endmodule

module mux2 #(parameter WIDTH = 8)
    (input  logic [WIDTH-1:0] d0, d1,
     input  logic             s,
     output logic [WIDTH-1:0] y);

    assign y = s ? d1 : d0;
endmodule
```

VHDL

```
-- mips.vhd

library IEEE;
use IEEE.STD_LOGIC_1164.all; use IEEE.NUMERIC_STD_UN-
SIGNED.all;

entity testbench is
end;

architecture test of testbench is
    component top
        port(clk, reset:          in STD_LOGIC;
             writedata, dataadr:  out STD_LOGIC_VECTOR(31 downto 0);
             memwrite:           out STD_LOGIC);
    end component;
    signal writedata, dataadr:  STD_LOGIC_VECTOR(31 downto 0);
    signal clk, reset, memwrite: STD_LOGIC;
begin

    -- instantiate device to be tested
    dut: top port map(clk, reset, writedata, dataadr, memwrite);

    -- Generate clock with 10 ns period
    process begin
        clk <= '1';
        wait for 5 ns;
        clk <= '0';
        wait for 5 ns;
    end process;

    -- Generate reset for first two clock cycles
    process begin
        reset <= '1';
        wait for 22 ns;
        reset <= '0';
        wait;
    end process;

    -- check that 7 gets written to address 84 at end of program
```

```
        process (clk) begin
            if (clk'event and clk = '0' and memwrite = '1') then
                if (to_integer(dataadr) = 84 and to_integer(writedata) =
7) then
                    report "NO ERRORS: Simulation succeeded" severity fail-
ure;
                elsif (dataadr /= 80) then
                    report "Simulation failed" severity failure;
                end if;
            end if;
        end process;
    end;

    library IEEE;
    use IEEE.STD_LOGIC_1164.all; use IEEE.NUMERIC_STD_UN-
SIGNED.all;

    entity top is -- top-level design for testing
        port(clk, reset: in STD_LOGIC;
            writedata, dataadr: buffer STD_LOGIC_VECTOR(31 downto
0);
            memwrite: buffer STD_LOGIC);
    end;

    architecture test of top is
        component mips
            port(clk, reset: in STD_LOGIC;
                pc: out STD_LOGIC_VECTOR(31 downto 0);
                instr: in STD_LOGIC_VECTOR(31 downto 0);
                memwrite: out STD_LOGIC;
                aluresult: out STD_LOGIC_VECTOR(31 downto 0);
                writedata: out STD_LOGIC_VECTOR(31 downto 0);
                readdata: in STD_LOGIC_VECTOR(31 downto 0));
        end component;
        component imem
            port(a: in STD_LOGIC_VECTOR(5 downto 0);
                rd: out STD_LOGIC_VECTOR(31 downto 0));
        end component;
        component dmem
            port(clk, we: in STD_LOGIC;
                a, wd: in STD_LOGIC_VECTOR(31 downto 0);
                rd: out STD_LOGIC_VECTOR(31 downto 0));
        end component;
        signal pc, instr,
            readdata: STD_LOGIC_VECTOR(31 downto 0);
    begin
        -- instantiate processor and memories
        mips1: mips port map(clk, reset, pc, instr, memwrite, dataadr,
            writedata, readdata);
        imem1: imem port map(pc(7 downto 2), instr);
        dmem1: dmem port map(clk, memwrite, dataadr, writedata, re-
addata);
    end;
```



```
library IEEE;
use IEEE.STD_LOGIC_1164.all; use STD.TEXTIO.all;
use IEEE.NUMERIC_STD_UNSIGNED.all;

entity dmem is -- data memory
  port(clk, we:  in STD_LOGIC;
        a, wd:   in STD_LOGIC_VECTOR(31 downto 0);
        rd:     out STD_LOGIC_VECTOR(31 downto 0));
end;

architecture behave of dmem is
begin
  process is
    type ramtype is array (63 downto 0) of STD_LOGIC_VECTOR(31
downto 0);
    variable mem: ramtype;
  begin
    -- read or write memory
    loop
      if clk'event and clk = '1' then
        if (we = '1') then mem(to_integer(a(7 downto 2))) := wd;
          end if;
        end if;
        rd <= mem(to_integer(a(7 downto 2)));
        wait on clk, a;
      end loop;

    end process;
end;

library IEEE;
use IEEE.STD_LOGIC_1164.all; use STD.TEXTIO.all;
use IEEE.NUMERIC_STD_UNSIGNED.all;

entity imem is -- instruction memory
  port(a:  in  STD_LOGIC_VECTOR(5 downto 0);
        rd: out STD_LOGIC_VECTOR(31 downto 0));
end;

architecture behave of imem is
begin
  process is
    file mem_file: TEXT;
    variable L: line;
    variable ch: character;
    variable i, index, result: integer;
    type ramtype is array (63 downto 0) of STD_LOGIC_VECTOR(31
downto 0);
    variable mem: ramtype;
  begin
    -- initialize memory from file
    for i in 0 to 63 loop -- set all contents low
```

```

        mem(i) := (others => '0');
    end loop;
    index := 0;
    FILE_OPEN(mem_file, "C:/docs/DDCA2e/hdl/memfile.dat",
READ_MODE);
    while not endfile(mem_file) loop
        readline(mem_file, L);
        result := 0;
        for i in 1 to 8 loop
            read(L, ch);
            if '0' <= ch and ch <= '9' then
                result := character'pos(ch) - character'pos('0');
            elsif 'a' <= ch and ch <= 'f' then
                result := character'pos(ch) - character'pos('a')+10;
            else report "Format error on line " & integer'image(index)
                severity error;
            end if;
            mem(index)(35-i*4 downto 32-i*4) :=to_std_logic_vector(result,4);
        end loop;
        index := index + 1;
    end loop;

    -- read memory
    loop
        rd <= mem(to_integer(a));
        wait on a;
    end loop;
end process;
end;

library IEEE; use IEEE.STD_LOGIC_1164.all;

entity mips is -- single cycle MIPS processor
    port(clk, reset:          in  STD_LOGIC;
         pc:                  out STD_LOGIC_VECTOR(31 downto 0);
         instr:               in  STD_LOGIC_VECTOR(31 downto 0);
         memwrite:           out STD_LOGIC;
         alurestult:         out STD_LOGIC_VECTOR(31 downto 0);
         writedata:         out STD_LOGIC_VECTOR(31 downto 0);
         readdata:          in  STD_LOGIC_VECTOR(31 downto 0));
end;

architecture struct of mips is
    component controller
        port(op, funct:          in  STD_LOGIC_VECTOR(5 downto 0);
             zero:              in  STD_LOGIC;
             memtoreg, memwrite: out STD_LOGIC;
             pcsrc:             out STD_LOGIC;
             alusrc:            out STD_LOGIC_VECTOR(1 downto 0); -- LUI
             regdst, regwrite:  out STD_LOGIC;
             jump:              out STD_LOGIC;
    end component;
end architecture;

```

```

        alucontrol:          out STD_LOGIC_VECTOR(3 downto 0); -
- SLL
        ltez:                out STD_LOGIC);                -- BLEZ
    end component;
    component datapath
        port(clk, reset:      in  STD_LOGIC;
            memtoreg, psrc:   in  STD_LOGIC;
            alusrc, regdst:   in  STD_LOGIC;
            regwrite, jump:   in  STD_LOGIC;
            alucontrol:       in  STD_LOGIC_VECTOR(2 downto 0);
            zero:             out STD_LOGIC;
            pc:               buffer STD_LOGIC_VECTOR(31 downto 0);
            instr:            in  STD_LOGIC_VECTOR(31 downto 0);
            aluresult:        buffer STD_LOGIC_VECTOR(31 downto 0);
            writedata:        buffer STD_LOGIC_VECTOR(31 downto 0);
            readdata:         in  STD_LOGIC_VECTOR(31 downto 0));
    end component;
    signal memtoreg: STD_LOGIC;
    signal alusrc: STD_LOGIC_VECTOR(1 downto 0); -- LUI
    signal regdst, regwrite, jump, psrc: STD_LOGIC;
    signal zero: STD_LOGIC;
    signal alucontrol: STD_LOGIC_VECTOR(3 downto 0); -- SLL
    signal ltez: STD_LOGIC; -- BLEZ
begin
    cont: controller port map(instr(31 downto 26), instr(5 downto
0),
                                zero, memtoreg, memwrite, psrc, alusrc,
                                regdst, regwrite, jump, alucontrol,
                                ltez); -- BLEZ
    dp: datapath port map(clk, reset, memtoreg, psrc, alusrc,
regdst,
                                regwrite, jump, alucontrol, zero, pc, instr,
                                aluresult, writedata, readdata,
                                ltez); -- BLEZ
end;

library IEEE; use IEEE.STD_LOGIC_1164.all;

entity controller is -- single cycle control decoder
    port(op, funct:         in  STD_LOGIC_VECTOR(5 downto 0);
        zero:              in  STD_LOGIC;
        memtoreg, memwrite: out STD_LOGIC;
        psrc:              out STD_LOGIC;
        alusrc:            out STD_LOGIC_VECTOR(1 downto 0); -- LUI
        regdst, regwrite:   out STD_LOGIC;
        jump:              out STD_LOGIC;
        alucontrol:        out STD_LOGIC_VECTOR(3 downto 0); -
- SLL
        ltez:              out STD_LOGIC);                -- BLEZ
    end;

architecture struct of controller is
    component maindec

```

```

        port(op:                in  STD_LOGIC_VECTOR(5 downto 0);
              memtoreg, memwrite: out STD_LOGIC;
              branch:           out  STD_LOGIC;
              alusrc:           out  STD_LOGIC_VECTOR(1 downto 0);
-- LUI
              regdst, regwrite: out  STD_LOGIC;
              jump:             out  STD_LOGIC;
              aluop:            out  STD_LOGIC_VECTOR(1 downto 0);
              blez:             out  STD_LOGIC);
    end component;
    component aludec
        port(funcnt:           in  STD_LOGIC_VECTOR(5 downto 0);
              aluop:           in  STD_LOGIC_VECTOR(1 downto 0);
              alucontrol:      out STD_LOGIC_VECTOR(3 downto 0)); -- SLL
    end component;
    signal aluop: STD_LOGIC_VECTOR(1 downto 0);
    signal branch: STD_LOGIC;
    signal blez:   STD_LOGIC; --BLEZ
begin
    md: maindec port map(op, memtoreg, memwrite, branch,
                        alusrc, regdst, regwrite, jump, aluop, blez);
    ad: aludec port map(funcnt, aluop, alucontrol);

--BLEZ
    pcsrc <= (branch and zero) or (blez and ltez);
end;

library IEEE; use IEEE.STD_LOGIC_1164.all;

entity maindec is -- main control decoder
    port(op:                in  STD_LOGIC_VECTOR(5 downto 0);
          memtoreg, memwrite: out STD_LOGIC;
          branch:           out  STD_LOGIC;
          alusrc:           out  STD_LOGIC_VECTOR(1 downto 0); -- LUI
          regdst, regwrite: out  STD_LOGIC;
          jump:             out  STD_LOGIC;
          aluop:            out  STD_LOGIC_VECTOR(1 downto 0);
          blez:             out  STD_LOGIC);
end;

architecture behave of maindec is
    signal controls: STD_LOGIC_VECTOR(10 downto 0);
begin
    process(all) begin
        case op is
            when "000000" => controls <= "11000001000"; -- RTYPE
            when "100011" => controls <= "10010010000"; -- LW
            when "101011" => controls <= "00010100000"; -- SW
            when "000100" => controls <= "00001000100"; -- BEQ
            when "001000" => controls <= "10010000000"; -- ADDI
            when "000010" => controls <= "00000000010"; -- J
            when "001010" => controls <= "10010001100"; -- SLTI
            when "001111" => controls <= "10100000000"; -- LUI
        end case;
    end process;
end behave;

```

```

        when "000110" => controls <= "00000000101"; -- BLEZ
        when others    => controls <= "-----"; -- illegal op
    end case;
end process;

    (regwrite, regdst, alusrc, branch, memwrite,
     memtoreg, aluop(1 downto 0), jump, blez) <= controls;
end;

library IEEE; use IEEE.STD_LOGIC_1164.all;

entity aludec is -- ALU control decoder
    port(funcnt:      in  STD_LOGIC_VECTOR(5 downto 0);
          aluop:      in  STD_LOGIC_VECTOR(1 downto 0);
          alucontrol: out STD_LOGIC_VECTOR(3 downto 0)); -- SLL
end;

architecture behave of aludec is
begin
    process(all) begin
        case aluop is
            when "00" => alucontrol <= "0010"; -- add
            when "01" => alucontrol <= "1010"; -- sub
            when "11" => alucontrol <= "1011"; -- slt
            when others => case funcnt is -- R-type instructions
                when "100000" => alucontrol <= "0010";
                when "100010" => alucontrol <= "1010";
                when "100100" => alucontrol <= "0000";
                when "100101" => alucontrol <= "0001"; -- or
                when "101010" => alucontrol <= "1011";
                when "000000" => alucontrol <= "0100";
                when others => alucontrol <= "----"; -- ???
            end case;
        end case;
    end process;
end;

library IEEE; use IEEE.STD_LOGIC_1164.all; use IEEE.STD_LOG-
IC_ARITH.all;

entity datapath is -- MIPS datapath
    port(clk, reset:      in  STD_LOGIC;
          memtoreg, pcsrc: in  STD_LOGIC;
          alusrc:         in  STD_LOGIC_VECTOR(1 downto 0); -- LUI
          alusrc, regdst: in  STD_LOGIC;
          regwrite, jump: in  STD_LOGIC;
          alucontrol:     in  STD_LOGIC_VECTOR(3 downto 0); --
- SLL

```

```

        zero:          out STD_LOGIC;
    pc:              buffer STD_LOGIC_VECTOR(31 downto 0);
    instr:          in STD_LOGIC_VECTOR(31 downto 0);
    aluresult:      buffer STD_LOGIC_VECTOR(31 downto 0);
    writedata:      buffer STD_LOGIC_VECTOR(31 downto 0);
    readdata:       in STD_LOGIC_VECTOR(31 downto 0);
    ltez:           out STD_LOGIC);          -- LTEZ
end;

architecture struct of datapath is
    component alu
        port(a, b:          in STD_LOGIC_VECTOR(31 downto 0);
            alucontrol: in STD_LOGIC_VECTOR(3 downto 0);    --SLL
            shamt:        in STD_LOGIC_VECTOR(4 downto 0);  --SLL
            result:       buffer STD_LOGIC_VECTOR(31 downto 0);
            zero:         buffer STD_LOGIC;                  --BLEZ
            ltez:         out STD_LOGIC);                    --BLEZ
    end component;
    component regfile
        port(clk:          in STD_LOGIC;
            we3:           in STD_LOGIC;
            ra1, ra2, wa3: in STD_LOGIC_VECTOR(4 downto 0);
            wd3:           in STD_LOGIC_VECTOR(31 downto 0);
            rd1, rd2:      out STD_LOGIC_VECTOR(31 downto 0));
    end component;
    component adder
        port(a, b: in STD_LOGIC_VECTOR(31 downto 0);
            y: out STD_LOGIC_VECTOR(31 downto 0));
    end component;
    component sl2
        port(a: in STD_LOGIC_VECTOR(31 downto 0);
            y: out STD_LOGIC_VECTOR(31 downto 0));
    end component;
    component signext
        port(a: in STD_LOGIC_VECTOR(15 downto 0);
            y: out STD_LOGIC_VECTOR(31 downto 0));
    end component;
    component upimm
        port(a: in STD_LOGIC_VECTOR(15 downto 0);
            y: out STD_LOGIC_VECTOR(31 downto 0));
    end component;
    component flopr generic(width: integer);
        port(clk, reset: in STD_LOGIC;
            d:          in STD_LOGIC_VECTOR(width-1 downto 0);
            q:          out STD_LOGIC_VECTOR(width-1 downto 0));
    end component;
    component mux2 generic(width: integer);
        port(d0, d1: in STD_LOGIC_VECTOR(width-1 downto 0);
            s:      in STD_LOGIC;
            y:      out STD_LOGIC_VECTOR(width-1 downto 0));
    end component;
    component mux3 generic(width: integer);
        port(d0, d1, d2: in STD_LOGIC_VECTOR(width-1 downto 0);

```

```
        s:          in  STD_LOGIC_VECTOR(1 downto 0);
        y:          out STD_LOGIC_VECTOR(width-1 downto 0));
end component;
signal writereg:   STD_LOGIC_VECTOR(4 downto 0);
signal pcjump, pcnext,
       pcnextbr, pcplus4,
       pcbranch:   STD_LOGIC_VECTOR(31 downto 0);
signal upperimm:   STD_LOGIC_VECTOR(31 downto 0); --
- LUI
  signal signimm, signimmsh: STD_LOGIC_VECTOR(31 downto 0);
  signal srca, srcb, result: STD_LOGIC_VECTOR(31 downto 0);
begin
  -- next PC logic
  pcjump <= pcplus4(31 downto 28) & instr(25 downto 0) & "00";
  pcreg: flopr generic map(32) port map(clk, reset, pcnext, pc);
  pcadd1: adder port map(pc, X"00000004", pcplus4);
  immsh: sl2 port map(signimm, signimmsh);
  pcadd2: adder port map(pcplus4, signimmsh, pcbranch);
  pcbrmux: mux2 generic map(32) port map(pcplus4, pcbranch,
                                         pcsrc, pcnextbr);
  pcmux: mux2 generic map(32) port map(pcnextbr, pcjump, jump,
                                       pcnext);

  -- register file logic
  rf: regfile port map(clk, regwrite, instr(25 downto 21),
                      instr(20 downto 16), writereg, result, srca,
                      writedata);
  wrmux: mux2 generic map(5) port map(instr(20 downto 16),
                                      instr(15 downto 11),
                                      regdst, writereg);
  resmux: mux2 generic map(32) port map(alurest, readdata,
                                       memtoreg, result);
  se: signext port map(instr(15 downto 0), signimm);
  ui: upimm port map(instr(15 downto 0), upperimm); --LUI

  -- ALU logic
  srcbmux: mux3 generic map(32) port map(writedata, signimm,
                                       upperimm,
                                       alusrc, srcb); -- LUI
  mainalu: alu port map(srca, srcb, alucontrol, instr(10 downto
6), --SLL
                      alurest, zero, ltez); --BLEZ

end;

library IEEE; use IEEE.STD_LOGIC_1164.all;
use IEEE.NUMERIC_STD_UNSIGNED.all;

entity regfile is -- three-port register file
  port(clk:          in  STD_LOGIC;
       we3:         in  STD_LOGIC;
       ra1, ra2, wa3: in  STD_LOGIC_VECTOR(4 downto 0);
       wd3:         in  STD_LOGIC_VECTOR(31 downto 0);
```

```
        rd1, rd2:      out STD_LOGIC_VECTOR(31 downto 0));
    end;

    architecture behave of regfile is
        type ramtype is array (31 downto 0) of STD_LOGIC_VECTOR(31
downto 0);
        signal mem: ramtype;
    begin
        -- three-ported register file
        -- read two ports combinationally
        -- write third port on rising edge of clock
        -- register 0 hardwired to 0
        process(clk) begin
            if rising_edge(clk) then
                if we3 = '1' then mem(to_integer(wa3)) <= wd3;
                    end if;
            end if;
        end process;
        process(all) begin
            if (to_integer(ral) = 0) then rd1 <= X"00000000"; -- register
0 holds 0
                else rd1 <= mem(to_integer(ral));
                    end if;
            if (to_integer(ra2) = 0) then rd2 <= X"00000000";
                else rd2 <= mem(to_integer(ra2));
                    end if;
        end process;
    end;

    library IEEE; use IEEE.STD_LOGIC_1164.all;
    use IEEE.NUMERIC_STD_UNSIGNED.all;

    entity adder is -- adder
        port(a, b: in  STD_LOGIC_VECTOR(31 downto 0);
            y:      out STD_LOGIC_VECTOR(31 downto 0));
    end;

    architecture behave of adder is
    begin
        y <= a + b;
    end;

    library IEEE; use IEEE.STD_LOGIC_1164.all;

    entity sl2 is -- shift left by 2
        port(a: in  STD_LOGIC_VECTOR(31 downto 0);
            y: out STD_LOGIC_VECTOR(31 downto 0));
    end;

    architecture behave of sl2 is
    begin
        y <= a(29 downto 0) & "00";
```



```
end;

library IEEE; use IEEE.STD_LOGIC_1164.all;

entity signext is -- sign extender
  port(a: in  STD_LOGIC_VECTOR(15 downto 0);
        y: out STD_LOGIC_VECTOR(31 downto 0));
end;

architecture behave of signext is
begin
  y <= X"ffff" & a when a(15) else X"0000" & a;
end;

library IEEE; use IEEE.STD_LOGIC_1164.all;
entity upimm is -- create upper immediate for LUI
  port(a: in  STD_LOGIC_VECTOR(15 downto 0);
        y: out STD_LOGIC_VECTOR(31 downto 0));
end;

architecture behave of upimm is
begin
  y <= a & X"0000";
end;

library IEEE; use IEEE.STD_LOGIC_1164.all; use IEEE.STD_LOGIC_
IC_ARITH.all;

entity flopr is -- flip-flop with synchronous reset
  generic(width: integer);
  port(clk, reset: in  STD_LOGIC;
        d:          in  STD_LOGIC_VECTOR(width-1 downto 0);
        q:          out STD_LOGIC_VECTOR(width-1 downto 0));
end;

architecture asynchronous of flopr is
begin
  process(clk, reset) begin
    if reset then q <= (others => '0');
    elsif rising_edge(clk) then
      q <= d;
    end if;
  end process;
end;

library IEEE; use IEEE.STD_LOGIC_1164.all;
entity mux2 is -- two-input multiplexer
  generic(width: integer);
  port(d0, d1: in  STD_LOGIC_VECTOR(width-1 downto 0);
        s:     in  STD_LOGIC;
        y:     out STD_LOGIC_VECTOR(width-1 downto 0));
end;
```

```
architecture behave of mux2 is
begin
    y <= d1 when s else d0;
end;

-- 3:1 mux needed for LUI
library IEEE; use IEEE.STD_LOGIC_1164.all;
entity mux3 is -- three-input multiplexer
    generic(width: integer);
    port(d0, d1, d2: in STD_LOGIC_VECTOR(width-1 downto 0);
          s:         in STD_LOGIC_VECTOR(1 downto 0);
          y:         out STD_LOGIC_VECTOR(width-1 downto 0));
end;

architecture behave of mux3 is
begin
    y <= d1 when s(1) else (d1 when s(0) else d0);
end;

library IEEE; use IEEE.STD_LOGIC_1164.all;
use IEEE.NUMERIC_STD_UNSIGNED.all;

entity alu is
    port(a, b:         in STD_LOGIC_VECTOR(31 downto 0);
          alucontrol: in STD_LOGIC_VECTOR(3 downto 0); --SLL
          shamt:       in STD_LOGIC_VECTOR(4 downto 0); --SLL
          result:      buffer STD_LOGIC_VECTOR(31 downto 0);
          zero:        buffer STD_LOGIC; --BLEZ
          ltez:        out STD_LOGIC); --BLEZ
end;

architecture behave of alu is
    signal condinvb, sum: STD_LOGIC_VECTOR(31 downto 0);
begin
    condinvb <= not b when alucontrol(3) else b;
    sum <= a + condinvb + alucontrol(3);

    process(all) begin
        case alucontrol(2 downto 0) is
            when "000" => result <= a and b;
            when "001" => result <= a or b;
            when "010" => result <= sum;
            when "011" => result <= (0 => sum(31), others => '0');
            when "100" => result <= (condinvb << shamt); --SLL
            when others => result <= (others => 'X');
        end case;
    end process;

    zero <= '1' when result = X"00000000" else '0';
    ltez <= zero or sum(31);
end;
```

Exercise 7.13

(a) srlv

First, we show the modifications to the ALU.

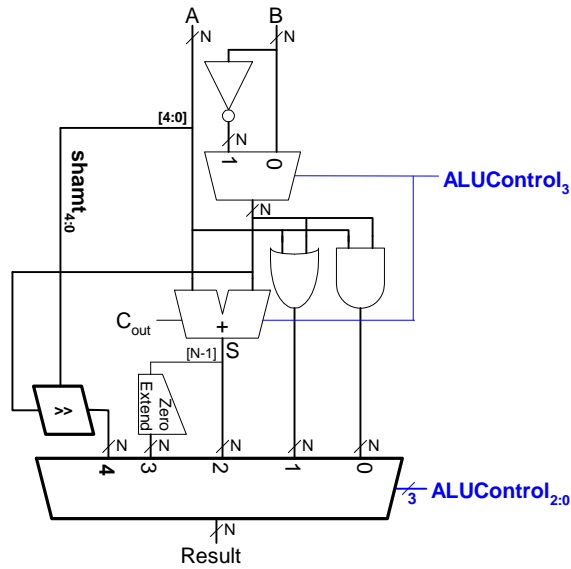

FIGURE 7.5 Modified ALU to support srlv

Next, we show the modifications to the ALU decoder.

ALUControl _{3:0}	Function
0000	A AND B
0001	A OR B
0010	A + B
0011	not used
1000	A AND \bar{B}
1001	A OR \bar{B}
1010	A - B
1011	SLT
0100	SRLV

FIGURE 7.6 Modified ALU operations to support SRLV

ALUOp	Funct	ALUControl
00	X	0010 (add)
X1	X	1010 (subtract)
1X	100000 (add)	0010 (add)
1X	100010 (sub)	1010 (subtract)
1X	100100 (and)	0000 (and)
1X	100101 (or)	0001 (or)
1X	101010 (slt)	1011 (set less than)
1X	000110 (srlv)	0100 (shift right logical variable)

TABLE 7.8 ALU decoder truth table

Next, we show the changes to the datapath. The only modification is the width of *ALUControl*. No changes are made to the datapath main control FSM.

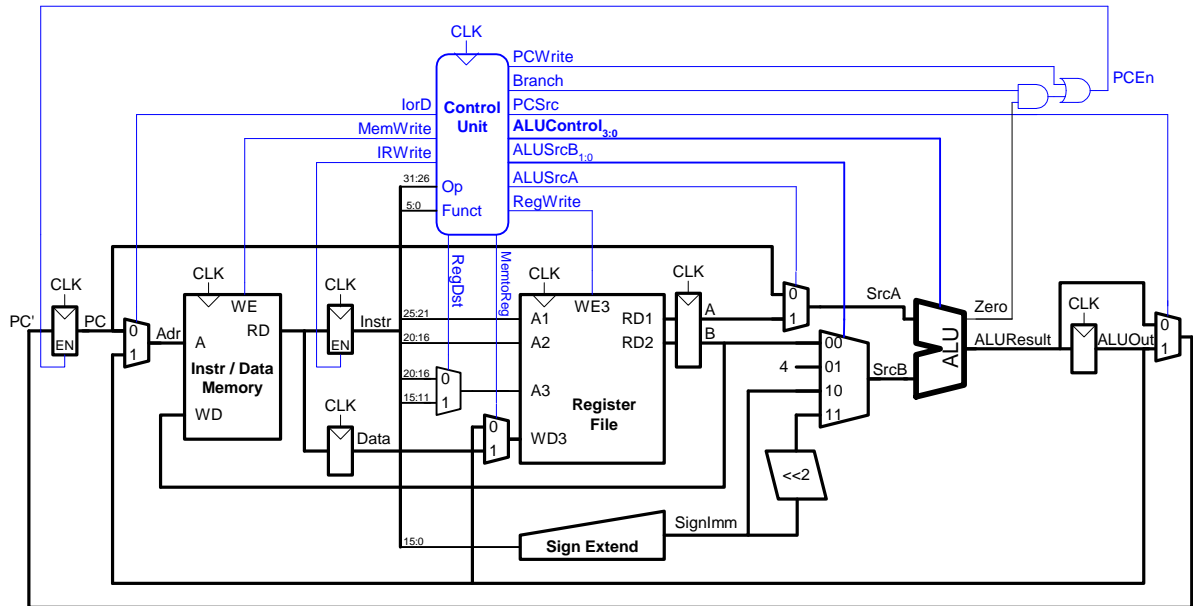

FIGURE 7.7 Modified multicycle MIPS datapath to support `sll`

(b) `ori`

We add a zero extension unit to the datapath, extend the *ALUSrcB* signal from 2 bits to 3 bits, and extend the SrcB multiplexer from 4 inputs to 5 inputs. We also modify the ALU decoder and main control FSM.

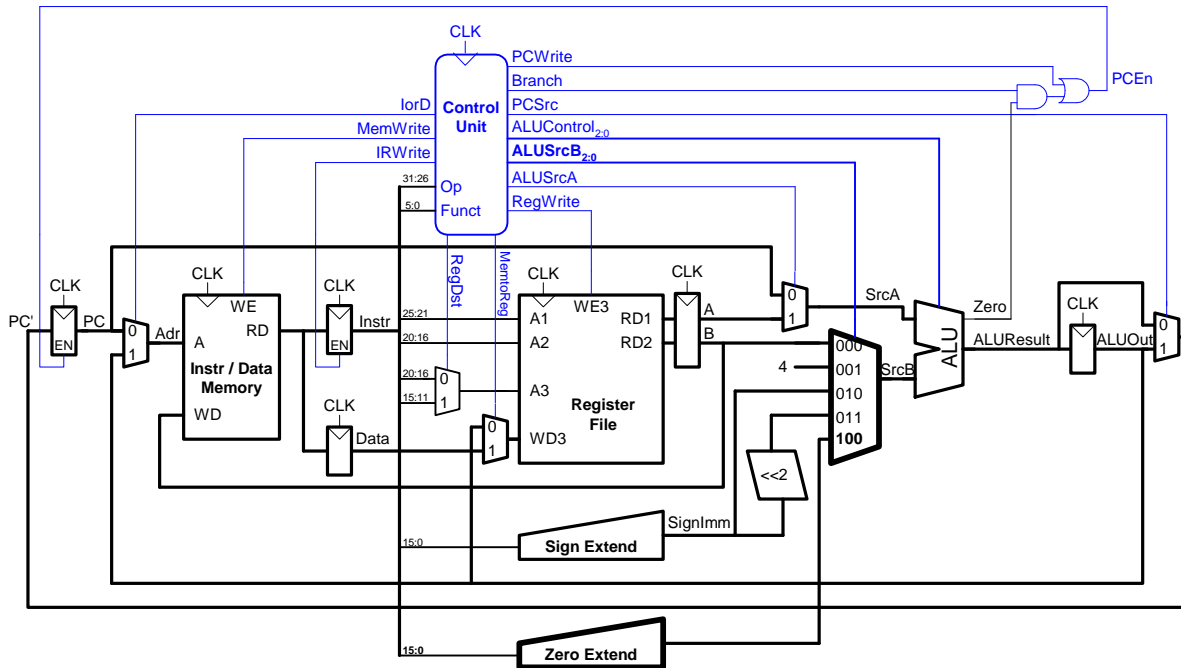

FIGURE 7.8 Modified datapath for *ori*

ALUOp	Func	ALUControl
00	X	010 (add)
01	X	110 (subtract)
11	X	001 (or)
10	100000 (add)	010 (add)
10	100010 (sub)	110 (subtract)
10	100100 (and)	000 (and)

TABLE 7.9 ALU decoder truth table

ALUOp	Funct	ALUControl
10	100101 (or)	001 (or)
10	101010 (slt)	111 (set less than)

TABLE 7.9 ALU decoder truth table

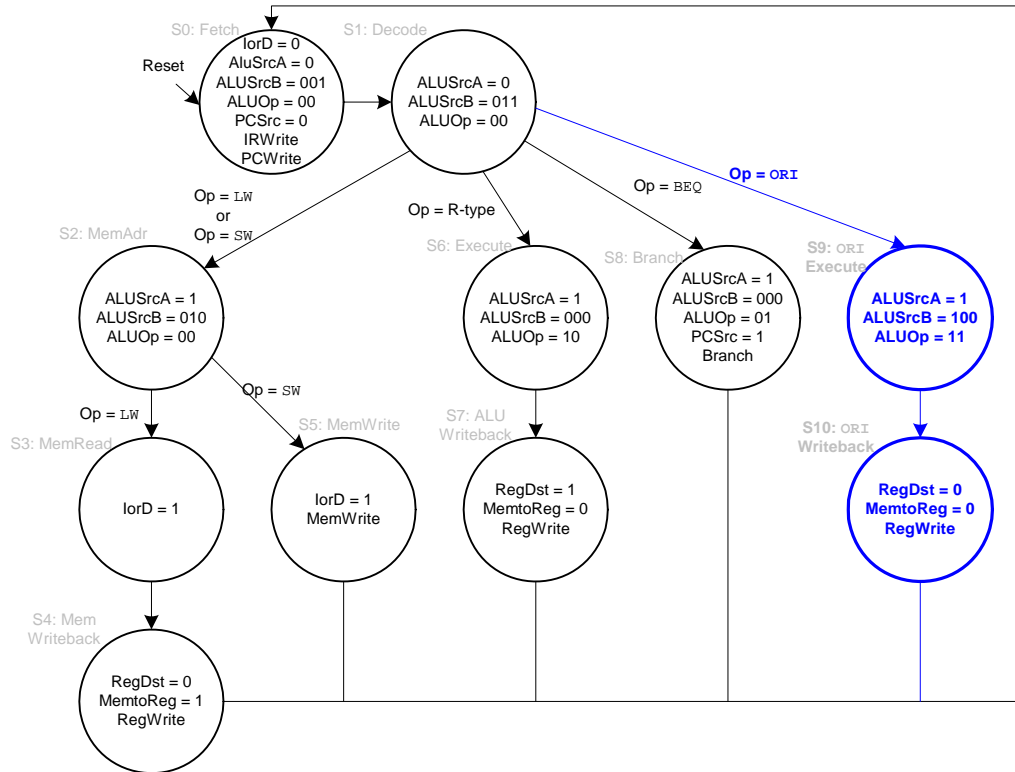

(c) xori

First, we modify the ALU and the ALU decoder.

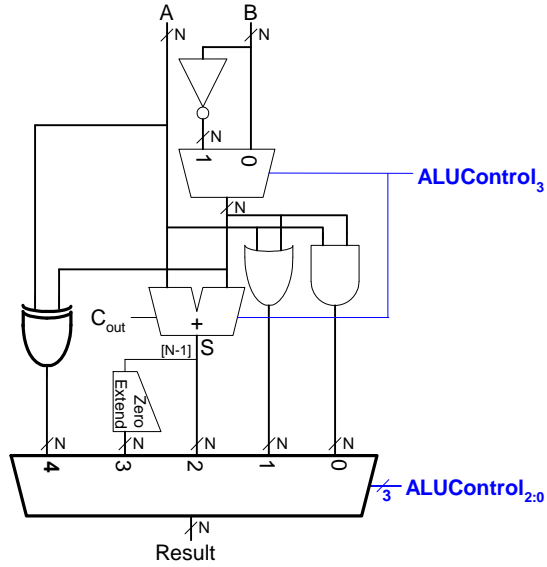

1

ALUControl _{3:0}	Function
0000	A AND B
0001	A OR B
0010	A + B
0011	not used
1000	A AND \overline{B}
1001	A OR \overline{B}
1010	A - B
1011	SLT
0100	A XOR B

ALUOp	Funct	ALUControl
00	X	0010 (add)
01	X	1010 (subtract)
11	X	0100 (xor)
10	100000 (add)	0010 (add)
10	100010 (sub)	1010 (subtract)
10	100100 (and)	0000 (and)
10	100101 (or)	0001 (or)
10	101010 (slt)	1011 (set less than)

TABLE 7.10 ALU decoder truth table for `xori`

Next, we modify the datapath. We change the buswidth of the *ALUControl* signal from 3 bits to 4 bits and the *ALUSrcB* signal from 2 bits to 3 bits. We also extend the SrcB mux and add a zero-extension unit.

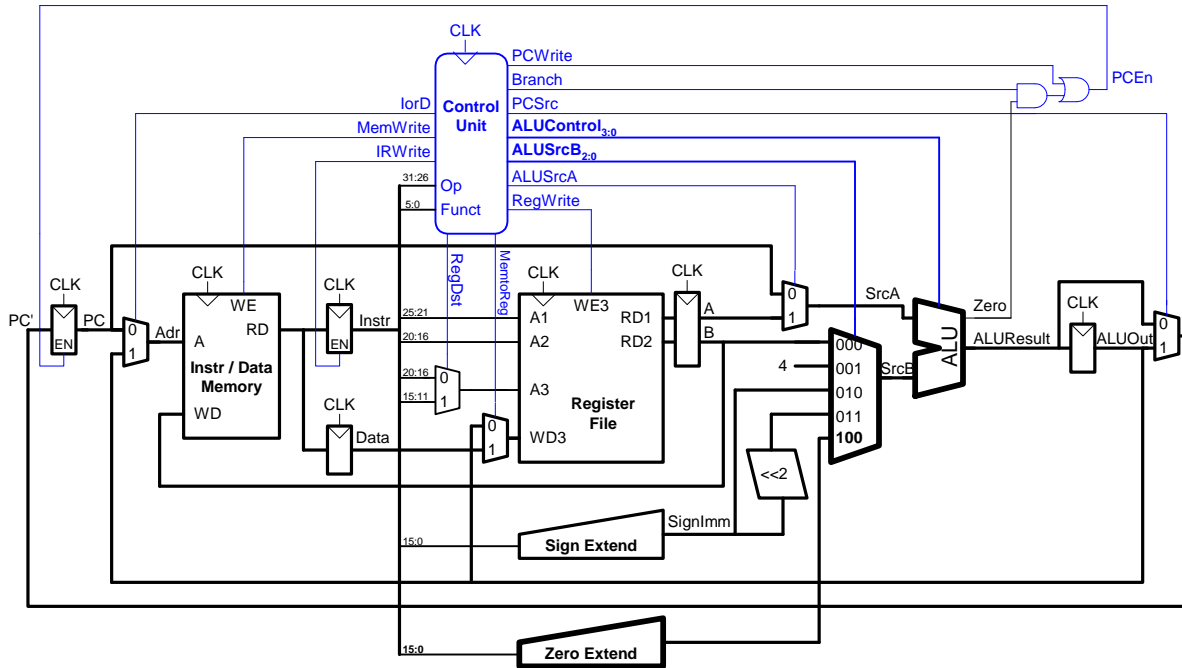

And finally, we modify the main control FSM.

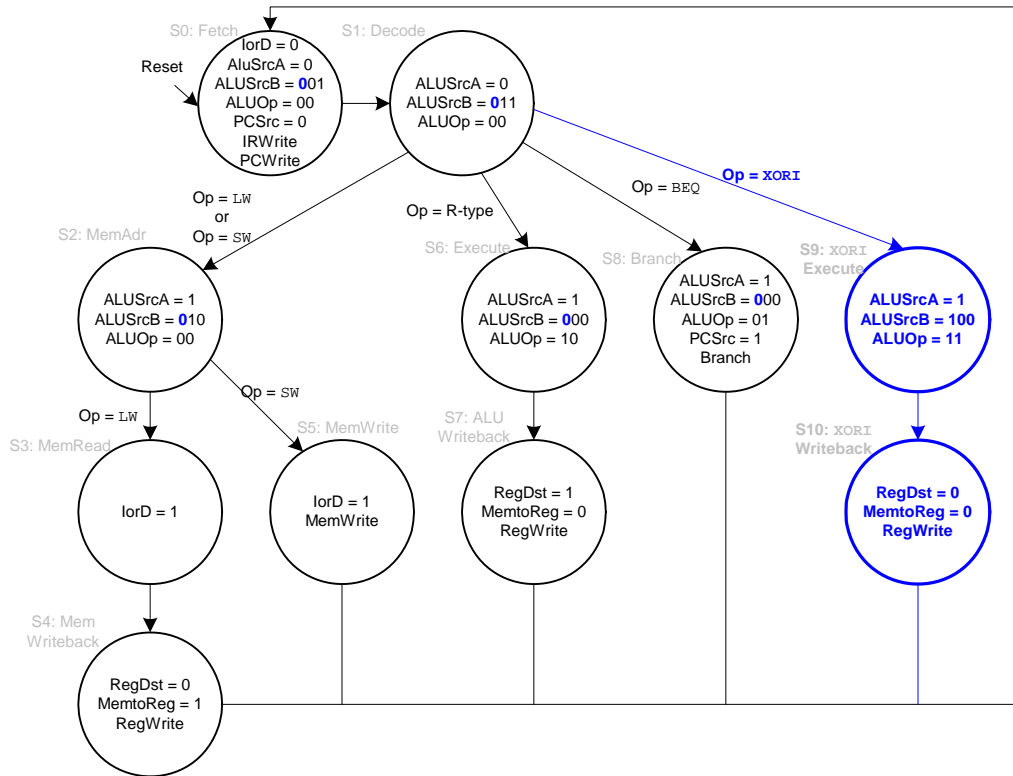

(d) jr

First, we extend the ALU Decoder for jr.

ALUOp	Funct	ALUControl
00	X	010 (add)
X1	X	110 (subtract)
1X	10000 (add)	010 (add)
1X	100010 (sub)	110 (subtract)
1X	100100 (and)	000 (and)
1X	100101 (or)	001 (or)

TABLE 7.11 ALU decoder truth table with jr

ALUOp	Funct	ALUControl
1X	101010 (slt)	111 (set less than)
1X	001000 (jr)	010 (add)

TABLE 7.11 ALU decoder truth table with jr

Next, we modify the main controller. The datapath requires no modification.

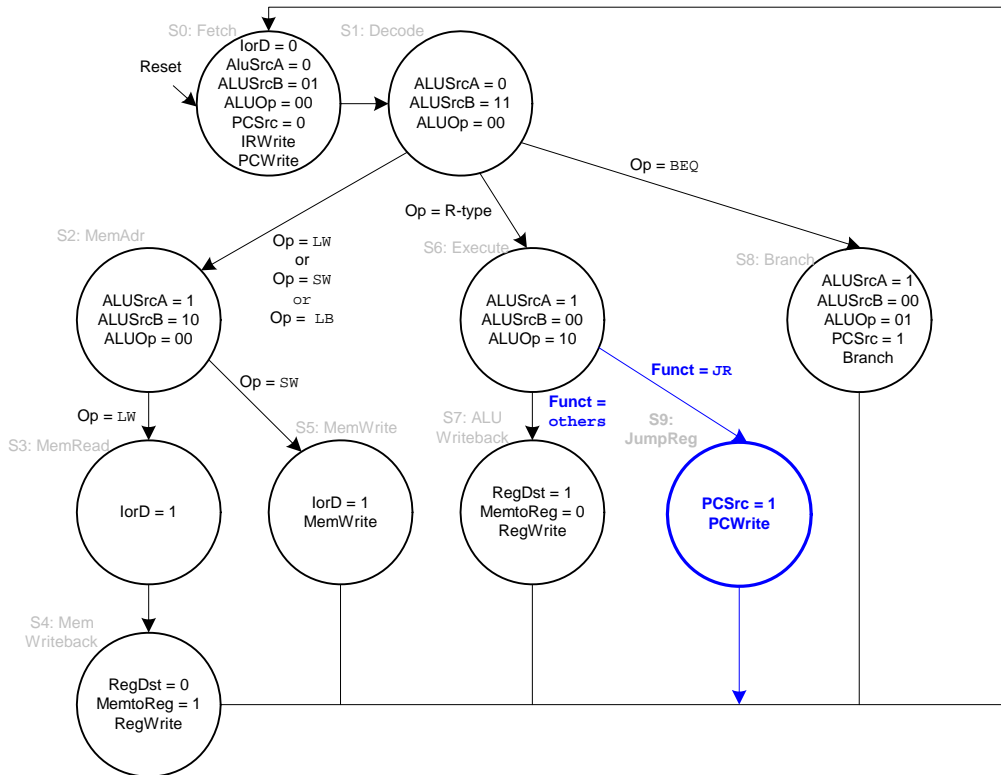

Exercise 7.15

Yes, it is possible to add this instruction without modifying the register file. First we show the modifications to the datapath. The only modification is adding the rs field of the instruction ($Instruction_{25:21}$) to the input of the write address mux of the register file. $RegDst$ must be expanded to two bits.

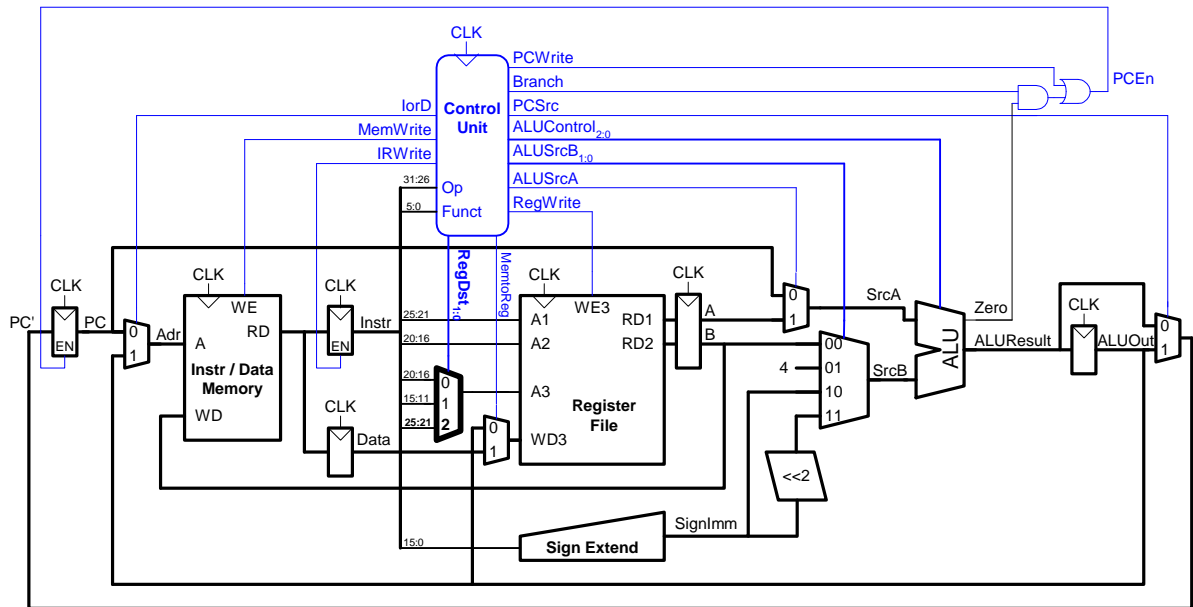

The finite state machine requires another state to write the *rs* register. If execution time is critical, another adder could be placed just after the A/B register to add 4 to A. Then in State 3, as memory is read, the register file could be written back with the incremented *rs*. In that case, *lwinc* would require the same number of cycles as *lw*. The penalty, however, would be chip area, and thus power and cost.

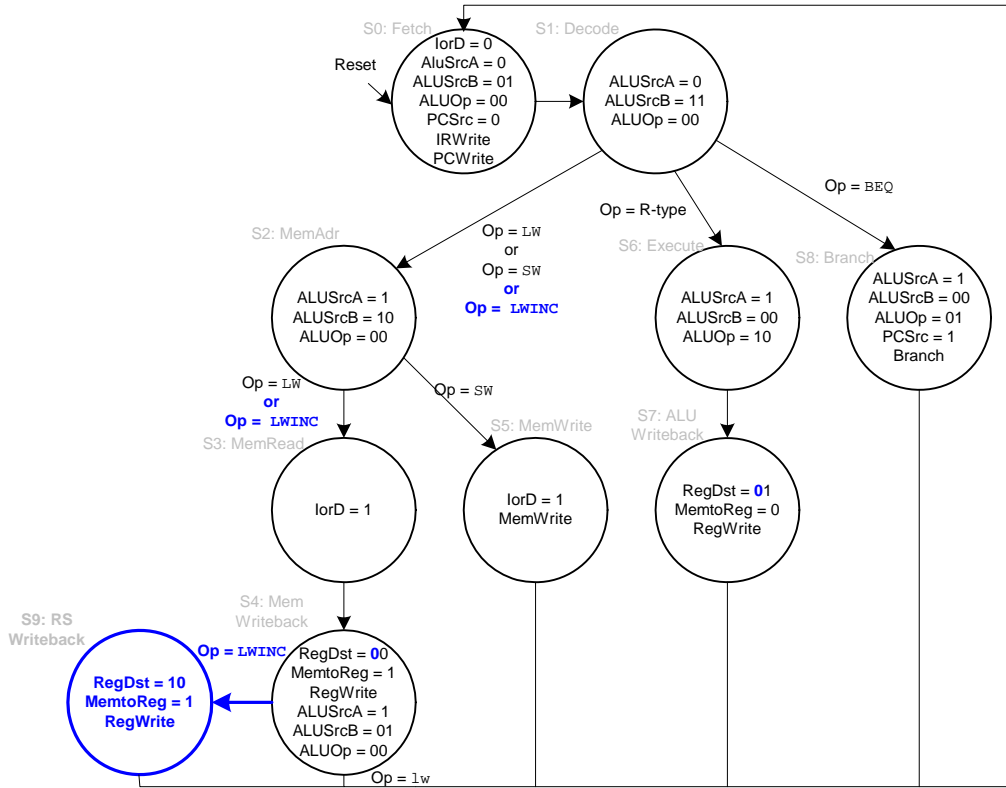

Exercise 7.17

We add an enable signal, *FIPtEn*, to the result register.

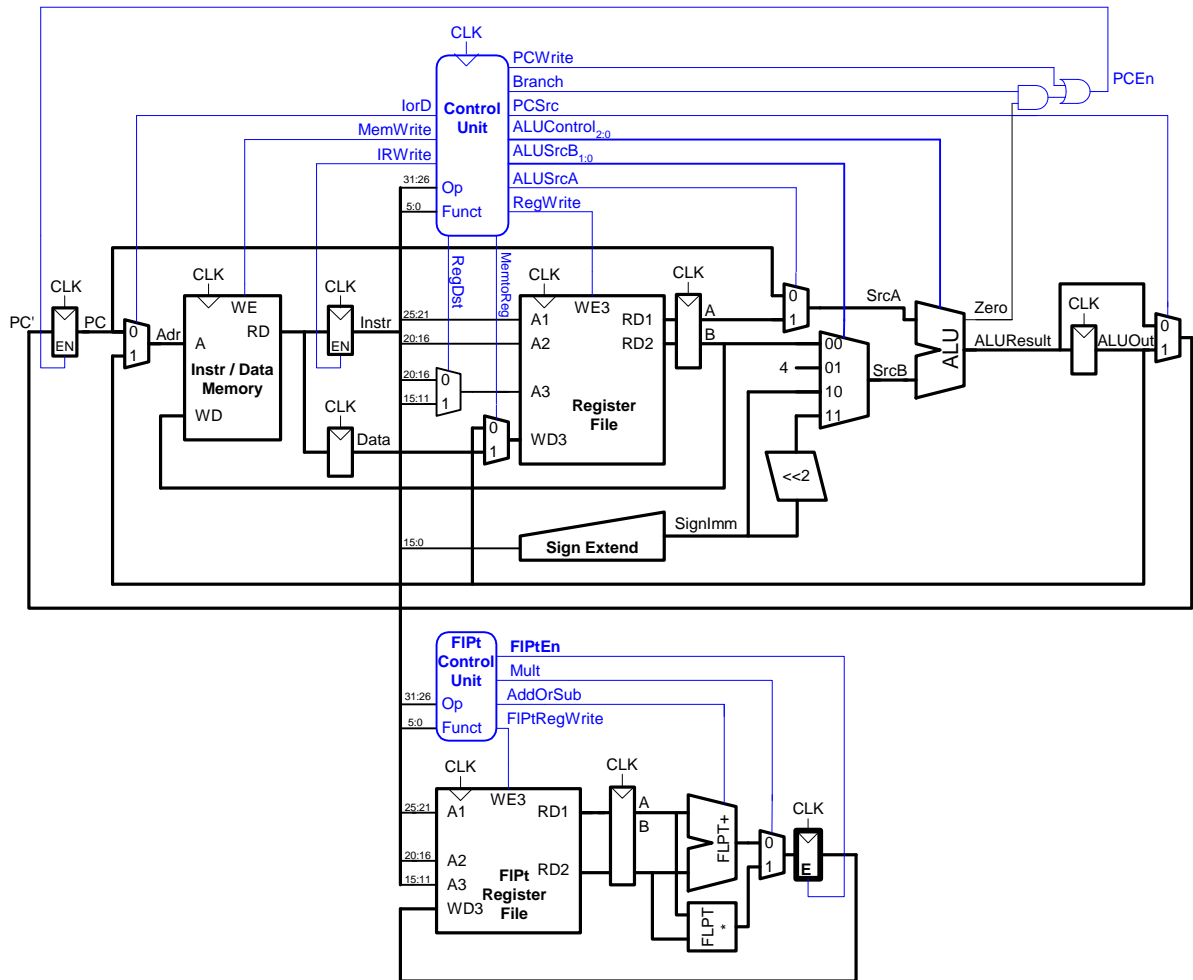

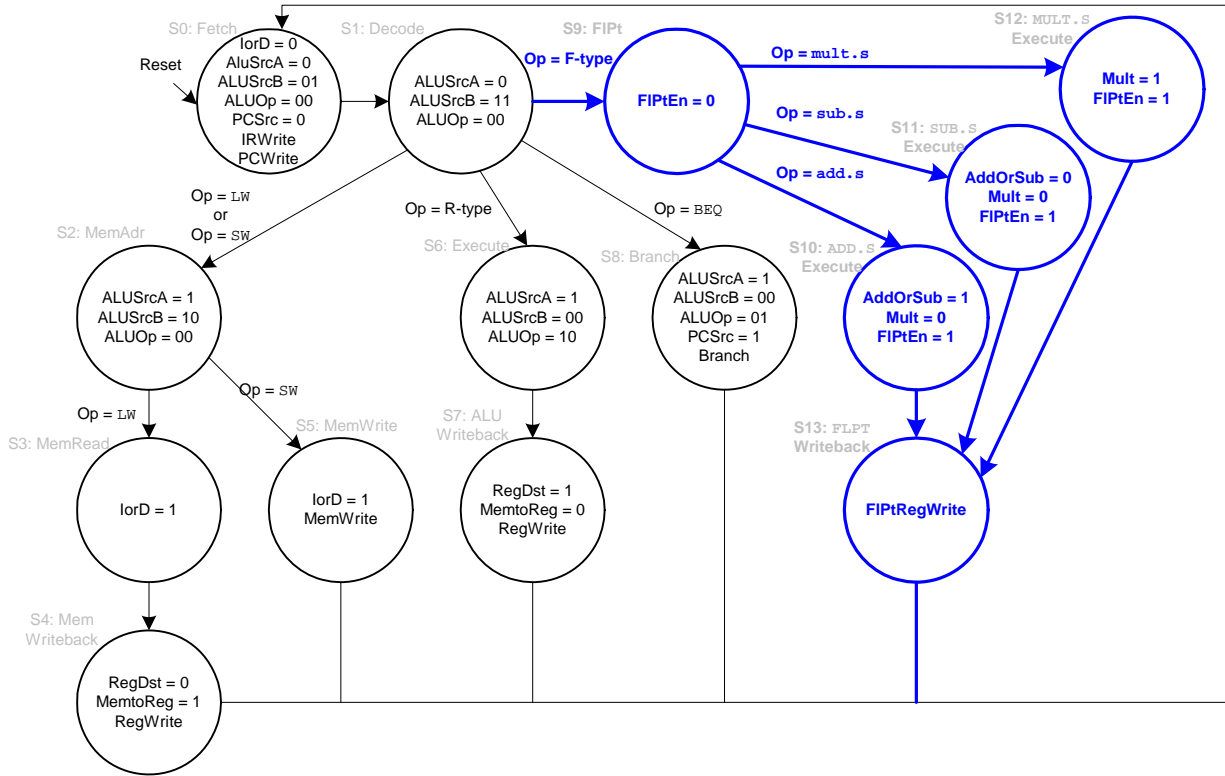

Exercise 7.19

Because the ALU is not on the critical path, the speedup in performance of the ALU does not affect the cycle time. Thus, the cycle time, given in Example 7.8, is still 325 ps. Given the instruction mix in Example 7.7, the overall execution time for 100 billion instructions is still 133.9 seconds.

Exercise 7.21

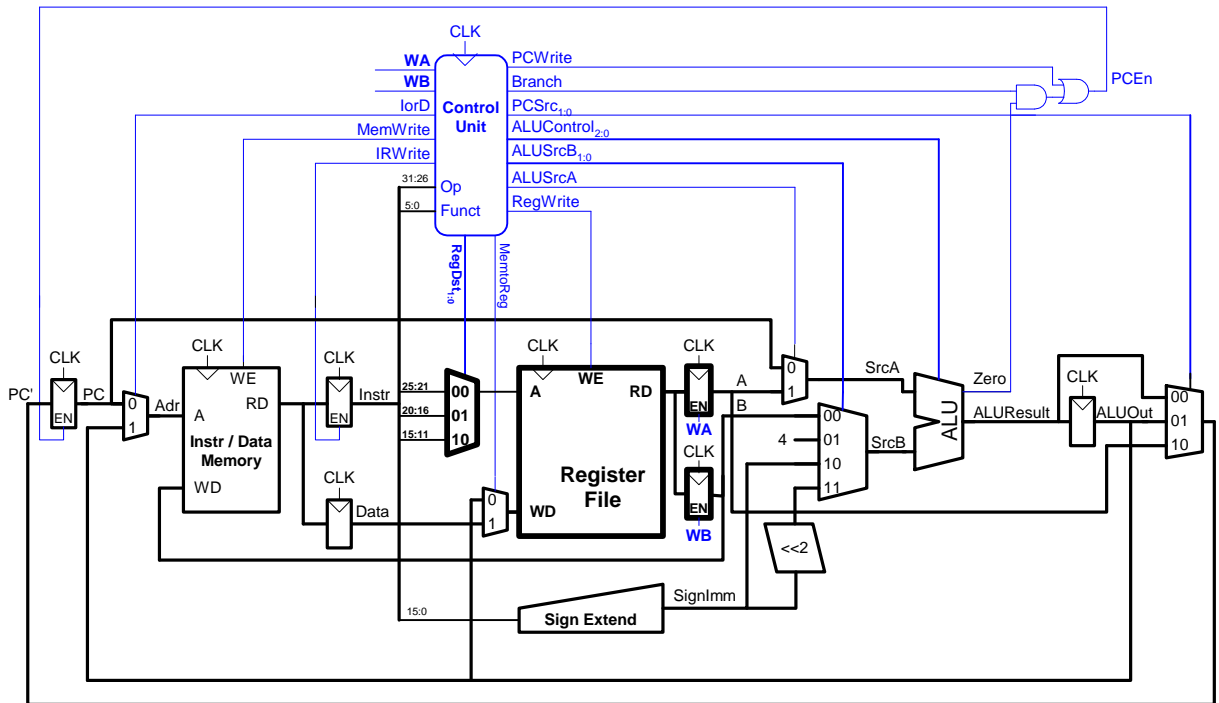

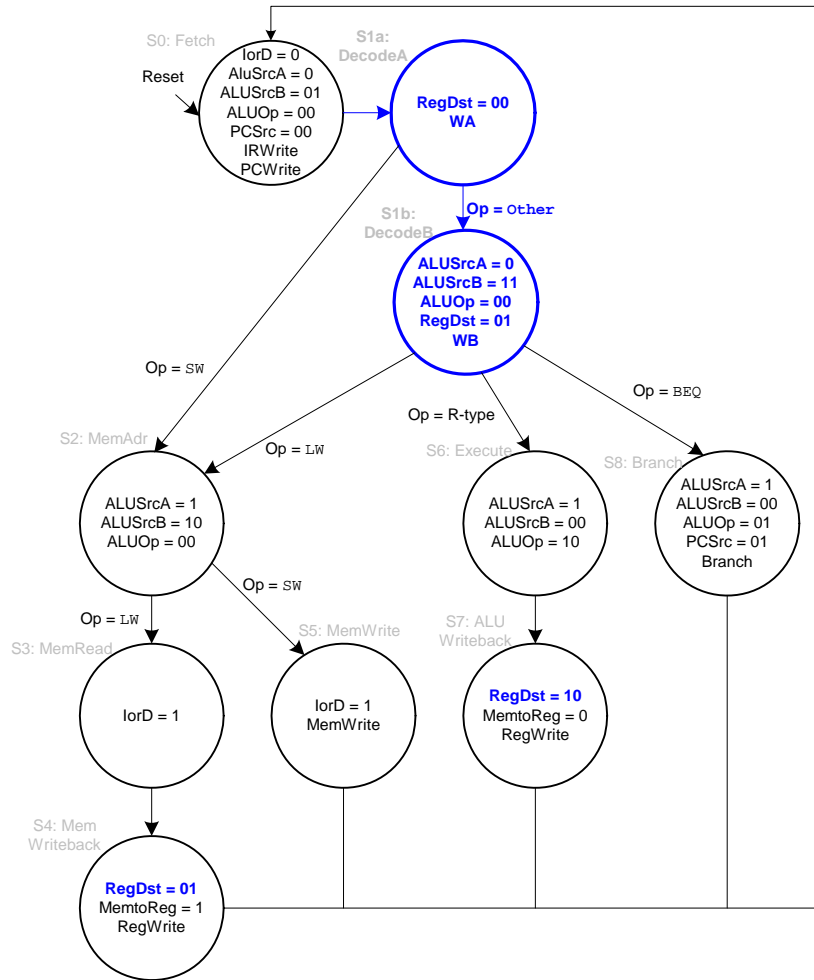

Exercise 7.23

$$4 + (3 + 4 + 3) \times 5 + 3 = \mathbf{57 \text{ clock cycles}}$$

The number of instructions executed is $1 + (3 \times 5) + 1 = 17$. Thus, the CPI = 57 clock cycles / 17 instructions = **3.35 CPI**

Exercise 7.25**MIPS Multicycle Processor****SystemVerilog**

```

module mips(input  logic      clk, reset,
            output logic [31:0] adr, writedata,
            output logic      memwrite,
            input  logic [31:0] readdata);

    logic      zero, pcen, irwrite, regwrite,
               alusrca, iord, memtoreg, regdst;
    logic [1:0] alusrcb, pcsrc;
    logic [2:0] alucontrol;
    logic [5:0] op, funct;

    controller c(clk, reset, op, funct, zero,
                pcen, memwrite, irwrite, regwrite,
                alusrca, iord, memtoreg, regdst,
                alusrcb, pcsrc, alucontrol);
    datapath dp(clk, reset,
                pcen, irwrite, regwrite,
                alusrca, iord, memtoreg, regdst,
                alusrcb, pcsrc, alucontrol,
                op, funct, zero,
                adr, writedata, readdata);
endmodule

```

VHDL

```

library IEEE; use IEEE.STD_LOGIC_1164.all;

entity mips is -- multicycle MIPS processor
    port(clk, reset:      in  STD_LOGIC;
          adr:            out STD_LOGIC_VECTOR(31 downto 0);
          writedata:     inout STD_LOGIC_VECTOR(31 downto 0);
          memwrite:      out  STD_LOGIC;
          readdata:      in  STD_LOGIC_VECTOR(31 downto 0));
end;

architecture struct of mips is
    component controller
        port(clk, reset:      in  STD_LOGIC;
              op, funct:     in  STD_LOGIC_VECTOR(5 downto 0);
              zero:         in  STD_LOGIC;
              pcen, memwrite: out  STD_LOGIC;
              irwrite, regwrite: out STD_LOGIC;
              alusrca, iord:  out  STD_LOGIC;
              memtoreg, regdst: out STD_LOGIC;
              alusrcb, pcsrc: out  STD_LOGIC_VECTOR(1 downto 0);
              alucontrol:    out  STD_LOGIC_VECTOR(2 downto 0));
    end component;
    component datapath
        port(clk, reset:      in  STD_LOGIC;
              pcen, irwrite:  in  STD_LOGIC;
              regwrite, alusrca: in  STD_LOGIC;
              iord, memtoreg: in  STD_LOGIC;
              regdst:        in  STD_LOGIC;
              alusrcb, pcsrc: in  STD_LOGIC_VECTOR(1 downto 0);
              alucontrol:    in  STD_LOGIC_VECTOR(2 downto 0);
              readdata:      in  STD_LOGIC_VECTOR(31 downto 0);
              op, funct:     out  STD_LOGIC_VECTOR(5 downto 0);
              zero:         out  STD_LOGIC;
              adr:          out  STD_LOGIC_VECTOR(31 downto 0);
              writedata:     inout STD_LOGIC_VECTOR(31 downto 0));
    end component;
    signal zero, pcen, irwrite, regwrite, alusrca, iord, memtoreg,
            regdst: STD_LOGIC;
    signal alusrcb, pcsrc: STD_LOGIC_VECTOR(1 downto 0);
    signal alucontrol: STD_LOGIC_VECTOR(2 downto 0);
    signal op, funct: STD_LOGIC_VECTOR(5 downto 0);
begin
    c: controller port map(clk, reset, op, funct, zero,
                          pcen, memwrite, irwrite, regwrite,
                          alusrca, iord, memtoreg, regdst,
                          alusrcb, pcsrc, alucontrol);
    dp: datapath port map(clk, reset,
                          pcen, irwrite, regwrite,
                          alusrca, iord, memtoreg, regdst,
                          alusrcb, pcsrc, alucontrol,
                          readdata, op, funct, zero,
                          adr, writedata);
end;

```

MIPS Multicycle Control

SystemVerilog

```
module controller(input logic clk, reset,
                 input logic [5:0] op, funct,
                 input logic zero,
                 output logic pcen, memwrite,
                 irwrite, regwrite,
                 output logic alusrca, iord,
                 memtoreg, regdst,
                 output logic [1:0] alusrcb, pcsrc,
                 output logic [2:0] alucontrol);

    logic [1:0] aluop;
    logic branch, pcwrite;

    // Main Decoder and ALU Decoder subunits.
    maindec md(clk, reset, op,
               pcwrite, memwrite, irwrite, regwrite,
               alusrca, branch, iord, memtoreg, regdst,
               alusrcb, pcsrc, aluop);
    aludec ad(funct, aluop, alucontrol);

    assign pcen = pcwrite | (branch & zero);
endmodule
```

VHDL

```
library IEEE; use IEEE.STD_LOGIC_1164.all;
entity controller is -- multicycle control decoder
    port(clk, reset: in STD_LOGIC;
          op, funct: in STD_LOGIC_VECTOR(5 downto 0);
          zero: in STD_LOGIC;
          pcen, memwrite: out STD_LOGIC;
          irwrite, regwrite: out STD_LOGIC;
          alusrca, iord: out STD_LOGIC;
          memtoreg, regdst: out STD_LOGIC;
          alusrcb, pcsrc: out STD_LOGIC_VECTOR(1 downto 0);
          alucontrol: out STD_LOGIC_VECTOR(2 downto 0));
end;

architecture struct of controller is
    component maindec
        port(clk, reset: in STD_LOGIC;
              op: in STD_LOGIC_VECTOR(5 downto 0);
              pcwrite, memwrite: out STD_LOGIC;
              irwrite, regwrite: out STD_LOGIC;
              alusrca, branch: out STD_LOGIC;
              iord, memtoreg: out STD_LOGIC;
              regdst: out STD_LOGIC;
              alusrcb, pcsrc: out STD_LOGIC_VECTOR(1 downto 0);
              aluop: out STD_LOGIC_VECTOR(1 downto 0));
    end component;
    component aludec
        port(funct: in STD_LOGIC_VECTOR(5 downto 0);
              aluop: in STD_LOGIC_VECTOR(1 downto 0);
              alucontrol: out STD_LOGIC_VECTOR(2 downto 0));
    end component;
    signal aluop: STD_LOGIC_VECTOR(1 downto 0);
    signal branch, pcwrite: STD_LOGIC;
begin
    md: maindec port map(clk, reset, op,
                        pcwrite, memwrite, irwrite, regwrite,
                        alusrca, branch, iord, memtoreg, regdst,
                        alusrcb, pcsrc, aluop);
    ad: aludec port map(funct, aluop, alucontrol);

    pcen <= pcwrite or (branch and zero);
end;
```

MIPS Multicycle Main Decoder FSM**SystemVerilog**

```

module maindec(input logic clk, reset,
               input logic [5:0] op,
               output logic pcwrite, memwrite,
                               irwrite, regwrite,
               output logic alusrca, branch, iord,
                               memtoreg, regdst,
               output logic [1:0] alusrcb, pcsrc,
               output logic [1:0] aluop);

typedef enum logic [3:0] {FETCH, DECODE, MEMADR,
                          MEMRD, MEMWB, MEMWR, RTYPEEX,
                          RTYPEWB, BEQEX, ADDIEX,
                          ADDIWB, JEX} statetype;
statetype [3:0] state, nextstate;

parameter LW = 6'b100011; // Opcode for lw
parameter SW = 6'b101011; // Opcode for sw
parameter RTYPE = 6'b000000; // Opcode for R-type
parameter BEQ = 6'b000100; // Opcode for beq
parameter ADDI = 6'b001000; // Opcode for addi
parameter J = 6'b000010; // Opcode for j

reg [3:0] state, nextstate;
reg [14:0] controls;

// state register
always_ff @(posedge clk or posedge reset)
    if (reset) state <= FETCH;
    else state <= nextstate;

```

VHDL

```

library IEEE; use IEEE.STD_LOGIC_1164.all;
entity maindec is -- main control decoder
    port(clk, reset: in STD_LOGIC;
          op: in STD_LOGIC_VECTOR(5 downto 0);
          pcwrite, memwrite: out STD_LOGIC;
          irwrite, regwrite: out STD_LOGIC;
          alusrca, branch: out STD_LOGIC;
          iord, memtoreg: out STD_LOGIC;
          regdst: out STD_LOGIC;
          alusrcb, pcsrc: out STD_LOGIC_VECTOR(1 downto 0);
          aluop: out STD_LOGIC_VECTOR(1 downto 0));
end;

architecture behave of maindec is
    type statetype is (FETCH, DECODE, MEMADR, MEMRD, MEMWB, MEMWR,
                      RTYPEEX, RTYPEWB, BEQEX, ADDIEX, ADDIWB, JEX);
    signal state, nextstate: statetype;
    signal controls: STD_LOGIC_VECTOR(14 downto 0);
begin
    --state register
    process(clk, reset) begin
        if reset then state <= FETCH;
        elsif rising_edge(clk) then
            state <= nextstate;
        end if;
    end process;

    -- next state logic
    process(all) begin
        case state is
            when FETCH => nextstate <= DECODE;
            when DECODE =>
                case op is
                    when "100011" => nextstate <= MEMADR;
                    when "101011" => nextstate <= MEMADR;
                    when "000000" => nextstate <= RTYPEEX;
                    when "000100" => nextstate <= BEQEX;
                    when "001000" => nextstate <= ADDIEX;
                    when "000010" => nextstate <= JEX;
                    when others => nextstate <= FETCH; -- should never happen
                end case;
            when MEMADR =>
                case op is
                    when "100011" => nextstate <= MEMRD;
                    when "101011" => nextstate <= MEMWR;
                    when others => nextstate <= FETCH; -- should never happen
                end case;
            when MEMRD => nextstate <= MEMWB;
            when MEMWB => nextstate <= FETCH;
            when MEMWR => nextstate <= FETCH;
            when RTYPEEX => nextstate <= RTYPEWB;
            when RTYPEWB => nextstate <= FETCH;
            when BEQEX => nextstate <= FETCH;
            when ADDIEX => nextstate <= ADDIWB;
            when JEX => nextstate <= FETCH;
            when others => nextstate <= FETCH; -- should never happen
        end case;
    end process;

```

SystemVerilog

```
// next state logic
always_comb
case(state)
  case(op)
    FETCH: nextstate <= DECODE;
    DECODE: case(op)
      LW: nextstate <= MEMADR;
      SW: nextstate <= MEMADR;
      RTYPE: nextstate <= RTYPEEX;
      BEQ: nextstate <= BEQEX;
      ADDI: nextstate <= ADDIEX;
      J: nextstate <= JEX;
      default: nextstate <= FETCH;
      // default should never happen
    endcase
  MEMADR: case(op)
    LW: nextstate <= MEMRD;
    SW: nextstate <= MEMWR;
    default: nextstate <= FETCH;
    // default should never happen
  endcase
  MEMRD: nextstate <= MEMWB;
  MEMWB: nextstate <= FETCH;
  MEMWR: nextstate <= FETCH;
  RTYPEEX: nextstate <= RTYPEWB;
  RTYPEWB: nextstate <= FETCH;
  BEQEX: nextstate <= FETCH;
  ADDIEX: nextstate <= ADDIWB;
  ADDIWB: nextstate <= FETCH;
  JEX: nextstate <= FETCH;
  default: nextstate <= FETCH;
  // default should never happen
endcase

// output logic
assign {pcwrite, memwrite, irwrite, regwrite,
        alusrca, branch, iord, memtoreg, regdst,
        alusrcb, pcsrc, aluop} = controls;

always_comb
case (state)
  FETCH: controls <= 15'b1010_00000_0100_00;
  DECODE: controls <= 15'b0000_00000_1100_00;
  MEMADR: controls <= 15'b0000_10000_1000_00;
  MEMRD: controls <= 15'b0000_00100_0000_00;
  MEMWB: controls <= 15'b0001_00010_0000_00;
  MEMWR: controls <= 15'b0100_00100_0000_00;
  RTYPEEX: controls <= 15'b0000_10000_0000_10;
  RTYPEWB: controls <= 15'b0001_00001_0000_00;
  BEQEX: controls <= 15'b0000_11000_0001_01;
  ADDIEX: controls <= 15'b0000_10000_1000_00;
  ADDIWB: controls <= 15'b0001_00000_0000_00;
  JEX: controls <= 15'b1000_00000_0010_00;
  default: controls <= 15'b0000_xxxxx_xxxx_xx;
endcase
endmodule
```

VHDL

```
-- output logic
process(all) begin
  case state is
    when FETCH => controls <= "101000000010000";
    when DECODE => controls <= "000000000110000";
    when MEMADR => controls <= "000010000100000";
    when MEMRD => controls <= "000000100000000";
    when MEMWB => controls <= "000100010000000";
    when MEMWR => controls <= "010000100000000";
    when RTYPEEX => controls <= "000010000000010";
    when RTYPEWB => controls <= "000100001000000";
    when BEQEX => controls <= "000011000000101";
    when ADDIEX => controls <= "000010000100000";
    when ADDIWB => controls <= "000100000000000";
    when JEX => controls <= "100000000001000";
    when others => controls <= "-----"; --illegal op
  end case;
end process;

pcwrite <= controls(14);
memwrite <= controls(13);
irwrite <= controls(12);
regwrite <= controls(11);
alusrca <= controls(10);
branch <= controls(9);
iord <= controls(8);
memtoreg <= controls(7);
regdst <= controls(6);
alusrcb <= controls(5 downto 4);
pcsrc <= controls(3 downto 2);
aluop <= controls(1 downto 0);

end;
```

MIPS Multicycle ALU Decoder

SystemVerilog

```
module aludec(input logic [5:0] funct,
             input logic [1:0] aluop,
             output logic [2:0] alucontrol);

always_comb
case(aluop)
  2'b00: alucontrol <= 3'b010; // add
  2'b01: alucontrol <= 3'b110; // sub
  default: case(funct) // RTYPE
    6'b100000: alucontrol <= 3'b010; // ADD
    6'b100010: alucontrol <= 3'b110; // SUB
    6'b100100: alucontrol <= 3'b000; // AND
    6'b100101: alucontrol <= 3'b001; // OR
    6'b101010: alucontrol <= 3'b111; // SLT
    default: alucontrol <= 3'bxxx; // ???
  endcase
endcase
endmodule
```

VHDL

```
library IEEE; use IEEE.STD_LOGIC_1164.all;
entity aludec is -- ALU control decoder
  port(funct: in STD_LOGIC_VECTOR(5 downto 0);
       aluop: in STD_LOGIC_VECTOR(1 downto 0);
       alucontrol: out STD_LOGIC_VECTOR(2 downto 0));
end;

architecture behave of aludec is
begin
  process(all) begin
    case aluop is
      when "00" => alucontrol <= "010"; -- add (for lb/sb/addi)
      when "01" => alucontrol <= "110"; -- sub (for beq)
      when "11" => alucontrol <= "111"; -- slt (for slti)
      when others => case funct is -- R-type instructions
        when "100000" => alucontrol <= "010"; -- add
        when "100010" => alucontrol <= "110"; -- sub
        when "100100" => alucontrol <= "000"; -- and
        when "100101" => alucontrol <= "001"; -- or
        when "101010" => alucontrol <= "111"; -- slt
        when others => alucontrol <= "---"; -- ???
      end case;
    end case;
  end process;
end;
```

MIPS Multicycle Datapath

SystemVerilog

```

module datapath(input logic      clk, reset,
               input logic      pcen, irwrite,
               input logic      regwrite,
               input logic      alusrca, iord,
                               memtoreg, regdst,
               input logic [1:0] alusrcb, pcsrc,
               input logic [2:0] alucontrol,
               output logic [5:0] op, funct,
               output logic      zero,
               output logic [31:0] adr, writedata,
               input logic [31:0] readdata);

    // Internal signals of the datapath module.

    logic [4:0] writereg;
    logic [31:0] pcnext, pc;
    logic [31:0] instr, data, srca, srcb;
    logic [31:0] a;
    logic [31:0] aluresult, aluout;
    logic [31:0] signimm; // sign-extended immediate
    logic [31:0] signimmsh; // sign-extended immediate
                          // shifted left by 2
    logic [31:0] wd3, rd1, rd2;

    // op and funct fields to controller
    assign op = instr[31:26];
    assign funct = instr[5:0];

    // datapath
    flopenr #(32) pcreg(clk, reset, pcen, pcnext, pc);
    mux2 #(32) adrmux(pc, aluout, iord, adr);
    flopenr #(32) instrreg(clk, reset, irwrite,
                          readdata, instr);
    flopr #(32) datareg(clk, reset, readdata, data);
    mux2 #(5) regdstmux(instr[20:16], instr[15:11],
                       regdst, writereg);
    mux2 #(32) wdmux(aluout, data, memtoreg, wd3);
    regfile rf(clk, regwrite, instr[25:21],
              instr[20:16],
              writereg, wd3, rd1, rd2);
    signext se(instr[15:0], signimm);
    sl2 immsh(signimm, signimmsh);
    flopr #(32) areg(clk, reset, rd1, a);
    flopr #(32) breg(clk, reset, rd2, writedata);
    mux2 #(32) srcamux(pc, a, alusrca, srca);
    mux4 #(32) srcbmux(writedata, 32'b100,
                     signimm, signimmsh,
                     alusrcb, srcb);

    alu alu(srca, srcb, alucontrol,
           aluresult, zero);

    flopr #(32) alureg(clk, reset, aluresult, aluout);
    mux3 #(32) pcmux(aluresult, aluout,
                    {pc[31:28], instr[25:0], 2'b00},
                    pcsrc, pcnext);
endmodule
    
```

VHDL

```

library IEEE; use IEEE.STD_LOGIC_1164.all; use IEEE.STD_LOGIC_ARITH.all;
entity datapath is -- MIPS datapath
    port(clk, reset: in STD_LOGIC;
          pcen, irwrite: in STD_LOGIC;
          regwrite, alusrca: in STD_LOGIC;
          iord, memtoreg: in STD_LOGIC;
          regdst: in STD_LOGIC;
          alusrcb, pcsrc: in STD_LOGIC_VECTOR(1 downto 0);
          alucontrol: in STD_LOGIC_VECTOR(2 downto 0);
          readdata: in STD_LOGIC_VECTOR(31 downto 0);
          op, funct: out STD_LOGIC_VECTOR(5 downto 0);
          zero: out STD_LOGIC;
          adr: out STD_LOGIC_VECTOR(31 downto 0);
          writedata: inout STD_LOGIC_VECTOR(31 downto 0));
end;

architecture struct of datapath is
    component alu
        port(A, B: in STD_LOGIC_VECTOR(31 downto 0);
             F: in STD_LOGIC_VECTOR(2 downto 0);
             Y: buffer STD_LOGIC_VECTOR(31 downto 0);
             Zero: out STD_LOGIC);
    end component;
    component regfile
        port(clk: in STD_LOGIC;
             we3: in STD_LOGIC;
             ra1, ra2, wa3: in STD_LOGIC_VECTOR(4 downto 0);
             wd3: in STD_LOGIC_VECTOR(31 downto 0);
             rd1, rd2: out STD_LOGIC_VECTOR(31 downto 0));
    end component;
    component adder
        port(a, b: in STD_LOGIC_VECTOR(31 downto 0);
             y: out STD_LOGIC_VECTOR(31 downto 0));
    end component;
    component sl2
        port(a: in STD_LOGIC_VECTOR(31 downto 0);
             y: out STD_LOGIC_VECTOR(31 downto 0));
    end component;
    component signext
        port(a: in STD_LOGIC_VECTOR(15 downto 0);
             y: out STD_LOGIC_VECTOR(31 downto 0));
    end component;
    component flopr generic(width: integer)
        port(clk, reset: in STD_LOGIC;
             d: in STD_LOGIC_VECTOR(width-1 downto 0);
             g: out STD_LOGIC_VECTOR(width-1 downto 0));
    end component;
    component flopenr generic(width: integer)
        port(clk, reset: in STD_LOGIC;
             en: in STD_LOGIC;
             d: in STD_LOGIC_VECTOR(width-1 downto 0);
             g: out STD_LOGIC_VECTOR(width-1 downto 0));
    end component;
    component mux2 generic(width: integer)
        port(d0, d1: in STD_LOGIC_VECTOR(width-1 downto 0);
             s: in STD_LOGIC;
             y: out STD_LOGIC_VECTOR(width-1 downto 0));
    end component;
    component mux3 generic(width: integer)
        port(d0, d1, d2: in STD_LOGIC_VECTOR(width-1 downto 0);
             s: in STD_LOGIC_VECTOR(1 downto 0);
             y: out STD_LOGIC_VECTOR(width-1 downto 0));
    end component;
    component mux4 generic(width: integer)
        port(d0, d1, d2, d3: in STD_LOGIC_VECTOR(width-1 downto 0);
             s: in STD_LOGIC_VECTOR(1 downto 0);
             y: out STD_LOGIC_VECTOR(width-1 downto 0));
    end component;
    signal writereg: STD_LOGIC_VECTOR(4 downto 0);
    signal pcnext, pc, instr, data, srca, srcb, a,
           aluresult, aluout, signimm, signimmsh, wd3, rd1, rd2, pcjump:
           STD_LOGIC_VECTOR(31 downto 0);
end;
    
```

The following HDL describes the building blocks that are used in the MIPS multicycle processor that are not found in Section 7.6.2.

MIPS Multicycle Building Blocks

SystemVerilog

```

module flopenr #(parameter WIDTH = 8)
    (input logic          clk, reset,
     input logic          en,
     input logic [WIDTH-1:0] d,
     output logic [WIDTH-1:0] q);

    always_ff @(posedge clk, posedge reset)
        if (reset) q <= 0;
        else if (en) q <= d;
endmodule

module mux3 #(parameter WIDTH = 8)
    (input logic [WIDTH-1:0] d0, d1, d2,
     input logic [1:0] s,
     output logic [WIDTH-1:0] y);

    assign #1 y = s[1] ? d2 : (s[0] ? d1 : d0);
endmodule

module mux4 #(parameter WIDTH = 8)
    (input logic [WIDTH-1:0] d0, d1, d2, d3,
     input logic [1:0] s,
     output logic [WIDTH-1:0] y);

    always_comb
        case(s)
            2'b00: y <= d0;
            2'b01: y <= d1;
            2'b10: y <= d2;
            2'b11: y <= d3;
        endcase
endmodule
    
```

VHDL

```

library IEEE; use IEEE.STD_LOGIC_1164.all; use IEEE.STD_LOGIC_ARITH.all;
entity flopenr is -- flip-flop with asynchronous reset
    generic(width: integer);
    port(clk, reset: in STD_LOGIC;
         en: in STD_LOGIC;
         d: in STD_LOGIC_VECTOR(width-1 downto 0);
         q: out STD_LOGIC_VECTOR(width-1 downto 0));
end;

architecture asynchronous of flopenr is
begin
    process(clk, reset) begin
        if reset then q <= CONV_STD_LOGIC_VECTOR(0, width);
        elsif rising_edge(clk) and en = '1' then
            q <= d;
        end if;
    end process;
end;

library IEEE; use IEEE.STD_LOGIC_1164.all;
entity mux3 is -- three-input multiplexer
    generic(width: integer);
    port(d0, d1, d2: in STD_LOGIC_VECTOR(width-1 downto 0);
         s: in STD_LOGIC_VECTOR(1 downto 0);
         y: out STD_LOGIC_VECTOR(width-1 downto 0));
end;

architecture behave of mux3 is
begin
    process(all) begin
        case s is
            when "00" => y <= d0;
            when "01" => y <= d1;
            when "10" => y <= d2;
            when others => y <= d0;
        end case;
    end process;
end;

library IEEE; use IEEE.STD_LOGIC_1164.all;
entity mux4 is -- four-input multiplexer
    generic(width: integer);
    port(d0, d1, d2, d3: in STD_LOGIC_VECTOR(width-1 downto 0);
         s: in STD_LOGIC_VECTOR(1 downto 0);
         y: out STD_LOGIC_VECTOR(width-1 downto 0));
end;

architecture behave of mux4 is
begin
    process(all) begin
        case s is
            when "00" => y <= d0;
            when "01" => y <= d1;
            when "10" => y <= d2;
            when "11" => y <= d3;
            when others => y <= d0; -- should never happen
        end case;
    end process;
end;
    
```

Exercise 7.27

We modify the MIPS multicycle processor to implement all instructions from Exercise 7.14.

SystemVerilog

```
module top(input logic clk, reset,
           output logic [31:0] writedata, dataadr,
           output logic memwrite);

    logic [31:0] pc, instr, readdata;

    // instantiate processor and memories
    mips mips(clk, reset, pc, instr, memwrite, dataadr,
             writedata, readdata);
    imem imem(pc[7:2], instr);
    dmem dmem(clk, memwrite, dataadr, writedata, readdata);
endmodule

module dmem(input logic clk, we,
            input logic [31:0] a, wd,
            output logic [31:0] rd);

    logic [31:0] RAM[63:0];

    assign rd = RAM[a[31:2]]; // word aligned

    always_ff @(posedge clk)
        if (we) RAM[a[31:2]] <= wd;
endmodule

module imem(input logic [5:0] a,
            output logic [31:0] rd);

    logic [31:0] RAM[63:0];

    initial
        $readmemh("memfile.dat",RAM);

    assign rd = RAM[a]; // word aligned
endmodule

module top(input logic clk, reset,
           output logic [31:0] writedata, adr,
           output logic memwrite);

    logic [31:0] readdata;

    // instantiate processor and memory
    mips mips(clk, reset, adr, writedata, memwrite,
             readdata);
    mem mem(clk, memwrite, adr, writedata,
            readdata);
endmodule

module mips(input logic clk, reset,
            output logic [31:0] adr, writedata,
            output logic memwrite,
            input logic [31:0] readdata);
```

```

        logic zero, pcen, irwrite, regwrite,
            alusrca, iord, memtoreg, regdst;
        logic [2:0] alusrcb; // ANDI
        logic [1:0] pcsrc;
        logic [2:0] alucontrol;
        logic [5:0] op, funct;
        logic [1:0] lb; // LB/LBU

        controller c(clk, reset, op, funct, zero,
            pcen, memwrite, irwrite, regwrite,
            alusrca, iord, memtoreg, regdst,
            alusrcb, pcsrc, alucontrol, lb); // LB/LBU
    datapath dp(clk, reset,
        pcen, irwrite, regwrite,
        alusrca, iord, memtoreg, regdst,
        alusrcb, pcsrc, alucontrol,
        lb, // LB/LBU
        op, funct, zero,
        adr, writedata, readdata);
endmodule

module controller(input logic clk, reset,
    input logic [5:0] op, funct,
    input logic zero,
    output logic pcen, memwrite,
        irwrite, regwrite,
    output logic alusrca, iord,
        memtoreg, regdst,
    output logic [2:0] alusrcb, // ANDI
    output logic [1:0] pcsrc,
    output logic [2:0] alucontrol,
    output logic [1:0] lb); // LB/LBU

    logic [1:0] aluop;
    logic branch, pcwrite;
    logic bne; // BNE

    // Main Decoder and ALU Decoder subunits.
    maindec md(clk, reset, op,
        pcwrite, memwrite, irwrite, regwrite,
        alusrca, branch, iord, memtoreg, regdst,
        alusrcb, pcsrc, aluop, bne, lb); //BNE, LBU
    aludec ad(funct, aluop, alucontrol);

    assign pcen = pcwrite | (branch & zero) |
        (bne & ~zero); // BNE
endmodule

module maindec(input clk, reset,
    input [5:0] op,
    output pcwrite, memwrite,
        irwrite, regwrite,
    output alusrca, branch,
        iord, memtoreg, regdst,
    output [2:0] alusrcb, // ANDI
    output [1:0] pcsrc,
    output [1:0] aluop,
    output bne, // BNE
    output [1:0] lb); // LB/LBU

    typedef enum logic [4:0] {FETCH, DECODE, MEMADR,
        MEMRD, MEMWB, MEMWR, RTYPEEX, RTYPEWB, BEQEX,
        ADDIEX, ADDIWB, JEX, ANDIEX, ANDIWB,
        BNEEX, LBRD, LBRD} statetype;

```

```

statetype [4:0] state, nextstate;

parameter RTYPE = 6'b000000;
parameter LW = 6'b100011;
parameter SW = 6'b101011;
parameter BEQ = 6'b000100;
parameter ADDI = 6'b001000;
parameter J = 6'b000010;
parameter BNE = 6'b000101;
parameter LBU = 6'b100100;
parameter LB = 6'b100000;
parameter ANDI = 6'b001100;

logic [18:0] controls; // ANDI, BNE, LBU

// state register
always_ff @(posedge clk or posedge reset)
    if(reset) state <= FETCH;
    else state <= nextstate;

// next state logic
always_comb
    case(state)
        FETCH: nextstate <= DECODE;
        DECODE: case(op)
            LW: nextstate <= MEMADR;
            SW: nextstate <= MEMADR;
            LB: nextstate <= MEMADR; // LB
            LBU: nextstate <= MEMADR; // LBU
            RTYPE: nextstate <= RTYPEEX;
            BEQ: nextstate <= BEQEX;
            ADDI: nextstate <= ADDIEX;
            J: nextstate <= JEX;
            BNE: nextstate <= BNEEX; // BNE
            ANDI: nextstate <= ADDIEX; // ANDI
            default: nextstate <= FETCH;
                // should never happen
        endcase
        MEMADR: case(op)
            LW: nextstate <= MEMRD;
            SW: nextstate <= MEMWR;
            LBU: nextstate <= LBURD; // LBU
            LB: nextstate <= LBRD; // LB
            default: nextstate <= FETCH;
                // should never happen
        endcase
        MEMRD: nextstate <= MEMWB;
        MEMWB: nextstate <= FETCH;
        MEMWR: nextstate <= FETCH;
        RTYPEEX: nextstate <= RTYPEWB;
        RTYPEWB: nextstate <= FETCH;
        BEQEX: nextstate <= FETCH;
        ADDIEX: nextstate <= ADDIWB;
        ADDIWB: nextstate <= FETCH;
        JEX: nextstate <= FETCH;
        ANDIEX: nextstate <= ANDIWB; // ANDI
        ANDIWB: nextstate <= FETCH; // ANDI
        BNEEX: nextstate <= FETCH; // BNE
        LBURD: nextstate <= MEMWB; // LBU
        LBRD: nextstate <= MEMWB; // LB
        default: nextstate <= FETCH;
            // should never happen
    endcase

// output logic

```

```

assign {pcwrite, memwrite, irwrite, regwrite,
       alusrca, branch, iord, memtoreg, regdst,
       bne, // BNE
       alusrcb, pcsrc,
       aluop,
       lb} = controls; // LBU

always_comb
case(state)
FETCH:   controls <= 19'b1010_00000_0_00100_00_00;
DECODE:  controls <= 19'b0000_00000_0_01100_00_00;
MEMADR:  controls <= 19'b0000_10000_0_01000_00_00;
MEMRD:   controls <= 19'b0000_00100_0_00000_00_00;
MEMWB:   controls <= 19'b0001_00010_0_00000_00_00;
MEMWR:   controls <= 19'b0100_00100_0_00000_00_00;
RTYPEEX: controls <= 19'b0000_10000_0_00000_10_00;
RTYPEWB: controls <= 19'b0001_00001_0_00000_00_00;
BEQEX:   controls <= 19'b0000_11000_0_00001_01_00;
ADDIEX:  controls <= 19'b0000_10000_0_01000_00_00;
ADDIWB:  controls <= 19'b0001_00000_0_00000_00_00;
JEX:     controls <= 19'b1000_00000_0_00010_00_00;
ANDIEX:  controls <= 19'b0000_10000_0_10000_11_00; // ANDI
ANDIWB:  controls <= 19'b0001_00000_0_00000_00_00; // ANDI
BNEEX:   controls <= 19'b0000_10000_1_00001_01_00; // BNE
LBURD:   controls <= 19'b0000_00100_0_00000_00_01; // LBU
LBRD:    controls <= 19'b0000_00100_0_00000_00_10; // LB
default:  controls <= 19'b0000_xxxxx_x_xxxxxx_xx_xx;
           // should never happen
endcase
endmodule

module aludec(input  logic [5:0] funct,
             input  logic [1:0] aluop,
             output logic [2:0] alucontrol);

always_comb
case(aluop)
2'b00: alucontrol <= 3'b010; // add
2'b01: alucontrol <= 3'b110; // sub
2'b11: alucontrol <= 3'b000; // and
2'b10: case(funct) // RTYPE
6'b100000: alucontrol <= 3'b010; // ADD
6'b100010: alucontrol <= 3'b110; // SUB
6'b100100: alucontrol <= 3'b000; // AND
6'b100101: alucontrol <= 3'b001; // OR
6'b101010: alucontrol <= 3'b111; // SLT
default:   alucontrol <= 3'bxxx; // ???
endcase
default: alucontrol <= 3'bxxx; // ???
endcase
endmodule

module datapath(input  logic      clk, reset,
               input  logic      pcen, irwrite,
               input  logic      regwrite,
               input  logic      alusrca, iord,
                               memtoreg, regdst,
               input  logic [2:0] alusrcb, // ANDI
               input  logic [1:0] pcsrc,
               input  logic [2:0] alucontrol,
               input  logic [1:0] lb, // LB/LBU
               output logic [5:0] op, funct,
               output logic      zero,
               output logic [31:0] adr, writedata,
               input  logic [31:0] readdata);

```

```
// Internal signals of the datapath module

logic [4:0] writereg;
logic [31:0] pcnext, pc;
logic [31:0] instr, data, srca, srcb;
logic [31:0] a;
logic [31:0] aluresult, aluout;
logic [31:0] signimm; // the sign-extended imm
logic [31:0] zeroimm; // the zero-extended imm
// ANDI
logic [31:0] signimmsh; // the sign-extended imm << 2
logic [31:0] wd3, rd1, rd2;
logic [31:0] memdata, membytezext, membytesext; // LB / LBU
logic [7:0] membyte; // LB / LBU

// op and funct fields to controller
assign op = instr[31:26];
assign funct = instr[5:0];

// datapath
flopnr #(32) pcreg(clk, reset, pcen, pcnext, pc);
mux2 #(32) adrmux(pc, aluout, iord, adr);
flopnr #(32) instrreg(clk, reset, irwrite,
                    readdata, instr);

// changes for LB / LBU
flopnr #(32) datareg(clk, reset, memdata, data);
mux4 #(8) lbmux(readdata[31:24],
               readdata[23:16], readdata[15:8],
               readdata[7:0], aluout[1:0],
               membyte);
zeroext8_32 lbze(membyte, membytezext);
signext8_32 lbse(membyte, membytesext);
mux3 #(32) datamux(readdata, membytezext, membytesext,
                  lb, memdata);

mux2 #(5) regdstmux(instr[20:16],
                   instr[15:11], regdst, writereg);
mux2 #(32) wdmux(aluout, data, memtoreg, wd3);
regfile rf(clk, regwrite, instr[25:21],
           instr[20:16],
           writereg, wd3, rd1, rd2);
signext se(instr[15:0], signimm);
zeroext ze(instr[15:0], zeroimm); // ANDI
sl2 immsh(signimm, signimmsh);
flopnr #(32) areg(clk, reset, rd1, a);
flopnr #(32) breg(clk, reset, rd2, writedata);
mux2 #(32) srcmux(pc, a, alusrca, srca);
mux5 #(32) srcbmux(writedata, 32'b100,
                  signimm, signimmsh,
                  zeroimm, // ANDI
                  alusrca, srcb);

alu alu(srca, srcb, alucontrol, aluresult, zero);
flopnr #(32) alureg(clk, reset, aluresult, aluout);
mux3 #(32) pcmux(aluresult, aluout,
                {pc[31:28], instr[25:0], 2'b00},
                pcsrca, pcnext);

endmodule

module alu(input logic [31:0] A, B,
          input logic [2:0] F,
          output logic [31:0] Y, output Zero);
```

```
logic [31:0] S, Bout;

assign Bout = F[2] ? ~B : B;
assign S = A + Bout + F[2];

always_comb
  case (F[1:0])
    3'b00: Y <= A & Bout;
    3'b01: Y <= A | Bout;
    3'b10: Y <= S;
    3'b11: Y <= S[31];
  endcase

assign Zero = (Y == 32'b0);
endmodule

// mux5 is needed for ANDI
module mux5 #(parameter WIDTH = 8)
  (input [WIDTH-1:0] d0, d1, d2, d3, d4,
   input [2:0] s,
   output reg [WIDTH-1:0] y);

  always_comb
    case(s)
      3'b000: y <= d0;
      3'b001: y <= d1;
      3'b010: y <= d2;
      3'b011: y <= d3;
      3'b100: y <= d4;
    endcase
endmodule

// zeroext is needed for ANDI
module zeroext(input [15:0] a,
               output [31:0] y);

  assign y = {16'b0, a};
endmodule

// zeroext8_32 is needed for LBU
module zeroext8_32(input logic [7:0] a,
                  output logic [31:0] y);

  assign y = {24'b0, a};
endmodule

// signext8_32 is needed for LB
module signext8_32(input logic [7:0] a,
                  output logic [31:0] y);

  assign y = {{24{a[7]}}, a};
endmodule

module alu(input logic [31:0] A, B,
           input logic [3:0] F,
           input logic [4:0] shamt, // SRL
           output logic [31:0] Y,
           output logic Zero);

  logic [31:0] S, Bout;

  assign Bout = F[3] ? ~B : B;
  assign S = A + Bout + F[3]; // SRL
```



```
always_comb
  case (F[2:0])
    3'b000: Y = A & Bout;
    3'b001: Y = A | Bout;
    3'b010: Y = S;
    3'b011: Y = S[31];
    3'b100: Y = (Bout >> shamt); // SRL
  endcase

assign Zero = (Y == 32'b0);

endmodule

module regfile(input logic clk,
               input logic we3,
               input logic [4:0] ra1, ra2, wa3,
               input logic [31:0] wd3,
               output logic [31:0] rd1, rd2);

  logic [31:0] rf[31:0];

  // three ported register file
  // read two ports combinatorially
  // write third port on rising edge of clk
  // register 0 hardwired to 0
  always_ff @(posedge clk)
    if (we3) rf[wa3] <= wd3;

  assign rd1 = (ra1 != 0) ? rf[ra1] : 0;
  assign rd2 = (ra2 != 0) ? rf[ra2] : 0;
endmodule

module adder(input logic [31:0] a, b,
             output logic [31:0] y);

  assign y = a + b;
endmodule

module sl2(input logic [31:0] a,
           output logic [31:0] y);

  // shift left by 2
  assign y = {a[29:0], 2'b00};
endmodule

module signext(input logic [15:0] a,
               output logic [31:0] y);

  assign y = {{16{a[15]}}, a};
endmodule

module flopr #(parameter WIDTH = 8)
  (input logic clk, reset,
   input logic [WIDTH-1:0] d,
   output logic [WIDTH-1:0] q);

  always_ff @(posedge clk, posedge reset)
    if (reset) q <= 0;
    else      q <= d;
endmodule

module mux2 #(parameter WIDTH = 8)
  (input logic [WIDTH-1:0] d0, d1,
   input logic s,
   output logic [WIDTH-1:0] y);
```



```

library IEEE; use IEEE.STD_LOGIC_1164.all;
entity controller is -- multicycle control decoder
  port(clk, reset:      in  STD_LOGIC;
        op, funct:     in  STD_LOGIC_VECTOR(5 downto 0);
        zero:          in  STD_LOGIC;
        pcen, memwrite: out STD_LOGIC;
        irwrite, regwrite: out STD_LOGIC;
        alusrca, iord:  out STD_LOGIC;
        memtoreg, regdst: out STD_LOGIC;
        alusrcb:       out STD_LOGIC_VECTOR(2 downto 0); --andi
        pcsrc:         out STD_LOGIC_VECTOR(1 downto 0);
        alucontrol:    out STD_LOGIC_VECTOR(2 downto 0);
        lb:            out STD_LOGIC_VECTOR(1 downto 0)); --lb, lbu
end;
architecture struct of controller is
  component maindec
    port(clk, reset:      in  STD_LOGIC;
          op:             in  STD_LOGIC_VECTOR(5 downto 0);
          pcwrite, memwrite: out STD_LOGIC;
          irwrite, regwrite: out STD_LOGIC;
          alusrca, branch:  out STD_LOGIC;
          iord, memtoreg:  out STD_LOGIC;
          regdst:          out STD_LOGIC;
          alusrcb:         out STD_LOGIC_VECTOR(2 downto 0); --andi
          pcsrc:           out STD_LOGIC_VECTOR(1 downto 0);
          aluop:           out STD_LOGIC_VECTOR(1 downto 0);
          lb:              out STD_LOGIC_VECTOR(1 downto 0)); --lb / lbu
  end component;
  component aludec
    port(funct:      in  STD_LOGIC_VECTOR(5 downto 0);
          aluop:     in  STD_LOGIC_VECTOR(1 downto 0);
          alucontrol: out STD_LOGIC_VECTOR(2 downto 0));
  end component;
  signal aluop: STD_LOGIC_VECTOR(1 downto 0);
  signal branch, pcwrite, bne: STD_LOGIC; --bne
begin
  md: maindec port map(clk, reset, op,
                      pcwrite, memwrite, irwrite, regwrite,
                      alusrca, branch, iord, memtoreg, regdst,
                      alusrcb, pcsrc, aluop, bne, lb); --bne, lb
  ad: aludec port map(funct, aluop, alucontrol);

  pcen <= pcwrite or (branch and zero) or (bne and (not zero)); --bne
end;

```

```

library IEEE; use IEEE.STD_LOGIC_1164.all;
entity maindec is -- main control decoder
  port(clk, reset:      in  STD_LOGIC;
        op:             in  STD_LOGIC_VECTOR(5 downto 0);
        pcwrite, memwrite: out STD_LOGIC;
        irwrite, regwrite: out STD_LOGIC;
        alusrca, branch:  out STD_LOGIC;
        iord, memtoreg:  out STD_LOGIC;
        regdst:          out STD_LOGIC;
        alusrcb:         out STD_LOGIC_VECTOR(2 downto 0); --andi
        pcsrc:           out STD_LOGIC_VECTOR(1 downto 0);
        aluop:           out STD_LOGIC_VECTOR(1 downto 0);
        bne:             out STD_LOGIC; --bne
        aluop:           out STD_LOGIC_VECTOR(1 downto 0)); --lb / lbu
end;

architecture behave of maindec is
  type statetype is (FETCH, DECODE, MEMADR, MEMRD, MEMWB, MEMWR,
                    RTYPEEX, RTYPEWB, BEQEX, ADDIEX, ADDIWB, JEX,

```

```

        ANDIEX, ANDIWB, BNEEX, LBURD, LBRD);
    signal state, nextstate: statetype;
    signal controls: STD_LOGIC_VECTOR(18 downto 0);
begin
    --state register
    process(clk, reset) begin
        if reset then state <= FETCH;
        elsif rising_edge(clk) then
            state <= nextstate;
        end if;
    end process;

    -- next state logic
    process(all) begin
        case state is
            when FETCH =>          nextstate <= DECODE;
            when DECODE =>
                case op is
                    when "100011" => nextstate <= MEMADR; --LW
                    when "101011" => nextstate <= MEMADR; --SW
                    when "100000" => nextstate <= MEMADR; --LB
                    when "100100" => nextstate <= MEMADR; --LBU
                    when "000000" => nextstate <= RTYPEEX; --RTYPE
                    when "000100" => nextstate <= BEQEX;  --BEQ
                    when "001000" => nextstate <= ADDIEX; --ADDI
                    when "000010" => nextstate <= JEX;    --J
                    when "000101" => nextstate <= ORIEX;  --BNE
                    when "001100" => nextstate <= ORIEX;  --ANDI
                    when others => nextstate <= FETCH; -- should never happen
                end case;
            when MEMADR =>
                case op is
                    when "100011" => nextstate <= MEMRD;
                    when "101011" => nextstate <= MEMWR;
                    when "100000" => nextstate <= LBRD;  --LB
                    when "100100" => nextstate <= LBURD; --LBU
                    when others => nextstate <= FETCH; -- should never happen
                end case;
            when MEMRD =>          nextstate <= MEMWB;
            when MEMWB =>          nextstate <= FETCH;
            when MEMWR =>          nextstate <= FETCH;
            when RTYPEEX =>        nextstate <= RTYPEWB;
            when RTYPEWB =>        nextstate <= FETCH;
            when BEQEX =>          nextstate <= FETCH;
            when ADDIEX =>         nextstate <= ADDIWB;
            when JEX =>            nextstate <= FETCH;
            when ANDIEX =>         nextstate <= ANDIWB; // ANDI
            when ANDIWB =>         nextstate <= FETCH; // ANDI
            when BNEEX =>          nextstate <= FETCH; // BNE
            when LBURD =>          nextstate <= MEMWB; // LBU
            when LBRD =>           nextstate <= MEMWB; // LB
            when others =>         nextstate <= FETCH; -- should never happen
        end case;
    end process;

    -- output logic
    process(all) begin
        case state is
            when FETCH => controls <= "1010_00000_0_00100_00_00";
            when DECODE => controls <= "0000_00000_0_01100_00_00";
            when MEMADR => controls <= "0000_10000_0_01000_00_00";
            when MEMRD => controls <= "0000_00100_0_00000_00_00";
            when MEMWB => controls <= "0001_00010_0_00000_00_00";
            when MEMWR => controls <= "0100_00100_0_00000_00_00";
            when RTYPEEX => controls <= "0000_10000_0_00000_10_00";
            when RTYPEWB => controls <= "0001_00001_0_00000_00_00";
        end case;
    end process;
end

```

```

    when BEQEX => controls <= "0000_11000_0_00001_01_00";
    when ADDIEX => controls <= "0000_10000_0_01000_00_00";
    when ADDIWB => controls <= "0001_00000_0_00000_00_00";
    when JEX => controls <= "1000_00000_0_00010_00_00";
    when ANDIEX => controls <= "0000_10000_0_10000_11_00";
    when ANDIWB => controls <= "0001_00000_0_00000_00_00";
    when BNEEX => controls <= "0000_10000_1_00001_01_00";
    when LBURD => controls <= "0000_00100_0_00000_00_01";
    when LBRD => controls <= "0000_00100_0_00000_00_10";
    when others => controls <= "0000_-----_--_-----_--_--";
                                                    --illegal op
end case;
end process;

pcwrite <= controls(18);
memwrite <= controls(17);
irwrite <= controls(16);
regwrite <= controls(15);
alusrca <= controls(14);
branch <= controls(13);
iord <= controls(12);
memtoreg <= controls(11);
regdst <= controls(10);
bne <= controls(9);
alusrcb <= controls(8 downto 6);
pcsrc <= controls(5 downto 4);
aluop <= controls(3 downto 1);
lb <= controls(0);

end;

library IEEE; use IEEE.STD_LOGIC_1164.all;
entity aludec is -- ALU control decoder
    port(funct:      in  STD_LOGIC_VECTOR(5 downto 0);
         aluop:     in  STD_LOGIC_VECTOR(1 downto 0);
         alucontrol: out STD_LOGIC_VECTOR(2 downto 0));
end;

architecture behave of aludec is
begin
    process(all) begin
        case aluop is
            when "00" => alucontrol <= "010"; -- add (for lb/sb/addi)
            when "01" => alucontrol <= "110"; -- sub (for beq)
            when "11" => alucontrol <= "000"; -- and (for andi)
            when others => case funct is
                                -- R-type instructions
                                when "100000" => alucontrol <= "010"; -- add
                                when "100010" => alucontrol <= "110"; -- sub
                                when "100100" => alucontrol <= "000"; -- and
                                when "100101" => alucontrol <= "001"; -- or
                                when "101010" => alucontrol <= "111"; -- slt
                                when others => alucontrol <= "----"; -- ???
                            end case;
        end case;
    end process;
end;

library IEEE; use IEEE.STD_LOGIC_1164.all; use IEEE.STD_LOGIC_ARITH.all;
entity datapath is -- MIPS datapath
    port(clk, reset:      in  STD_LOGIC;
         pcen, irwrite:   in  STD_LOGIC;
         regwrite, alusrca: in STD_LOGIC;
         iord, memtoreg:  in  STD_LOGIC;
         regdst:         in  STD_LOGIC);
end;

```

```

        alusrcb:      in  STD_LOGIC_VECTOR(2 downto 0); --andi
        pcsrc:       in  STD_LOGIC_VECTOR(1 downto 0);
        alucontrol:  in  STD_LOGIC_VECTOR(2 downto 0);
        lb:          in  STD_LOGIC_VECTOR(1 downto 0); --lb / lbu
        readdata:    in  STD_LOGIC_VECTOR(31 downto 0);
        op, funct:   out STD_LOGIC_VECTOR(5 downto 0);
        zero:        out STD_LOGIC;
        adr:         out STD_LOGIC_VECTOR(31 downto 0);
        writedata:   inout STD_LOGIC_VECTOR(31 downto 0));
    end;

architecture struct of datapath is
    component alu
        port(A, B:    in  STD_LOGIC_VECTOR(31 downto 0);
             F:      in  STD_LOGIC_VECTOR(2 downto 0);
             Y:      out STD_LOGIC_VECTOR(31 downto 0);
             Zero:   out STD_LOGIC);
    end component;
    component regfile
        port(clk:    in  STD_LOGIC;
             we3:    in  STD_LOGIC;
             ra1, ra2, wa3: in STD_LOGIC_VECTOR(4 downto 0);
             wd3:    in  STD_LOGIC_VECTOR(31 downto 0);
             rd1, rd2: out STD_LOGIC_VECTOR(31 downto 0));
    end component;
    component adder
        port(a, b: in  STD_LOGIC_VECTOR(31 downto 0);
             y:   out STD_LOGIC_VECTOR(31 downto 0));
    end component;
    component s12
        port(a: in  STD_LOGIC_VECTOR(31 downto 0);
             y: out STD_LOGIC_VECTOR(31 downto 0));
    end component;
    component signext
        port(a: in  STD_LOGIC_VECTOR(15 downto 0);
             y: out STD_LOGIC_VECTOR(31 downto 0));
    end component;
    component zeroext
        port(a: in  STD_LOGIC_VECTOR(15 downto 0);
             y: out STD_LOGIC_VECTOR(31 downto 0));
    end component;
    component flopr generic(width: integer);
        port(clk, reset: in  STD_LOGIC;
             d:         in  STD_LOGIC_VECTOR(width-1 downto 0);
             q:         out STD_LOGIC_VECTOR(width-1 downto 0));
    end component;
    component flopenr generic(width: integer);
        port(clk, reset: in  STD_LOGIC;
             en:        in  STD_LOGIC;
             d:         in  STD_LOGIC_VECTOR(width-1 downto 0);
             q:         out STD_LOGIC_VECTOR(width-1 downto 0));
    end component;
    component mux2 generic(width: integer);
        port(d0, d1: in  STD_LOGIC_VECTOR(width-1 downto 0);
             s:     in  STD_LOGIC;
             y:     out STD_LOGIC_VECTOR(width-1 downto 0));
    end component;
    component mux3 generic(width: integer);
        port(d0, d1, d2: in  STD_LOGIC_VECTOR(width-1 downto 0);
             s:         in  STD_LOGIC_VECTOR(1 downto 0);
             y:         out STD_LOGIC_VECTOR(width-1 downto 0));
    end component;
    component mux4 generic(width: integer);
        port(d0, d1, d2, d3: in  STD_LOGIC_VECTOR(width-1 downto 0);
             s:             in  STD_LOGIC_VECTOR(1 downto 0);
             y:             out STD_LOGIC_VECTOR(width-1 downto 0));
    end component;
end architecture struct;

```

```

end component;
component mux5 generic(width: integer);
  port(d0, d1, d2, d3, d4: in STD_LOGIC_VECTOR(width-1 downto 0);
        s:             in STD_LOGIC_VECTOR(2 downto 0);
        y:             out STD_LOGIC_VECTOR(width-1 downto 0));
end component;
-- lb / lbu
component zeroext8_32
  port(a: in STD_LOGIC_VECTOR(7 downto 0);
        y: out STD_LOGIC_VECTOR(31 downto 0));
end component;
component signext8_32
  port(a: in STD_LOGIC_VECTOR(7 downto 0);
        y: out STD_LOGIC_VECTOR(31 downto 0));
end component;

signal writereg: STD_LOGIC_VECTOR(4 downto 0);
signal pcnext, pc, instr, data, srca, srcb, a,
      aluresult, aluout, signimm, signimmsh, wd3, rd1, rd2, pejump:
      STD_LOGIC_VECTOR(31 downto 0);

-- lb / lbu
signal memdata, membytezext, membytesext: STD_LOGIC_VECTOR(31 downto 0);
signal membyte: STD_LOGIC_VECTOR(7 downto 0);

begin
-- op and funct fields to controller
op <= instr(31 downto 26);
funct <= instr(5 downto 0);

-- datapath
pcreg: flopenr generic map(32) port map(clk, reset, pcen, pcnext, pc);
adrmux: mux2 generic map(32) port map(pc, aluout, iord, adr);
instrreg: flopenr generic map(32) port map(clk, reset, irwrite,
      readdata, instr);

-- changes for lb / lbu
datareg: flopr generic map(32) port map(clk, reset, memdata, data);
lbmux: mux4 generic map(8) port map(readdata(31 downto 24),
      readdata(23 downto 16),
      readdata(15 downto 8),
      readdata(7 downto 0),
      aluout(1 downto 0), membyte);
lbze: zeroext8_32 port map(membyte, membytezext);
lbse: signext8_32 port map(membyte, membytesext);
datamux: mux3 generic map(32) port map(readdata, membytezext, membytesext,
      lb, memdata);

datareg: flopr generic map(32) port map(clk, reset, readdata, data);
regdstmux: mux2 generic map(5) port map(instr(20 downto 16),
      instr(15 downto 11),
      regdst, writereg);
wdmux: mux2 generic map(32) port map(aluout, data, memtoreg, wd3);
rf: regfile port map(clk, regwrite, instr(25 downto 21),
      instr(20 downto 16),
      writereg, wd3, rd1, rd2);
se: signext port map(instr(15 downto 0), signimm);
ze: zeroext port map(instr(15 downto 0), zeroimm); --andi
immsh: sl2 port map(signimm, signimmsh);
areg: flopr generic map(32) port map(clk, reset, rd1, a);
breg: flopr generic map(32) port map(clk, reset, rd2, writedata);
srcamux: mux2 generic map(32) port map(pc, a, alusrca, srca);
srcbmux: mux5 generic map(32) port map(writedata,
      "00000000000000000000000000000100",
      signimm, signimmsh, zeroimm, alusrca, srcb); --andi
alu32: alu port map(srca, srcb, alucontrol, aluresult, zero);
alureg: flopr generic map(32) port map(clk, reset, aluresult, aluout);

```

```
pcjump <= pc(31 downto 28)&instr(25 downto 0)&"00";
pcmux: mux3 generic map(32) port map(aluresult, aluout,
                                     pcjump, pcsrc, pcnext);
end;

library IEEE; use IEEE.STD_LOGIC_1164.all; use IEEE.STD_LOGIC_ARITH.all;
entity flopenr is -- flip-flop with asynchronous reset
  generic(width: integer);
  port(clk, reset: in STD_LOGIC;
        en:         in STD_LOGIC;
        d:          in STD_LOGIC_VECTOR(width-1 downto 0);
        q:          out STD_LOGIC_VECTOR(width-1 downto 0));
end;

architecture asynchronous of flopenr is
begin
  process(clk, reset) begin
    if reset then q <= CONV_STD_LOGIC_VECTOR(0, width);
    elsif rising_edge(clk) and en = '1' then
      q <= d;
    end if;
  end process;
end;

library IEEE; use IEEE.STD_LOGIC_1164.all;
entity mux3 is -- three-input multiplexer
  generic(width: integer);
  port(d0, d1, d2: in STD_LOGIC_VECTOR(width-1 downto 0);
        s:         in STD_LOGIC_VECTOR(1 downto 0);
        y:         out STD_LOGIC_VECTOR(width-1 downto 0));
end;

architecture behave of mux3 is
begin
  process(all) begin
    case s is
      when "00" => y <= d0;
      when "01" => y <= d1;
      when "10" => y <= d2;
      when others => y <= d0;
    end case;
  end process;
end;

library IEEE; use IEEE.STD_LOGIC_1164.all;
entity mux4 is -- four-input multiplexer
  generic(width: integer);
  port(d0, d1, d2, d3: in STD_LOGIC_VECTOR(width-1 downto 0);
        s:             in STD_LOGIC_VECTOR(1 downto 0);
        y:             out STD_LOGIC_VECTOR(width-1 downto 0));
end;

architecture behave of mux4 is
begin
  process(all) begin
    case s is
      when "00" => y <= d0;
      when "01" => y <= d1;
      when "10" => y <= d2;
      when "11" => y <= d3;
      when others => y <= d0; -- should never happen
    end case;
  end process;
end;
```



```
end;

library IEEE; use IEEE.STD_LOGIC_1164.all;
entity mux5 is -- five-input multiplexer
  generic(width: integer);
  port(d0, d1, d2, d3, d4: in  STD_LOGIC_VECTOR(width-1 downto 0);
        s:                    in  STD_LOGIC_VECTOR(2 downto 0);
        y:                    out STD_LOGIC_VECTOR(width-1 downto 0));
end;
architecture behave of mux5 is
begin
  process(all) begin
    case s is
      when "000" => y <= d0;
      when "001" => y <= d1;
      when "010" => y <= d2;
      when "011" => y <= d3;
      when "100" => y <= d4;
      when others => y <= d0; -- should never happen
    end case;
  end process;
end;
```

```
library IEEE;
use IEEE.STD_LOGIC_1164.all;
use IEEE.std_logic_arith.all;
use ieee.std_logic_unsigned.all;

entity alu is
  port(A, B:    in  STD_LOGIC_VECTOR(31 downto 0);
        F:      in  STD_LOGIC_VECTOR(2 downto 0);
        Y:      out STD_LOGIC_VECTOR(31 downto 0);
        Zero:   out STD_LOGIC);
end;

architecture synth of alu is
  signal S, Bout:    STD_LOGIC_VECTOR(31 downto 0);
begin
  Bout <= (not B) when (F(3) = '1') else B;
  S <= A + Bout + F(3);
  Zero <= '1' when (Y = X"00000000") else '0';

  process(all) begin
    case F(1 downto 0) is
      when "00" => Y <= A and Bout;
      when "01" => Y <= A or Bout;
      when "10" => Y <= S;
      when "11" => Y <=
        ("00000000000000000000000000000000" & S(31));
      when others => Y <= X"00000000";
    end case;
  end process;
end;
```

```
library IEEE;
use IEEE.STD_LOGIC_1164.all;
use ieee.std_logic_unsigned.all;

entity signext is
  port(A:      in  STD_LOGIC_VECTOR(15 downto 0);
        Y:      out STD_LOGIC_VECTOR(31 downto 0));
end;
```

```
architecture synth of signext is
begin
  Y <= (15 downto 0 => a, others => a(15));
end;

library IEEE;
use IEEE.STD_LOGIC_1164.all;
use ieee.std_logic_unsigned.all;

entity zeroext is
  port(A:      in  STD_LOGIC_VECTOR(15 downto 0);
       Y:      out STD_LOGIC_VECTOR(31 downto 0));
end;
architecture synth of zeroext is
begin
  Y <= (15 downto 0 => a, others => '0');
end;

-- for lb / lbu
library IEEE;
use IEEE.STD_LOGIC_1164.all;
use ieee.std_logic_unsigned.all;

entity signext8_32 is
  port(A:      in  STD_LOGIC_VECTOR(7 downto 0);
       Y:      out STD_LOGIC_VECTOR(31 downto 0));
end;
architecture synth of signext8_32 is
begin
  Y <= (7 downto 0 => a, others => a(7));
end;

-- for lb / lbu
library IEEE;
use IEEE.STD_LOGIC_1164.all;
use ieee.std_logic_unsigned.all;

entity zeroext8_32 is
  port(A:      in  STD_LOGIC_VECTOR(7 downto 0);
       Y:      out STD_LOGIC_VECTOR(31 downto 0));
end;
architecture synth of zeroext8_32 is
begin
  Y <= (7 downto 0 => a, others => '0');
end;
```

Exercise 7.29

\$s0 is written, \$t4 and \$t5 are read in cycle 5.

Exercise 7.31

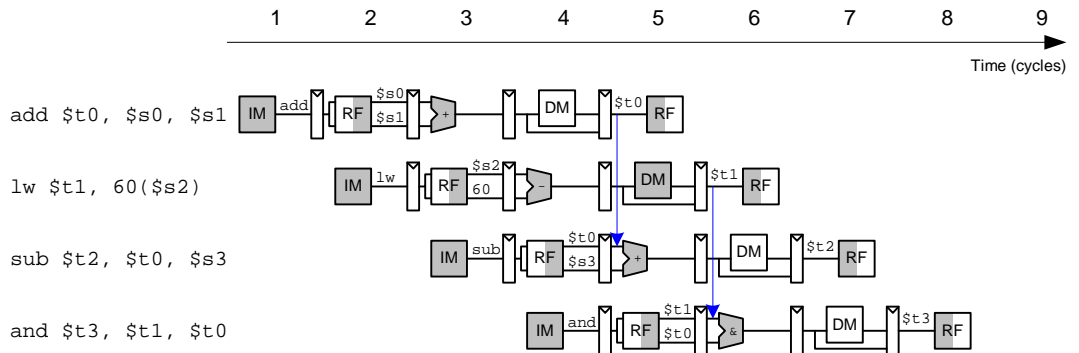

FIGURE 7.9 Abstract pipeline for Exercise 7.31

Exercise 7.33

It takes $3 + 6(10) + 3 = \mathbf{66}$ clock cycles to issue all the instructions.

instructions = $3 + 5(10) + 2 = 55$

CPI = $66 \text{ clock cycles} / 55 \text{ instructions} = \mathbf{1.2}$.

Exercise 7.35

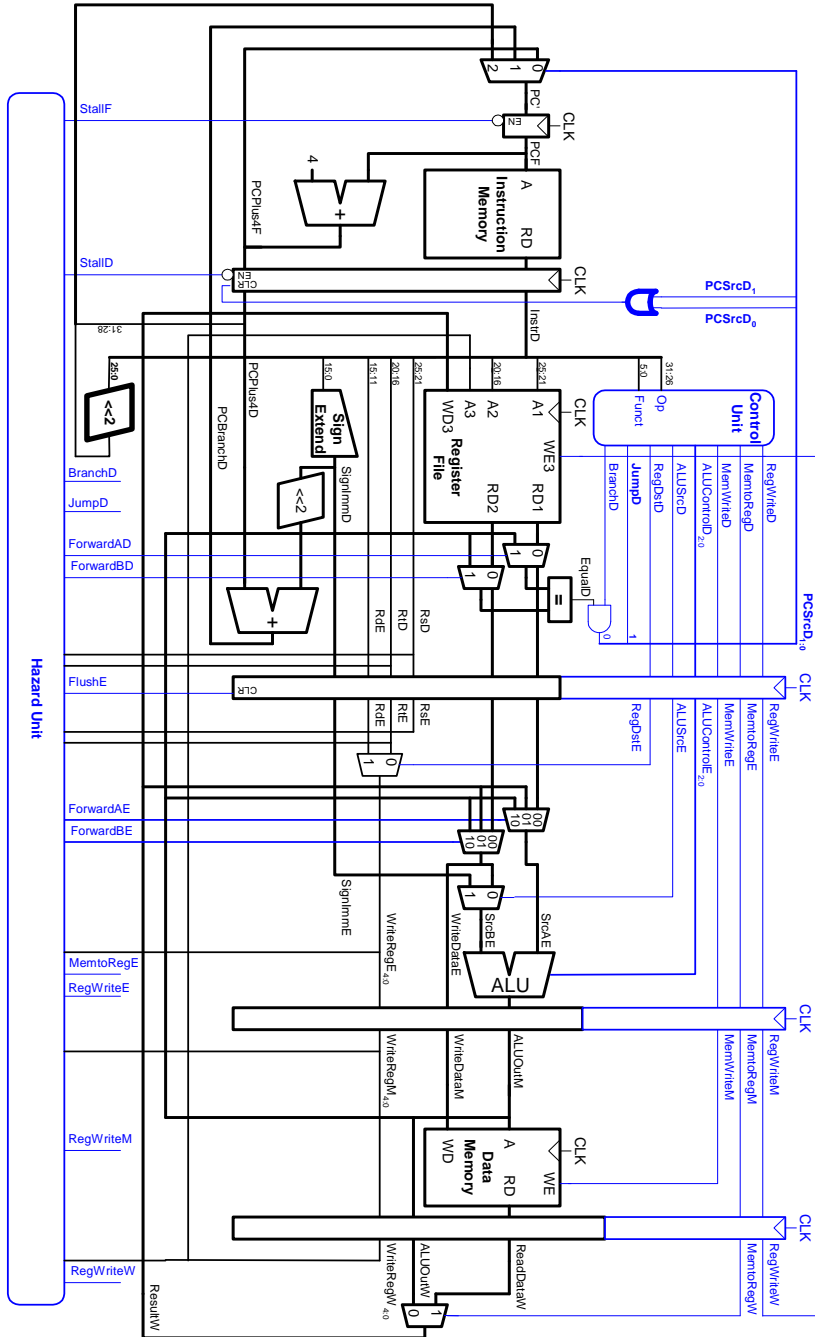

Instruction	opcode	RegWrite	RegDst	ALUSrc	Branch	MemWrite	MemtoReg	ALUOp	JumpD
R-type	000000	1	1	0	0	0	0	10	0
lw	100011	1	0	1	0	0	1	00	0
sw	101011	0	X	1	0	1	X	00	0
beq	000100	0	X	0	1	0	X	01	0
j	000010	0	X	X	0	0	X	XX	1

TABLE 7.12 Main decoder truth table enhanced to support j

We must also write new equations for the flush signal, *FlushE*.

$$\text{FlushE} = \text{lwstall} \text{ OR } \text{branchstall} \text{ OR } \text{JumpD}$$

Exercise 7.37

The critical path is the Decode stage, according to Equation 7.5:

$T_{c3} = \max(30 + 250 + 20, 2(150 + 25 + 40 + 15 + 25 + 20), 30 + 25 + 25 + 200 + 20, 30 + 220 + 20, 2(30 + 25 + 100)) = \max(300, 550, 300, 270, 310) = 550$ ps. The next slowest stage is 310 ps for the writeback stage, so it doesn't make sense to make the Decode stage any faster than that.

The slowest unit in the Decode stage is the register file read (150 ps). We need to reduce the cycle time by $550 - 310 = 240$ ps. Thus, we need to reduce the register file read delay by $240/2 = 120$ ps to $(150 - 120) = 30$ ps.

The new cycle time is **310 ps**.

Exercise 7.39

$$\text{CPI} = 0.25(1+0.5*6) + 0.1(1) + 0.11(1+0.3*1)+0.02(2)+0.52(1) = 1.8$$

$$\text{Execution Time} = (100 \times 10^9 \text{ instructions})(1.8 \text{ cycles/instruction})(400 \times 10^{-12} \text{ s/cycle}) = 72\text{s}$$

Exercise 7.41

MIPS Pipelined Processor Hazard Unit

SystemVerilog

```

module hazard(input logic [4:0] rsD, rtD, rsE, rtE,
             input logic [4:0] writeregE,
                    writeregM, writeregW,
             input logic regwriteE, regwriteM,
                    regwriteW,
             input logic memtoeregE, memtoeregM,
             input logic branchD,
             output logic forwardaD, forwardbD,
             output logic [1:0] forwardaE, forwardbE,
             output logic stallF, stallD,
                    flushE);

logic lwstallD, branchstallD;

// forwarding sources to D stage (branch equality)
assign forwardaD = (rsD != 0 & rsD == writeregM &
                    regwriteM);
assign forwardbD = (rtD != 0 & rtD == writeregM &
                    regwriteM);

// forwarding sources to E stage (ALU)
always_comb
begin
    forwardaE = 2'b00; forwardbE = 2'b00;
    if (rsE != 0)
        if (rsE == writeregM & regwriteM)
            forwardaE = 2'b10;
        else if (rsE == writeregW & regwriteW)
            forwardaE = 2'b01;
    if (rtE != 0)
        if (rtE == writeregM & regwriteM)
            forwardbE = 2'b10;
        else if (rtE == writeregW & regwriteW)
            forwardbE = 2'b01;
end

// stalls
assign #1 lwstallD = memtoeregE &
                    (rtE == rsD | rtE == rtD);
assign #1 branchstallD = branchD &
                    (regwriteE &
                     (writeregE == rsD | writeregE == rtD) |
                     memtoeregM &
                     (writeregM == rsD | writeregM == rtD));

assign #1 stallD = lwstallD | branchstallD;
assign #1 stallF = stallD;
// stalling D stalls all previous stages
assign #1 flushE = stallD;
// stalling D flushes next stage

// Note: not necessary to stall D stage on store
// if source comes from load;
// instead, another bypass network could
// be added from W to M
endmodule
    
```

VHDL

```

library IEEE; use IEEE.STD_LOGIC_1164.all;
entity hazard is -- hazard unit
    port(rsD, rtD, rsE, rtE:          in  STD_LOGIC_VECTOR(4 downto 0);
          writeregE, writeregM, writeregW: in  STD_LOGIC_VECTOR(4 downto 0);
          regwriteE, regwriteM, regwriteW: in  STD_LOGIC;
          memtoeregE, memtoeregM, branchD: in  STD_LOGIC;
          forwardaD, forwardbD:         out STD_LOGIC;
          forwardaE, forwardbE:         out STD_LOGIC_VECTOR(1 downto 0);
          stallF, flushE:               out STD_LOGIC;
          stallD:                       inout STD_LOGIC);
end;

architecture behave of hazard is
    signal lwstallD, branchstallD: STD_LOGIC;
begin
    -- forwarding sources to D stage (branch equality)
    forwardaD <= '1' when ((rsD /= "00000") and (rsD = writeregM) and
                          (regwriteM = '1'))
                else '0';
    forwardbD <= '1' when ((rtD /= "00000") and (rtD = writeregM) and
                          (regwriteM = '1'))
                else '0';

    -- forwarding sources to E stage (ALU)
    process(all) begin
        forwardaE <= "00"; forwardbE <= "00";
        if (rsE /= "00000") then
            if ((rsE = writeregM) and (regwriteM = '1')) then
                forwardaE <= "10";
            elsif ((rsE = writeregW) and (regwriteW = '1')) then
                forwardaE <= "01";
            end if;
        end if;
        if (rtE /= "00000") then
            if ((rtE = writeregM) and (regwriteM = '1')) then
                forwardbE <= "10";
            elsif ((rtE = writeregW) and (regwriteW = '1')) then
                forwardbE <= "01";
            end if;
        end if;
    end process;

    -- stalls
    lwstallD <= '1' when ((memtoeregE = '1') and ((rtE = rsD) or (rtE = rtD)))
                else '0';
    branchstallD <= '1' when ((branchD = '1') and
                            (((regwriteE = '1') and
                              ((writeregE = rsD) or (writeregE = rtD))) or
                             ((memtoeregM = '1') and
                              ((writeregM = rsD) or (writeregM = rtD)))))
                            else '0';
    stallD <= (lwstallD or branchstallD) after 1 ns;
    stallF <= stallD after 1 ns; -- stalling D stalls all previous stages
    flushE <= stallD after 1 ns; -- stalling D flushes next stage

    -- not necessary to stall D stage on store if source comes from load;
    -- instead, another bypass network could be added from W to M
end;
    
```

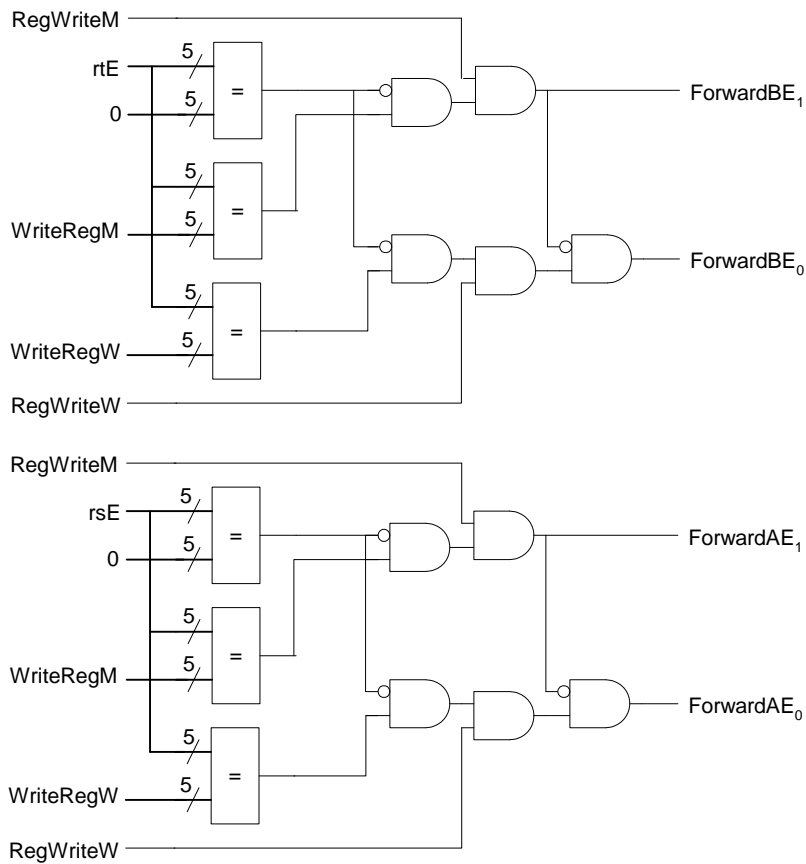

FIGURE 7.10 Hazard unit hardware for forwarding to the Execution stage

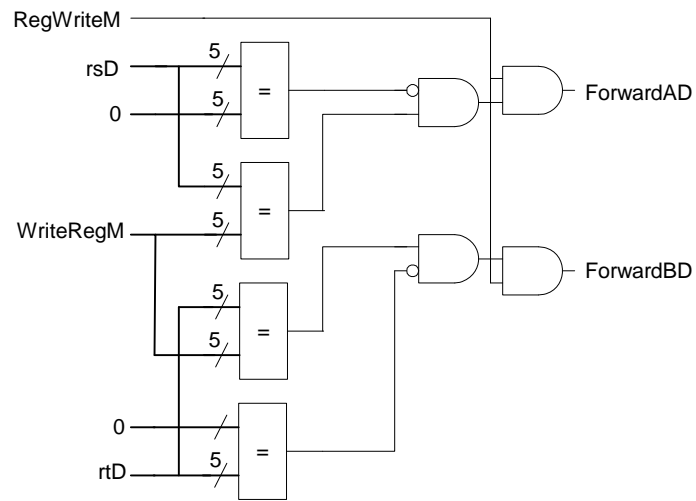

FIGURE 7.11 Hazard unit hardware for forwarding to the Decode stage

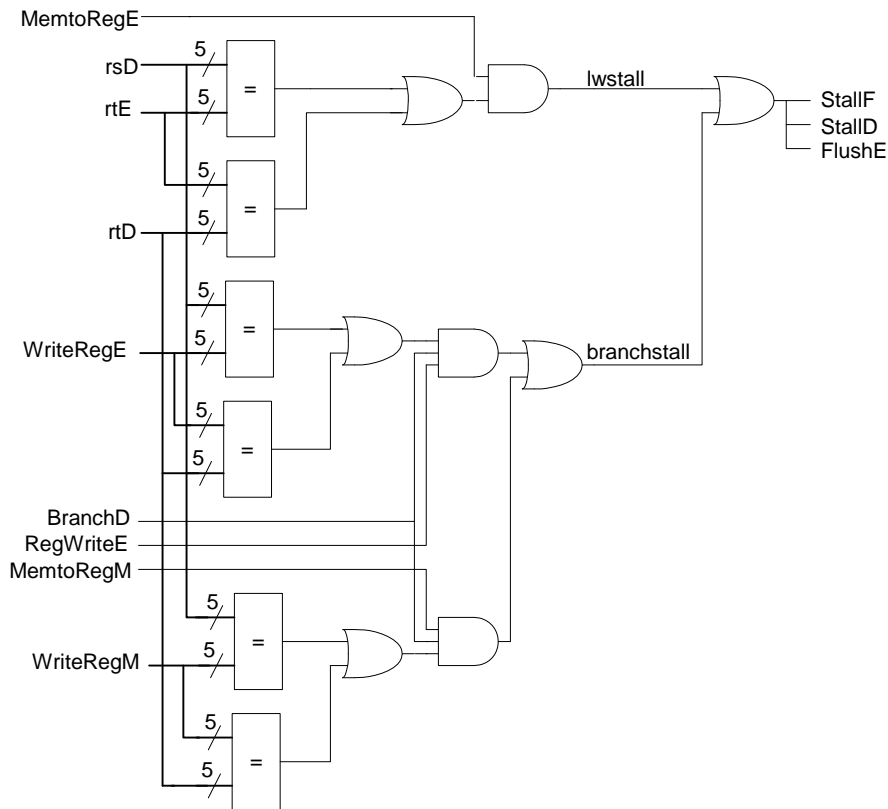

FIGURE 7.12 Hazard unit hardware for stalling/flushing in the Fetch, Decode, and Execute stages

Question 7.1

A pipelined microprocessors with N stages offers an ideal speedup of N over nonpipelined microprocessor. This speedup comes at the cost of little extra hardware: pipeline registers and possibly a hazard unit.

Question 7.3

A hazard in a pipelined microprocessor occurs when the execution of an instruction depends on the result of a previously issued instruction that has not completed executing. Some options for dealing with hazards are: (1) to have the compiler insert nops to prevent dependencies, (2) to have the compiler reorder the code to eliminate dependencies (inserting nops when this is impossible), (3) to have the hardware stall (or flush the pipeline) when there is a dependency, (4)

to have the hardware forward results to earlier stages in the pipeline or stall when that is impossible.

Options (1 and 2): Advantages of the first two methods are that no added hardware is required, so area and, thus, cost and power is minimized. However, performance is not maximized in cases where nops are inserted.

Option 3: The advantage of having the hardware flush or stall the pipeline as needed is that the compiler can be simpler and, thus, likely faster to run and develop. Also, because there is no forwarding hardware, the added hardware is minimal. However, again, performance is not maximized in cases where forwarding could have been used instead of stalling.

Option 4: This option offers the greatest performance advantage but also costs the most hardware for forwarding, stalling, and flushing the pipeline as necessary because of dependencies.

A combination of options 2 and 4 offers the greatest performance advantage at the cost of more hardware and a more sophisticated compiler.

CHAPTER 8

Exercise 8.1

Answers to this question will vary.

Temporal locality: (1) making phone calls (if you called someone recently, you're likely to call them again soon). (2) using a textbook (if you used a textbook recently, you will likely use it again soon).

Spatial locality: (1) reading a magazine (if you looked at one page of the magazine, you're likely to look at next page soon). (2) walking to locations on campus - if a student is visiting a professor in the engineering department, she or he is likely to visit another professor in the engineering department soon.

Exercise 8.3

Repeat data accesses to the following addresses:
0x0 0x10 0x20 0x30 0x40

The miss rate for the fully associative cache is: 100%. Miss rate for direct-mapped cache is $2/5 = 40\%$.

Exercise 8.5

(a) Increasing block size will increase the cache's ability to take advantage of spatial locality. This will reduce the miss rate for applications with spatial locality. However, it also decreases the number of locations to map an address, possibly increasing conflict misses. Also, the miss penalty (the amount of time it takes to fetch the cache block from memory) increases.

(b) Increasing the associativity increases the amount of necessary hardware but in most cases decreases the miss rate. Associativities above 8 usually show only incremental decreases in miss rate.

(c) Increasing the cache size will decrease capacity misses and could decrease conflict misses. It could also, however, increase access time.

Exercise 8.7

(a) **False.**

Counterexample: A 2-word cache with block size of 1 and access pattern:
 0 4 8

has a 50% miss rate with a direct-mapped cache, and a 100% miss rate with a 2-way set associative cache.

(b) **True.**

The 16KB cache is a superset of the 8KB cache. (Note: it's possible that they have the *same* miss rate.)

(c) **Usually true.**

Instruction memory accesses display great spatial locality, so a large block size reduces the miss rate.

Exercise 8.9

Figure 8.1 shows where each address maps for each cache configuration.

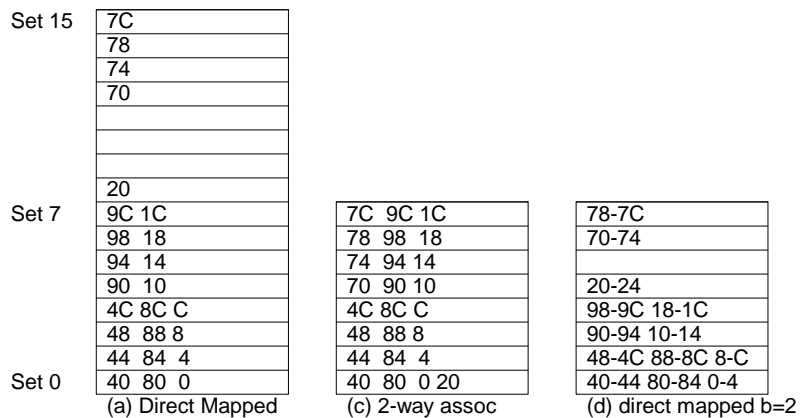

FIGURE 8.1 Address mappings for Exercise 8.9

(a) **80% miss rate.** Addresses 70-7C and 20 use unique cache blocks and are not removed once placed into the cache. Miss rate is $20/25 = 80\%$.

(b) **100% miss rate.** A repeated sequence of length greater than the cache size produces no hits for a fully-associative cache using LRU.

(c) **100% miss rate.** The repeated sequence makes at least three accesses to each set during each pass. Using LRU replacement, each value must be replaced each pass through.

(d) **40% miss rate.** Data words from consecutive locations are stored in each cache block. The larger block size is advantageous since accesses in the given sequence are made primarily to consecutive word addresses. A block size of two cuts the number of block fetches in half since two words are obtained per block fetch. The address of the second word in the block will always hit in this type of scheme (e.g. address 44 of the 40-44 address pair). Thus, the second consecutive word accesses always hit: 44, 4C, 74, 7C, 84, 8C, 94, 9C, 4, C, 14, 1C. Tracing block accesses (see Figure 8.1) shows that three of the eight blocks (70-74, 78-7C, 20-24) also remain in memory. Thus, the hit rate is: $15/25 = 60\%$ and miss rate is 40%.

Exercise 8.11

- (a) 128
- (b) 100%
- (c) ii

Exercise 8.13

- (a)

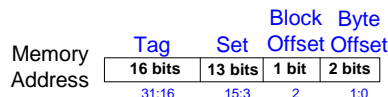

(b) Each tag is 16 bits. There are $32\text{Kwords} / (2 \text{ words / block}) = 16\text{K}$ blocks and each block needs a tag: $16 \times 16\text{K} = 2^{18} = 256 \text{ Kbits}$ of tags.

(c) Each cache block requires: 2 status bits, 16 bits of tag, and 64 data bits, thus each set is $2 \times 82 \text{ bits} = \mathbf{164 \text{ bits}}$.

(d) The design must use enough RAM chips to handle both the total capacity and the number of bits that must be read on each cycle. For the data, the SRAM must provide a capacity of 128 KB and must read 64 bits per cycle (one 32-bit word from each way). Thus the design needs at least $128\text{KB} / (8\text{KB}/\text{RAM}) = 16 \text{ RAMs}$ to hold the data and $64 \text{ bits} / (4 \text{ pins}/\text{RAM}) = 16 \text{ RAMs}$ to supply the number of bits. These are equal, so the design needs exactly 16 RAMs for the data.

For the tags, the total capacity is 32 KB, from which 32 bits (two 16-bit tags) must be read each cycle. Therefore, only 4 RAMs are necessary to meet the capacity, but 8 RAMs are needed to supply 32 bits per cycle. Therefore, the design will need 8 RAMs, each of which is being used at half capacity.

With 8Ksets, the status bits require another $8\text{K} \times 4\text{-bit RAM}$. We use a $16\text{K} \times 4\text{-bit RAM}$, using only half of the entries.

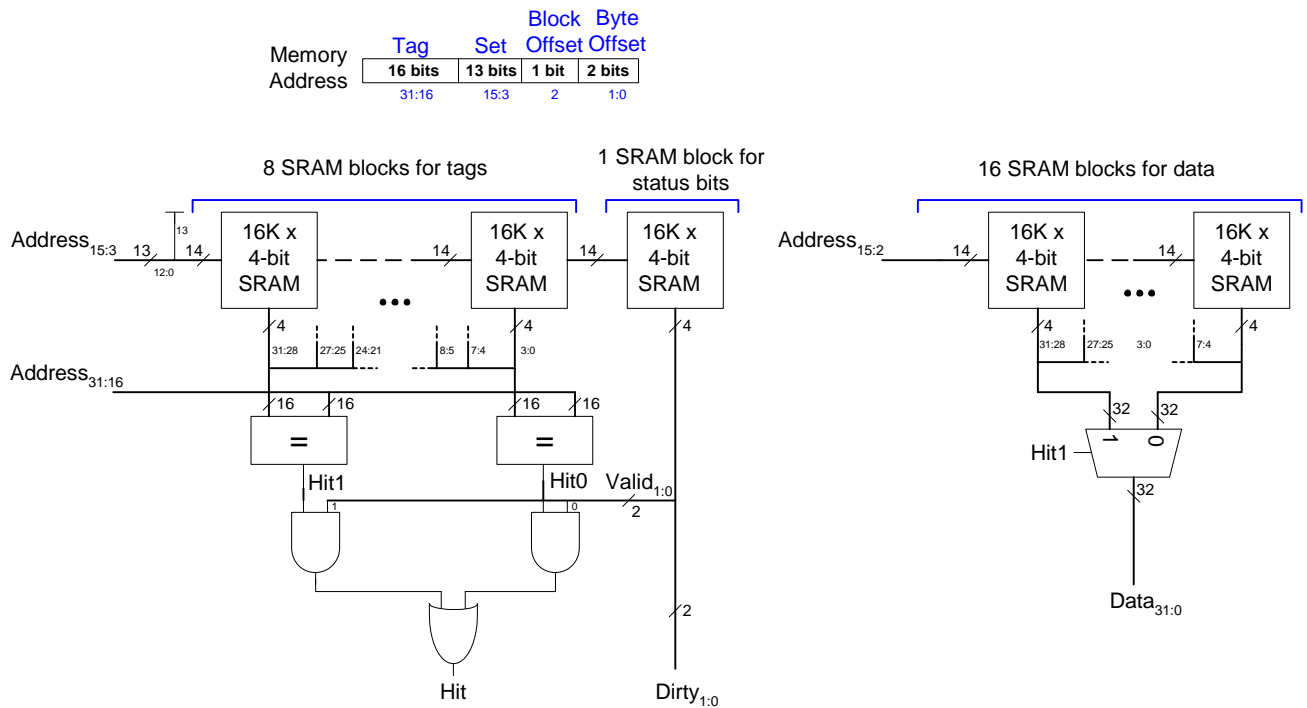

FIGURE 8.2 Cache design for Exercise 8.13

Bits 15:2 of the address select the word within a set and block. Bits 15-3 select the set. Bits 31:16 of the address are matched against the tags to find a hit in one (or none) of the two blocks with each set.

Exercise 8.15

(a)

FIFO:

FIFO replacement approximates LRU replacement by discarding data that has been in the cache longest (and is thus least likely to be used again). A FIFO cache can be stored as a queue, so the cache need not keep track of the least recently used way in an N -way set-associative cache. It simply loads a new cache block into the next way upon a new access. FIFO replacement doesn't work well when the *least recently used* data is not also the data fetched *longest ago*.

Random:

Random replacement requires less overhead (storage and hardware to update status bits). However, a random replacement policy might randomly evict recently used data. In practice random replacement works quite well.

(b)

FIFO replacement would work well for an application that accesses a first set of data, then the second set, then the first set again. It then accesses a third set of data and finally goes back to access the second set of data. In this case, FIFO would replace the first set with the third set, but LRU would replace the second set. The LRU replacement would require the cache to pull in the second set of data twice.

Exercise 8.17

(a)

$$AMAT = t_{\text{cache}} + MR_{\text{cache}} t_{\text{MM}}$$

With a cycle time of $1/1 \text{ GHz} = 1 \text{ ns}$,

$$AMAT = 1 \text{ ns} + 0.15(200 \text{ ns}) = 31 \text{ ns}$$

(b) $\text{CPI} = 31 + 4 = 35$ cycles (for a load)

$\text{CPI} = 31 + 3 = 34$ cycles (for a store)

(c) Average $\text{CPI} = (0.11 + 0.02)(3) + (0.52)(4) + (0.1)(34) + (0.25)(35) =$

14.6

(d) Average $\text{CPI} = 14.6 + 0.1(200) = 34.6$

Exercise 8.19

1 million gigabytes of hard disk $\approx 2^{20} \times 2^{30} = 2^{50}$ bytes = 1 petabytes

10,000 gigabytes of hard disk $\approx 2^{14} \times 2^{30} = 2^{44}$ bytes = 16 terabytes

Thus, the system would need **44 bits** for the physical address and **50 bits** for the virtual address.

Exercise 8.21

(a) **31 bits**

(b) $2^{50}/2^{12} = 2^{38}$ virtual pages

(c) $2 \text{ GB} / 4 \text{ KB} = 2^{31}/2^{12} = 2^{19}$ physical pages

(d) virtual page number: **38 bits**; physical page number = **19 bits**

(e) 2^{38} page table entries (one for each virtual page).

(f) Each entry uses 19 bits of physical page number and 2 bits of status information. Thus, **3 bytes** are needed for each entry (rounding 21 bits up to the nearest number of bytes).

(h) The total table size is **3×2^{38} bytes**.

Exercise 8.23

(a) $1 \text{ valid bit} + 19 \text{ data bits (PPN)} + 38 \text{ tag bits (VPN)} \times 128 \text{ entries} = 58 * 128 \text{ bits} = 7424 \text{ bits}$

(b)

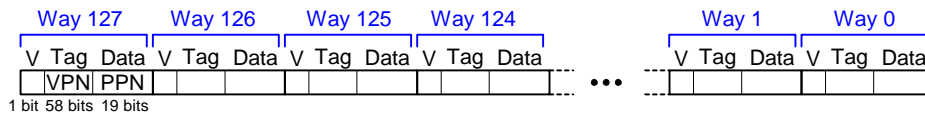

(c) 128 x 58-bit SRAM

Exercise 8.25

(a) Each entry in the page table has 2 status bits (*V* and *D*), and a physical page number ($22 - 16 = 6$ bits). The page table has $2^{25 - 16} = 2^9$ entries.

Thus, the total page table size is $2^9 \times 8 \text{ bits} = \mathbf{4096 \text{ bits}}$

(b)

This would increase the virtual page number to $25 - 14 = 11$ bits, and the physical page number to $22 - 14 = 8$ bits. This would increase the page table size to:

$2^{11} \times 10 \text{ bits} = \mathbf{20480 \text{ bits}}$

This increases the page table by 5 times, wasted valuable hardware to store the extra page table bits.

(c)

Yes, this is possible. In order for concurrent access to take place, the number of set + block offset + byte offset bits must be less than the page offset bits.

(d) It is impossible to perform the tag comparison in the on-chip cache concurrently with the page table access because the upper (most significant) bits of the physical address are unknown until after the page table lookup (address translation) completes.

Exercise 8.27

(a) 2^{32} bytes = 4 gigabytes

(b) The amount of the hard disk devoted to virtual memory determines how many applications can run and how much virtual memory can be devoted to each application.

(c) The amount of physical memory affects how many physical pages can be accessed at once. With a small main memory, if many applications run at once or a single application accesses addresses from many different pages, thrashing can occur. This can make the applications dreadfully slow.

Exercise 8.29

(a)

```
# MIPS code for Traffic Light FSM
    addi $t0, $0, 0xC    # $t0 = green / red
    addi $t1, $0, 0x14   # $t1 = yellow / red
    addi $t2, $0, 0x21   # $t2 = red / green
    addi $t3, $0, 0x22   # $t3 = red / yellow

Start: sw    $t2, 0xF004($0) # lights = red / green
S0:    lw    $t4, 0xF000($0) # $t4 = sensor values
        andi $t4, $t4, 0x2   # $t4 = TA
        bne $t4, $0, S0     # if TA == 1, loop back to S0

S1:    sw    $t3, 0xF004($0) # lights = red / yellow
        sw    $t0, 0xF004($0) # lights = green / red
S2:    lw    $t4, 0xF000($0) # $t4 = sensor values
        andi $t4, $t4, 0x1   # $t4 = TB
        bne $t4, $0, S2     # if TB == 1, loop back to S2

S3:    sw    $t1, 0xF004($0) # lights = yellow / red
        j    Start
```

(b)

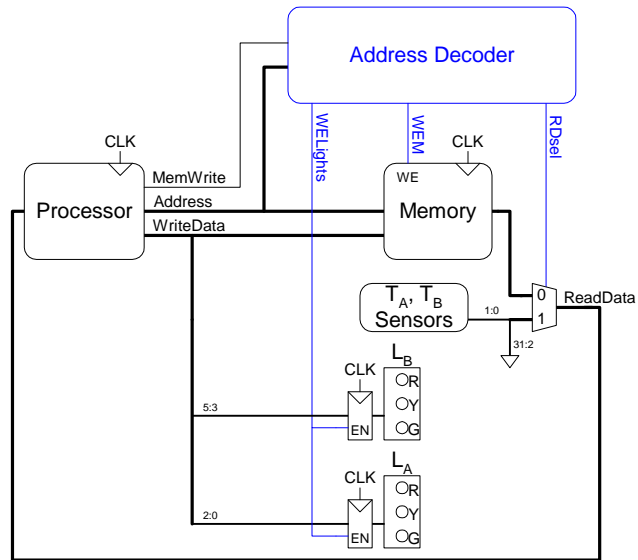

(c) **Address Decoder for Exercise 8.29****SystemVerilog**

```

module addrdec(input  logic [31:0] addr,
              input  logic      memwrite,
              output logic      WELights, Mwrite,
              output logic      rdselect);

    parameter T      = 16'hF000; // traffic sensors
    parameter Lights = 16'hF004; // traffic lights

    logic [15:0] addressbits;

    assign addressbits = addr[15:0];

    always_comb
    if (addr[31:16] == 16'hFFFF) begin
        // writedata control
        if (memwrite)
            if (addressbits == Lights)
                {WELights, Mwrite, rdselect} = 3'b100;
            else
                {WELights, Mwrite, rdselect} = 3'b010;

        // readdata control
        else
            if ( addressbits == T )
                {WELights, Mwrite, rdselect} = 3'b001;
            else
                {WELights, Mwrite, rdselect} = 3'b000;
        end
    else
        {WELights, Mwrite, rdselect} =
        {1'b0, memwrite, 1'b0};
    endmodule

```

VHDL

```

library IEEE; use IEEE.STD_LOGIC_1164.all;
entity addrdec is -- address decoder
    port(addr:          in STD_LOGIC_VECTOR(31 downto 0);
          memwrite:     in STD_LOGIC;
          WELights, Mwrite, rdselect: out STD_LOGIC);
end;

architecture struct of addrdec is
begin

    process(all) begin
        if (addr(31 downto 16) = X"FFFF") then
            -- writedata control
            if (memwrite = '1') then
                if (addr(15 downto 0) = X"F004") then -- traffic lights
                    WELights <= '1'; Mwrite <= '0'; rdselect <= '0';
                else
                    WELights <= '0'; Mwrite <= '1'; rdselect <= '0';
                end if;
            -- readdata control
            else
                if ( addr(15 downto 0) = X"F000" ) then -- traffic sensors
                    WELights <= '0'; Mwrite <= '0'; rdselect <= '1';
                else
                    WELights <= '0'; Mwrite <= '0'; rdselect <= '0';
                end if;
            end if;

            -- not a memory-mapped address
        else
            WELights <= '0'; Mwrite <= memwrite; rdselect <= '0';
        end if;
    end process;
end;

```

Question 8.1

Caches are categorized based on the number of blocks (B) in a set. In a direct mapped cache, each set contains exactly one block, so the cache has $S = B$ sets. Thus a particular main memory address maps to a unique block in the cache. In an N -way set associative cache, each set contains N blocks. The address still maps to a unique set, with $S = B / N$ sets. But the data from that address can go in any of the N blocks in the set. A fully associative cache has only $S = 1$ set. Data can go in any of the B blocks in the set. Hence, a fully associative cache is another name for a B -way set associative cache.

A **direct mapped cache** performs better than the other two when the data access pattern is to sequential cache blocks in memory with a repeat length one greater than the number of blocks in the cache.

An **N -way set-associative cache** performs better than the other two when N sequential block accesses map to the same set in the set-associative *and* di-

direct-mapped caches. The last set has $N+1$ blocks that map to it. This access pattern then repeats.

In the direct-mapped cache, the accesses to the same set conflict, causing a 100% miss rate. But in the set-associative cache all accesses (except the last one) don't conflict. Because the number of block accesses in the repeated pattern is one more than the number of blocks in the cache, the fully associative cache also has a 100% miss rate.

A **fully associative cache** performs better than the other two when the direct-mapped and set-associative accesses conflict and the fully associative accesses don't. Thus, the repeated pattern must access at most B blocks that map to conflicting sets in the direct and set-associative caches.

Question 8.3

The advantages of using a virtual memory system are the illusion of a larger memory without the expense of expanding the physical memory, easy relocation of programs and data, and protection between concurrently running processes.

The disadvantages are a more complex memory system and the sacrifice of some physical and possibly virtual memory to store the page table.

Question 8.5

No, addresses used for memory-mapped I/O may not be cached. Otherwise, repeated reads to the I/O device would read the old (cached) value. Likewise, repeated writes would write to the cache instead of the I/O device.